



OPERATION MANUAL

EN | Original

MU-C; MU-C Hydro

EX MACHINE No 2015

EDITION 11.2022

REFERENCE NUMBER MU-C-F-HY_BA_15_EN_2022-11

Machine identification

In order for your dealer to assist you as efficiently as possible, you will need to provide some information about your machine. Please enter the information here.

Designation

Working width

Weight

Machine number

Additional equipment

Dealer's address

Manufacturer's address

Müthing GmbH & Co. KG Soest
Am Silberg 23
59494 Soest
Germany

Handover declaration

- Fill out this sheet with your dealer.
- Then separate this sheet from the operating manual and send it to the manufacturer within 10 days of delivery. Only in this way will the guarantee be effective from the date of delivery

To
Müthing GmbH & Co. KG
Am Silberberg 23
59494 Soest
Germany

I have bought the machine described below from Müthing GmbH & Co. KG Soest, and confirm full delivery and handover of the machine including the operating manual and spare parts list, as well as training in operating the devices with safety instructions and warning information from your dealer.

I confirm additionally that I have read and understood the operating manual and am in agreement with the information contained therein. This applies in particular to the chapter Safety.

Client

Name		First name	
Address			
Post code		Town/city	
Telephone		Fax	
E-mail		Date	

Machine

Machine	MU-	Serial number	
Working width		Gear-box	
Rigid mounting		Non-rigid mounting	
Year of construction		Delivery date	
Delivered by			

Signature of client

Signature and stamp of sales partner

Handover declaration

Handover declaration – Copy

– This sheet remains with the client in the operating manual

I have bought the machine described below from Mühling GmbH & Co. KG Soest, and confirm full delivery and handover of the machine including the operating manual and spare parts list, as well as training in operating the devices with safety instructions and warning information from your dealer.

I confirm additionally that I have read and understood the operating manual and am in agreement with the information contained therein. This applies in particular to the chapter Safety.

Client

Name		First name	
Address			
Post code		Town/city	
Telephone		Fax	
E-mail		Date	

Machine

Machine	MU-	Serial number	
Working width		Gear-box	
Rigid mounting		Non-rigid mounting	
Year of construction		Delivery date	
Delivered by			

Signature of client

Signature and stamp of sales partner

Table of Contents

Handover declaration	3	Parking and storage	42
Handover declaration – Copy	5	Setting down the machine in a secure position	42
About this operating manual	8	Storing the machine	43
Target group	8	Maintenance	44
Safety	8	For your safety	44
Instruction	8	General information	45
Other applicable documents	8	Maintenance intervals and setting work	48
Symbols	9	Lubricating work	49
Safety	10	PTO shaft	51
For your safety	10	Transmission oil	52
Warning signs	10	Tools	54
Definitions	13	V-belt	55
Who is allowed to operate the machine?	13	Runners	58
Coupling	14	Accessory	59
Centre of gravity	15	Wear insert	59
Road transport	17	short-chopping bar	59
Putting the machine into operation	17	Support wheels	59
Uncoupling the machine	19	Operating hours counter	59
Care and maintenance	19	Fault elimination	60
Further regulations	20	Disposal of the machine	62
Familiarising yourself with the machine .	21	EU-conformity declaration	63
Range of application of the machine	21	EC Directive	
Features of the machine	22	2006/42/EG	63
Designation of components	23	EC Directive	
Technical specifications	25	2006/42/EG	64
Delivery and assembly	28	UK Declaration of Conformity	65
Checking the scope of delivery	28	UKCA	65
Adapter MU-C	29	UKCA	66
Rigid implement triangles	29	Index	67
Attachment kits	29		
Swivelling implement triangles	30		
Adapter frame	30		
Coupling the machine	32		
Implement triangles	32		
Two-point connection	33		
Three point linkage	33		
Mechanical drive	34		
Hydraulic drive	35		
Preparation	36		
Working width	36		
Driving on the road	37		
Transport position	37		
Transport without coupling	37		
Mulching	38		
Task	38		
Cleaning and care	41		
Cleaning	41		
Care	41		

About this operating manual

Target group

This operating manual is intended for trained machine operators and persons who are otherwise qualified to carry out landscape work and who have received training in how to use this machine.

Safety

Familiarise yourself with the contents of this operating manual which are relevant for your activity before commissioning or assembling the machine. Always read through the safety instructions in the chapter "Safety" and observe the warning information in the individual chapters. In this way, you will achieve optimum work results and operational safety.

For the employer

Staff must be instructed in the safe handling of the machine before the initial commissioning. Untrained or unauthorised persons are not permitted to use the machine.

The following are included in this training:

- Checking that staff possess the necessary requirements for safely handling the machine.
- Handing out the operating manual and the other relevant and applicable documents or an intensive course of training which, in particular, includes the safe handling of the machine.

Regular instruction sessions

Instruct your staff regularly, but at least once a year, concerning the basic procedural measures for safely handling the machine.

Instruction

You will receive training from your dealership concerning using the controls, safe operation and care of the machine. Commissioning without first receiving training is not permitted.

Other applicable documents

In addition to the operating manual, other documents also form an integral part of the machine:

EU-conformity declaration	Integral part of this operating manual → Chapter »EU-conformity declaration«, Page 63
Spare parts list	Integral part of the delivery with this machine
PTO shaft operating manual	Integral part of the delivery with this machine

About this operating manual

Symbols

In order to make this manual clear and easy to read, we have used various symbols. They are explained below:

- A bullet point accompanies each item in a list
- ▶ A triangle indicates operating functions which must be performed
- An arrow indicates a cross-reference to other sections of this manual
- [+] A plus sign indicates an accessory that is not included in the standard version.

Pictograms

We have also used pictograms to help you find instructions more quickly:



The warning triangle indicates warning information. Failure to observe these safety instructions can result in:

- Moderate to serious injury
- Fatal injury

You will find the warning information associated with individual operations, where it is important to observe the warning information before these operations are carried out.

You will also find safety instructions in the chapter »Safety« which cannot be assigned to any particular operations, but increase your ability to work safely in different situations.



This sign indicates important instructions regarding the machine. Failure to observe these safety instructions can result in:

- Serious faults in the correct operation of the machine.
- Damage to the machine



This symbol indicates information, tips and instructions about operation.



This symbol indicates tips for assembly or adjustment work.



This symbol indicates examples that help you to understand the instructions better.

Parts in the text which refer to individual machines or to conditions have a colored background. After the colored section, the text then applies again to all machines. For example:

Only for MU-Farmer/S with pneumatic brake system

- ▶ Connect brake hoses
- ▶ Connect hydraulic hoses

Safety

For your safety

This chapter contains general safety instructions. Each chapter of the operating manual contains additional warning instructions which are not described here. Observe the safety instructions:

- In the interest of your own safety,
- In the interest of the safety of others
- To ensure the safety of the machine

Numerous risks can result from handling landscaping machines the wrong way. Therefore, always work with particular care and never under time pressure. Therefore, always work with particular care and never under time pressure.

For the employer

Inform personnel working with the machine of these safety instructions at regular intervals and according to statutory regulations.

Warning signs

On the machine you will find labels that serve to ensure your safety. The labels must not be removed. If labels become illegible or begin to peel off, new labels can be ordered and attached in the appropriate places.

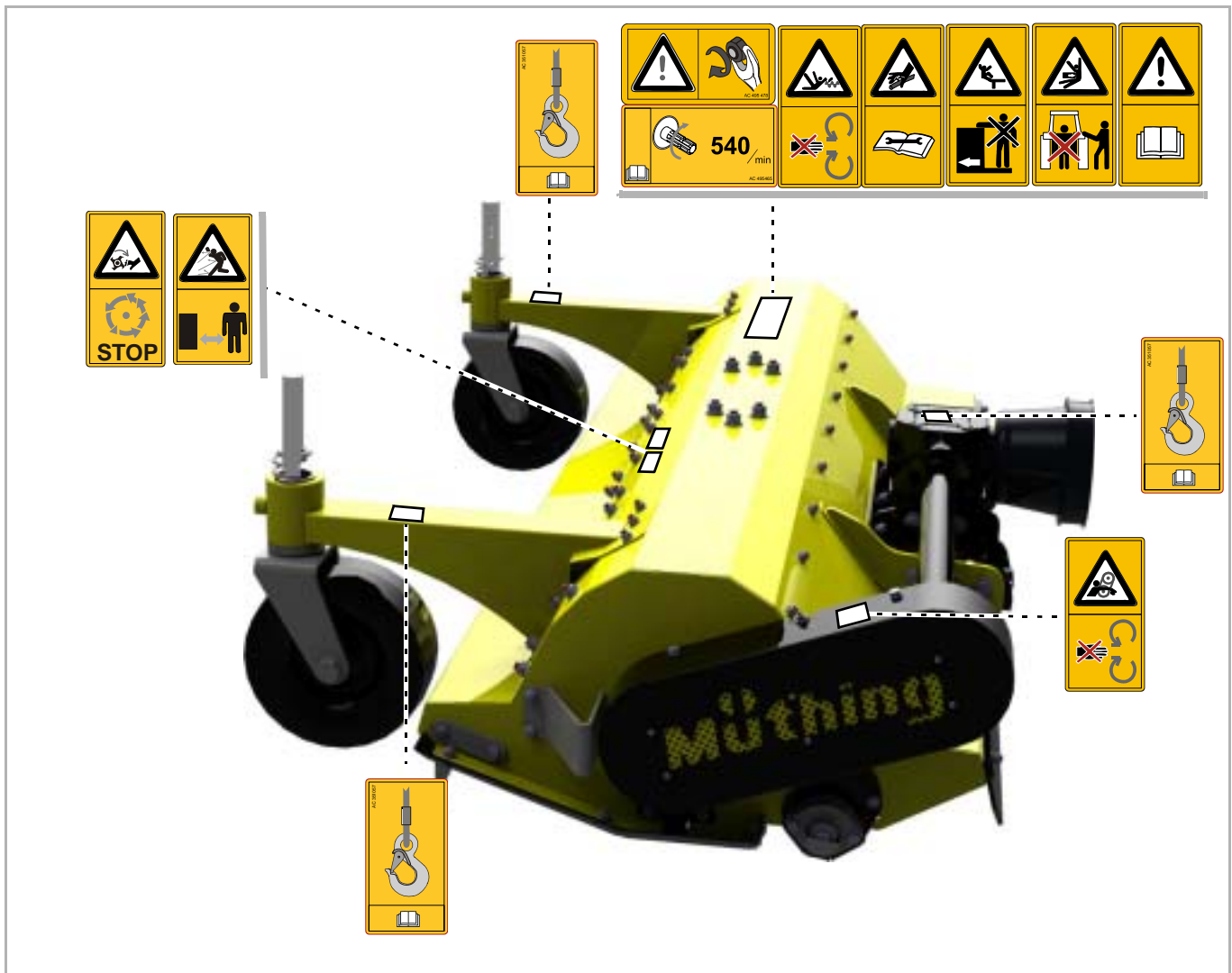

Meaning of warning signs



Read the operating manual carefully and follow the instructions
Commissioning of the machine must not take place before the operating manual has been read and understood. This particularly applies to safety instructions.



Do not stand between the carrier vehicle and the machine
Standing between the carrier vehicle and the machine while the engine is running is prohibited, especially during coupling and uncoupling. The carrier vehicle must also be secured so that it cannot roll away.



Riding on the machine is prohibited
It can result in serious or even fatal injury.



Do not remove protective devices
Do not open or remove the protective devices while the engine of the carrier vehicle is running. Never operate the machine without the protective device.



Be aware of the danger of being pulled in
There is a danger of being pulled into the PTO shaft in the event of inappropriate use.



Shackles
Only raise the machine using loading equipment at the points indicated.



Rotating and trailing machine parts

Only approach the machine when all machine parts have stopped moving.



Danger of objects being thrown out

During operation, there is a danger of objects such as stones being picked up and thrown out by the machine. Ensure that no persons are present in the hazard area.



Danger from moving machine parts

Nobody is permitted to remain within the hazard area during operation.



Do not stand in the slewing range

There is an extreme risk of injury within the slewing range from slewing or folding machine parts.

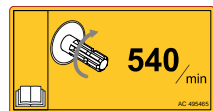

Check the rotational speed of the PTO stub shaft

Connect PTO shaft to a PTO stub shaft with an appropriate rpm. Always switch off the PTO stub shaft when working on the machine.



Retighten screws

After the first hours of operation, and as required, all screws must be checked and tightened if necessary. Vibrations might have loosened the screwed connections.

Definitions

All direction information is given in relation to the direction of travel of the machine:

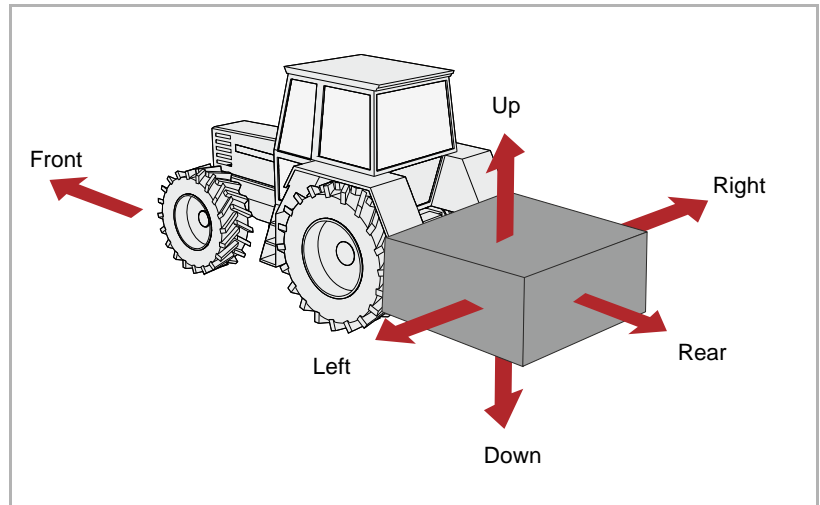

Who is allowed to operate the machine?

Only qualified personnel

Only qualified persons who have been informed of the dangers associated with handling the machine are permitted to operate, service or repair the machine. As a rule, such persons are trained machine operators or have had similar intensive training.

Coupling

Increased risk of injury

There is an increased risk of injury when the machine is being coupled to the carrier vehicle. Therefore:

- The carrier vehicle must be fitted with the corresponding adaptor in order to be coupled to the machine.
- Only couple the machine with the road chassis raised
- Secure the carrier vehicle so that it cannot roll away.
- Never stand between the carrier vehicle and the machine during coupling.
- Actuate the power lever slowly and carefully.

Failure to observe these instructions can result in serious or fatal injury.

Connect electric wires or cables only after mounting the attachment

The electrical supply to the carrier vehicle must not be connected up during the fitting of the lighting equipment. Short circuits and damage to the electronics are possible.

Only connect hydraulics at zero pressure

Only connect the hydraulic hoses to the carrier vehicle while the hydraulic system on the carrier vehicle and machine is de-pressurised. A hydraulic system under pressure can trigger unpredictable machine movements.

High pressures in the hydraulic system

The hydraulic system is under high pressure. Regularly check all lines, tubes and screwed connections for leaks and externally visible damage. Only use suitable tools when looking for leaks. Rectify any damage immediately. Oil escaping under pressure may result in injuries and fires. In the event of injuries, seek medical attention immediately.

Color-coded hydraulic hoses

To avoid operating errors, the sockets and plugs of the hydraulic connections between the carrier vehicle and the machine should be color-coded. Wrongly connected hydraulic hoses can trigger unpredictable movements of the machine.

Centre of gravity

Observe the total weight, axle loads, tyre load-bearing capacity and minimum ballast specifications

The front or rear mounting of machines must not cause the carrier vehicle's permissible total weight, permissible axle loads, or tyre load-bearing capacity to be exceeded. The front axle must bear at least 20 % of the empty weight of the carrier vehicle to ensure steering capability.

You can calculate:

- Total weight
- Axle loads
- Minimum added weight

Data

For this calculation, some data is required out of the following documents and measurement results:

- Operating manual of carrier vehicle
- This operating manual
- Measurement results from carrier vehicle and attached machine

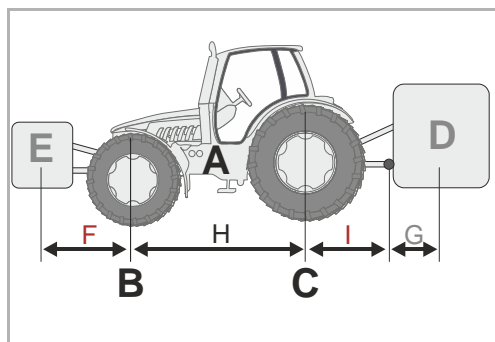

Data from the operating manual of the carrier vehicle:

- (A) unladen weight
- (B) front axle load
- (C) rear axle load
- (H) wheel base of carrier vehicle

Please take into consideration, for example, the weight of water in the tyres, accessories, etc.

Data from this operating manual:

- (D) Total weight of the machine when rear-mounted; the supporting load with the machines attached
- (E) Total weight of the machine when front-mounted
- (G) Distance between the lower link ball midpoint and the machine's centre of gravity when rear-mounted. With machines attached, $G=0$.

Data which you can determine by measuring:

- (F) Distance between the machine's centre of gravity when front-mounted and the front-axle midpoint
- (I) distance between the rear axle midpoint and the lower link ball midpoint. For rear-mounted machines between rear axle midpoint to drawbar coupling midpoint or hitch ball

Safety

Calculation

The measured values can now be inserted into the formulas.

Ballast with front weights

Calculating the **ballast with front weights** on rear-mounted machines.

$$\text{Front ballast in kg} = \frac{D \times (I + G) - (B \times H) + (0,2 \times A \times H)}{F + H}$$

Ballast with rear weights

Calculating the **ballast with rear weights** on front-mounted machines.

$$\text{Rear ballast in kg} = \frac{(E \times F) - (C \times H) + (0,45 \times A \times H)}{H + I + G}$$

Front axle load

Calculating the **actual front axle load**

$$\text{Front axle load in kg} = \frac{E \times (F + H) + (B \times H) - D \times (I + G)}{H}$$

Total weight

Calculating the **actual total weight**

$$\text{Total weight} = E + A + D$$

Rear axle load

Calculating the **actual rear axle load**

$$\text{Rear axle load in kg} = \text{actual total weight} - \text{actual front axle load}$$

Tyre load-bearing capacity

Data on the tyre load-bearing capacity of the front and rear tyres can be found in the tyre manufacturer's documentation.

- The front tyre load-bearing capacity for two wheels is equal to twice the permissible tyre load-bearing capacity of a single front wheel.
- The rear tyre load-bearing capacity for two wheels is equal to twice the permissible tyre load-bearing capacity of a single rear wheel.

Summary

Check if the following conditions are met:

- The actual rear axle load is less than the permissible values for the axle load stated in the operating manual of the carrierer vehicle
- The actual total weight is less than the permissible values for the total weight stated in the operating manual of the carrierer vehicle
- The sum of the permissible rear wheel load capacity is higher than the real rear wheel load capacity
- The sum of the permissible front wheel load capacity is higher than the real front wheel load capacity

If all conditions are met, the machine may be attached to this carrier vehicle.



You can use a sufficiently large weigh-bridge to determine the total weight, the rear axle load and the front axle load by weighing.

Road transport

Make sure that the condition of the machine conforms to traffic regulations

The machine must conform to current traffic regulations if you intend to drive it on public roads. This includes for example:

- Fitting lighting equipment, warning devices and protective devices
- Observing the permissible transport widths, transport weights, axle loads, tyre load-bearing capacity and total weights

The driver and owner of the vehicle are liable if traffic regulations are not observed.

Closing ball valves

If ball valves are provided on the hydraulic lines or the chassis cylinders, the ball valves must be closed for road transport. The accidental actuation of control devices on the carrier vehicle could otherwise cause movements on the machine. Accidents or damage to the machine may be caused as a result.

Check release cable for the quick-release coupling

Release cables must hang loose and must not, when in their lowered position, release the couplings of their own accord. Attached machines might otherwise come loose from the three-point linkage of their own accord.

Riding on the machine is strictly prohibited

People or objects must never be transported on the machine. Riding on the machine poses a risk to life and limb and is strictly prohibited.

Take altered driving and braking behaviour into account

Driving and braking performance is altered when the machine is attached to the tractor. Take the width and balancing weight of the machine into consideration, especially when cornering. A driving style which not adjusted to the road conditions can lead to accidents.

Drive at a suitable speed

Always adjust your driving speed to the road conditions. Driving at excessive speeds in poor road conditions can create extremely high forces which can severely load or overload the carrier vehicle and machine. Driving at unsuitable speeds can cause machine damage and lead to accidents.

Training required before commissioning

The machine must not be put into operation until the user has been given proper training by an employee of the dealer, a factory representative, or an employee of the manufacturer. Commissioning without training can lead to damage to the machine due to false operation or accidents can happen.

Ensure that the machine is in perfect working condition

Do not operate the machine unless it is in perfect working condition. Check all important components and replace any defective components before starting the machine. Defective components can cause damage to equipment and personal injury.

Putting the machine into operation

Do not remove the protective equipment

The protective equipment must not be removed or by-passed. Check all protective equipment before starting the machine. Unprotected machine parts can cause serious or fatal injury.

Riding on the machine is strictly prohibited

People or objects must never be transported on the machine. Riding on the machine poses a risk to life and limb and is strictly prohibited.

Height of the machine and overhead power lines

If a height of 4.00 m is exceeded when folding the machine in and out, the machine must not be folded in the vicinity of live overhead power lines. Danger of electrocution! Should the machine come into contact with a live overhead power line:

- Do not leave the carrier vehicle.
- Do not touch any of the metal parts on the carrier vehicle.
- Do not create any conductive contact with the ground
- Warn anyone in the area not to approach the carrier vehicle or machine.
- Wait for help from professional emergency service personnel as power in the live overhead power line must first be switched off

Never climb onto the machine beneath live overhead power lines. The voltage can jump across even if the lines are not actually touching the machine.

Check the hazard area

Before driving off, folding out, and operating the machine and during operation, check its hazard area. Make sure that you have an adequate view. Do not begin work until the hazard area is cleared of any persons or objects. Information regarding the hazard area can be found in the corresponding chapter.

→ Chapter »Mulching«, Section »Task«, Page 38.

Parts could be ejected from the machine at high speed in certain circumstances. The hazard area, particularly in front of and behind the machine, must be cleared of any persons, animals or objects before starting.

Any use of the machine without verification of the hazard area can lead to serious or fatal accidents.

Retighten all nuts, bolts and screws

Nuts, bolts and screws should be checked at regular intervals and tightened if necessary. Screws can come loose unnoticed while operating. Damage to the machine or accidents may be caused as a result.

What to do in the event of a fault

In the event of a malfunction, shut down and secure the machine immediately. The fault may be eliminated immediately, or a specialist workshop must be assigned the task. Further operation of the machine can lead to damage to the machine or injury to persons.

Uncoupling the machine

Increased risk of injury

There is an increased risk of injury when uncoupling the machine from the carrier vehicle. Therefore:

- Secure the carrier vehicle so that it cannot roll away.
- Never stand between the carrier vehicle and the machine during uncoupling.
- Actuate the power lever slowly and carefully.
- Make sure the machine is standing on a secure and level surface
- Do not disconnect the hydraulic hoses until the hydraulic system of the carrier vehicle and machine is de-pressurised.

Failure to observe these instructions can result in serious or fatal injury.

Care and maintenance

Observe the care and maintenance intervals

Observe prescribed intervals for maintenance checks and inspections specified in the operating manual. If these periods are not observed, this can lead to damage to the machine, poor quality of work or accidents.

Use original replacement parts

Many components have special properties that are essential for the stability and correct operation of the machine. Unsuitable spare parts or accessory parts or incorrectly performed repairs or changes can cause damage to the machine, accidents or serious injury.

Müthing strongly recommends using only approved original Müthing accessories and spare parts. Müthing can guarantee the safety, reliability and suitability of these parts only.

Use of non-original Müthing spare parts shall invalidate any warranty claims.

When performing any care and maintenance work:

- Switch off the PTO stub shaft
- Depressurise the hydraulic system
- If possible, uncouple the carrier vehicle.
- Make sure the machine is standing securely. Provide additional support as required
- Do not use parts of the machine as climbing aids; use only secure steps, ladders or other means of access
- Secure the machine against rolling away
- Never reach into the V-belt while it is moving

It is only possible to guarantee work safety during care or maintenance work through observing these regulations.

Turn off the electrical supply

Prior to carrying out work on the electrical system, disconnect the system from the power supply. Systems supplied with electrical power can cause damage to equipment and personal injury.

Replace hydraulic hoses

Replace hydraulic hoses every six years. Hydraulic hoses can age without any externally visible damage. Defect hydraulic lines can lead to severe or fatal injuries.

Caution when cleaning with a high-pressure cleaner

The machine can be cleaned using either water or a steam jet. Only use a low pressure to clean bearings, fans, signal mixer units, plastic parts and hydraulic hoses. Excessively high pressures can cause damage to these parts.

Before carrying out welding work, disconnect the battery and alternator

Before carrying out any electric welding work on the attached machine, disconnect the battery of the carrier vehicle and disconnect the alternator. This avoids damage to the electrical system.

Tighten all screwed connections

All screw connections that are released during maintenance and repair work must now be retightened. Loose screwed connections can cause bolts to undo without you noticing during your work. As a result, machine parts can become detached. Otherwise, this may result in severe injury or damage to equipment.

Further regulations

Observe the regulations

In addition to these safety instructions, observe the following:

- Accident prevention regulations
- Generally recognised safety regulations, occupational health requirements and road traffic regulations
- Information and instructions in this operating manual
- Operation, maintenance and repair instructions

Familiarising yourself with the machine

This chapter contains general information on your machine as well as information on:

- Range of application
- Features
- Designation of components
- Technical specifications

Range of application of the machine

The machine is only allowed to be used for its intended purpose in landscaping or similar fields of work in accordance with its tooling.

Tool	Purpose
Carbide M shackle flails	To cut grass, other growth or sections up to a maximum of 2 cm diameter. The shackle flails can deviate sideways. As they are made from carbide, the flails can be used for longer and need to be replaced less often.

Since the conditions of use are very varied, the user must pay particular attention to the machine's performance limits. The machine must be switched off immediately if there is any indication of overstress.

Proper use

The machine should only be used for the designated work as described in this operating manual. Any application other than or beyond this is considered improper use.

Examples of improper use:

- Transporting persons or objects
- Cutting of any products other than those specified or those of a similar nature

→ »Range of application of the machine«

- Transferring power to other objects
- Front mounting of machines designed for rear mounting
- Rear mounting of machines designed for front mounting
- Working depths under 25 mm clearance from ground
- Any type of ground work
- Use of the machine in a position in which the tools do not point towards the ground, for example in a vertical position

The manufacturer and dealers are not liable for damage caused by improper use. The risk is borne solely by the user.

Familiarising yourself with the machine

Features of the machine

Robust housing in optimised form

The housing is particularly robust for heavy use and is designed in an optimised form.

Power transmission

In the case of mechanically driven machines, power is transmitted to a gear box using a PTO shaft. From there, the rotor is driven via V-belt. From there, the rotor is driven via V-belt.

In the case of hydraulically driven machines, power is transmitted directly to a V-belt pulley using a hydraulic motor. From there, the rotor is driven via V-belt.

Safety

The machine is constructed in accordance with EU regulations, for maximum possible safety of operation. The machine bears the CE mark and the UKCA mark.

Familiarising yourself with the machine

Designation of components

Mechanical drive

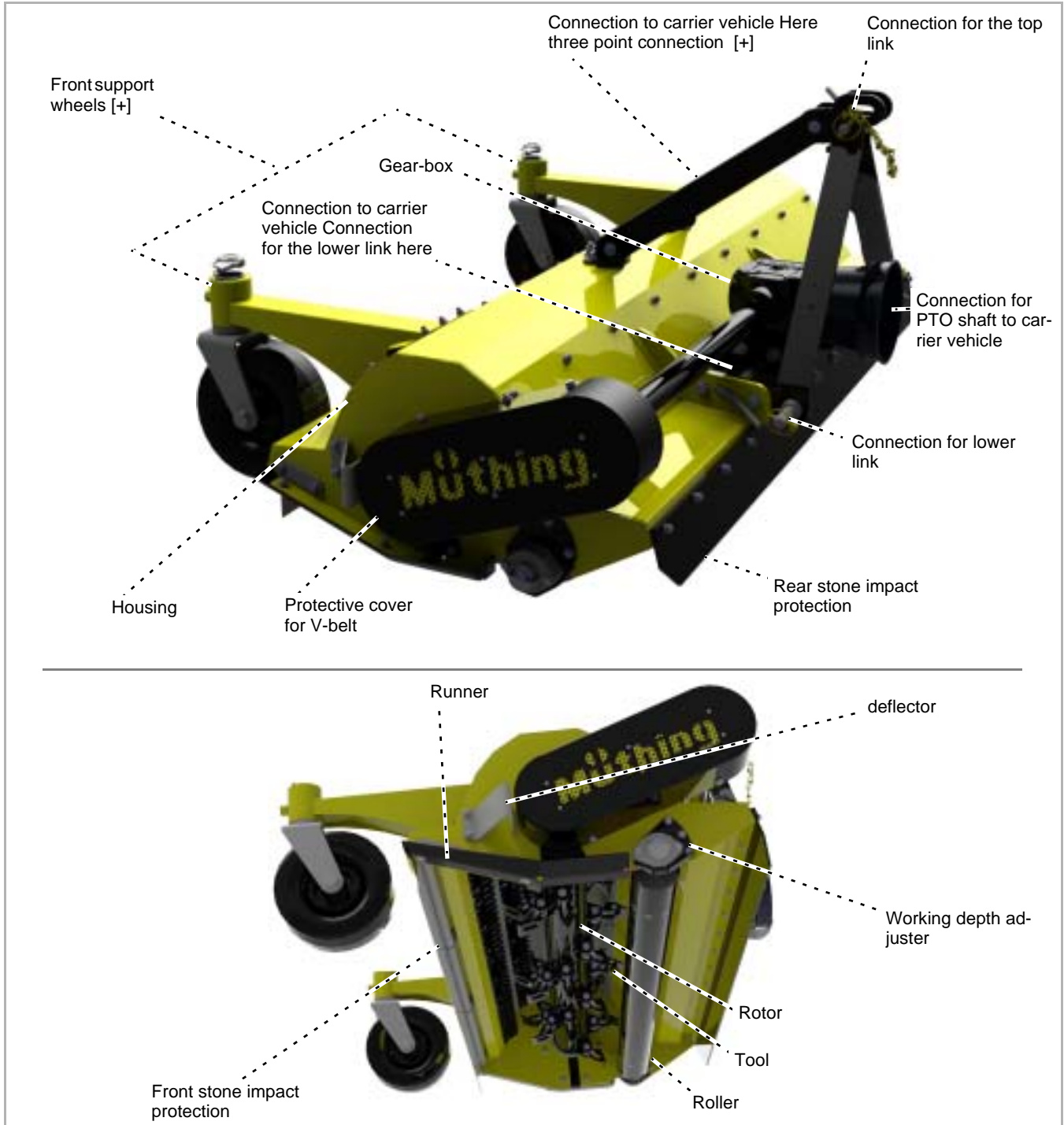

Familiarising yourself with the machine

Hydraulic drive

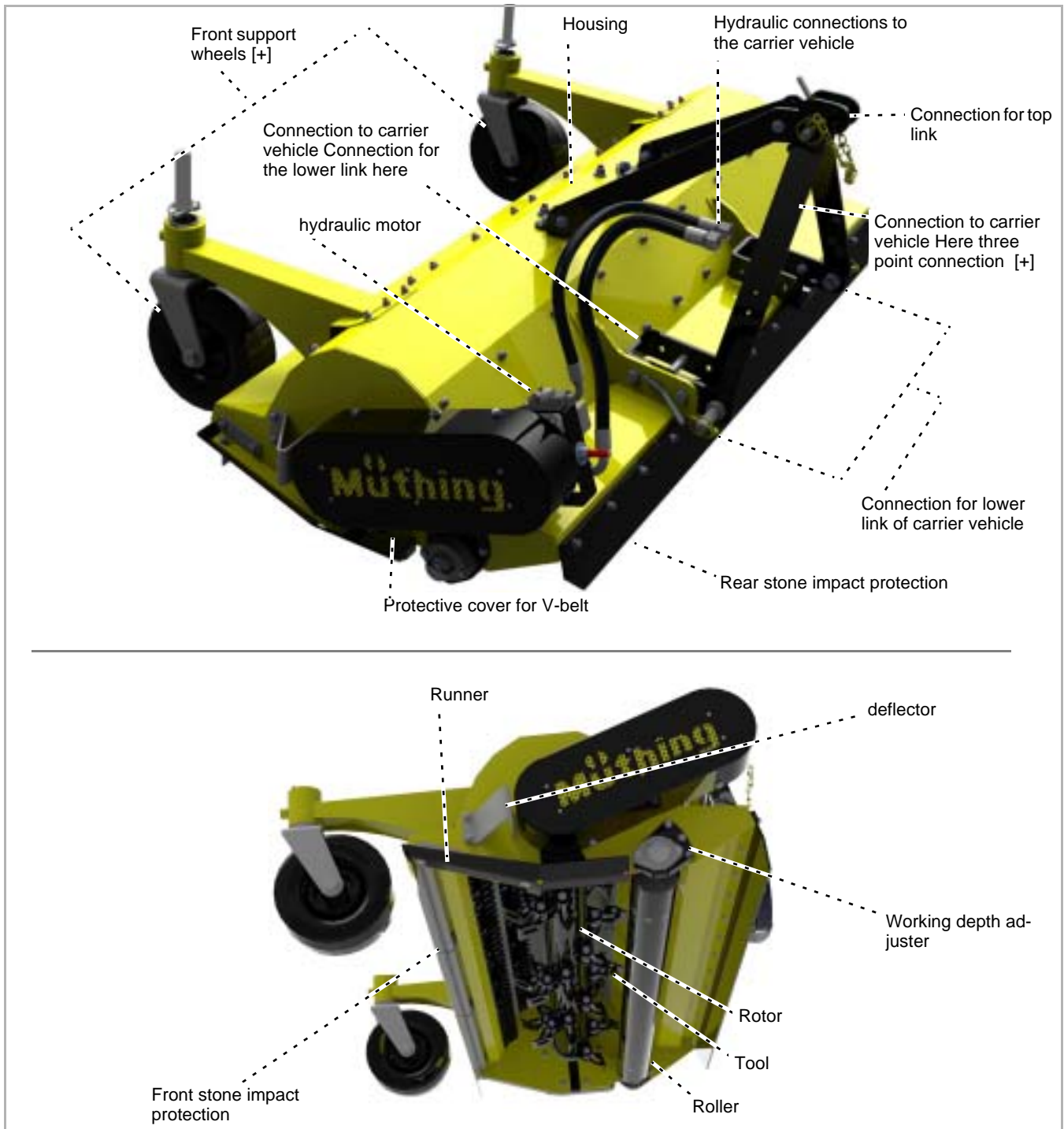

Familiarising yourself with the machine

Technical specifications

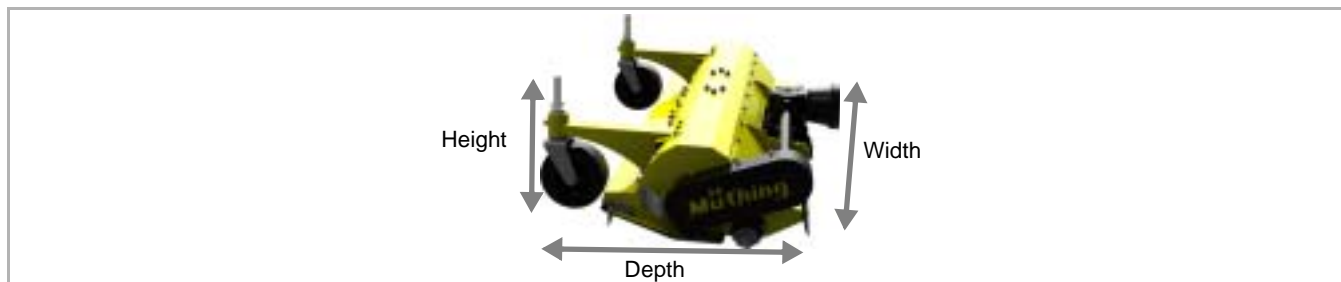

Mechanical drive

	Mechanical drive			
	MU-C 100	MU-C 120	MU-C 140	MU-C 160
Height [m]				
Without support wheels	0.72	0.72	0.72	0.72
With support wheels	0.72	0.72	0.72	0.72
Width [m]				
In work position	1.20	1.40	1.60	1.80
In transport position	1.20	1.40	1.60	1.80
Depth [m]				
Without support wheels	0.85	0.85	0.85	0.85
With support wheels	1.16	1.16	1.16	1.16
Working width [m]				
In work position	1.00	1.20	1.40	1.60
Total weight [kg]				
Without support wheels	151	178	195	216
With support wheels	1.83	210	226	248
Centre of gravity (dimension G)				
Without support wheels	0.39	0.39	0.39	0.39
Depending on equipment level, approx.	0.47	0.47	0.47	0.47
Rotational speed of rotor [rpm]				
PTO stub shaft 1000 2000 rpm	2660	2660	2660	2660
Power requirement [kW]				
Minimum	9	9	9	9
Maximum permitted	26	26	26	26
Working depth [mm]				
Without support wheels, in 10 mm steps	16-55	16-55	16-55	16-55
With support wheels, in 15-mm steps	16-55	16-55	16-55	16-55
Number of tools				
Carbide M shackle flails	16	20	24	28
Lubricants				
Transmission oil	SAE 90 EP	SAE 90 EP	SAE 90 EP	SAE 90 EP

Familiarising yourself with the machine

	Mechanical drive			
	MU-C 100	MU-C 120	MU-C 140	MU-C 160
Category	KAT 1	KAT 1	KAT 1	KAT 1
Paint colors				
Yellow	RAL 1007	RAL 1007	RAL 1007	RAL 1007
Black	RAL 9005	RAL 9005	RAL 9005	RAL 9005
PTO shaft				
Model	GE2101	GE2101	GE2101	GE2101
Noise level [dbA]				
In the workplace	< 85	< 85	< 85	< 85

Hydraulic drive

	Hydraulic drive			
	MU-C Hydro 100	MU-C Hydro 120	MU-C Hydro 140	MU-C Hydro 160
Height [m]				
Without support wheels	0.40	0.40	0.40	0.40
With support wheels	0.52	0.52	0.52	0.52
Width [m]				
In work position	1.20	1.40	1.60	1.80
In transport position	1.20	1.40	1.60	1.80
Depth [m]				
Without support wheels	0,76	0,76	0,76	0,76
With support wheels	1.04	1.04	1.04	1.04
Working width [m]				
In work position	1.00	1.20	1.40	1.60
Total weight [kg]				
Without support wheels	136	152	168	184
With support wheels	170	185	200	215
Centre of gravity (dimension G)				
Without support wheels	0.28	0.28	0.28	0.28
Depending on equipment level, approx.	0.36	0.36	0.36	0.36
Rotational speed of rotor [rpm]				
Hydraulic drive	2635	2635	2635	2635
Power requirement [kW]				
Minimum	13	13	13	13
Maximum permitted	29	29	29	29
Working depth [mm]				
Without support wheels, in 10 mm steps	16-55	16-55	16-55	16-55
With support wheels, in 15-mm steps	16-55	16-55	16-55	16-55

Familiarising yourself with the machine

	Hydraulic drive			
	MU-C Hydro 100	MU-C Hydro 120	MU-C Hydro 140	MU-C Hydro 160
Number of tools				
Carbide M shackle flails	16	20	24	28
Lubricants				
Transmission oil	SAE 90 EP	SAE 90 EP	SAE 90 EP	SAE 90 EP
hydraulic oil	HLP46	HLP46	HLP46	HLP46
Noise level [dB(A)]				
In the workplace	< 85	< 85	< 85	< 85
Category				
Individual adapter for each carrier vehicle				
Paint colors				
Yellow	RAL 1007	RAL 1007	RAL 1007	RAL 1007
Black	RAL 9005	RAL 9005	RAL 9005	RAL 9005
Hydraulic drive				
Hydraulic motor type 1				
Oil quantity in l/min at 180 bar	32	32	–	–
Oil quantity in l/min at 180 bar	–	–	50	50
Hydraulic motor type 2				
Oil quantity in l/min at 180 bar	32	32	50	50
Connections required on carrier vehicle	x	x	x	x
1 x feed				
1 x pressureless return line				
Depending on type of hydraulic motor:				
1 x leak-off oil line, depressurised				

Delivery and assembly

Checking the scope of delivery

The machine is delivered completely assembled. If parts of the machine have not been assembled, please contact your dealer.



Do not assemble the machine yourself

Do not perform assembly work yourself since requirements for an orderly condition of the machine are :

- Observance of a sequence of worksteps
- Compliance with tolerances and torques

Incorrect assembly may result in damage to the machine or poor performance.



If parts are missing or have been damaged during transportation, please submit a claim immediately to your dealer, importer or the manufacturer.

The machine must be fitted with a suitable adaptor in order to be attached to a carrier vehicle. Before attaching the machine, you should therefore check whether the correct adaptor for your carrier vehicle is present on the machine. Only use carrier vehicles from the list below.

If you do not have the correct adaptor:

- ▶ Contact your dealer or the manufacturer. They will be able to supply the correct adaptor.

Rigid implement triangles

Cat. 0 implement triangle

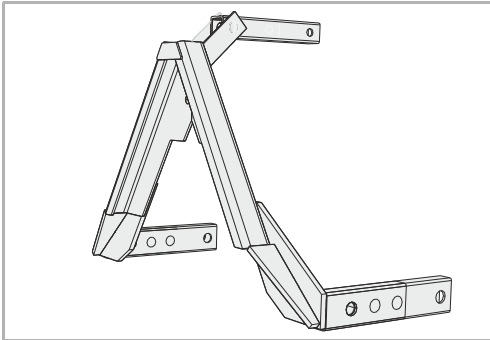

Standard implement triangle for attachment of front-mounted implement to carrier vehicles with tractor triangle with the following category:

- 0

Attachment kits

Mounting set Ibex

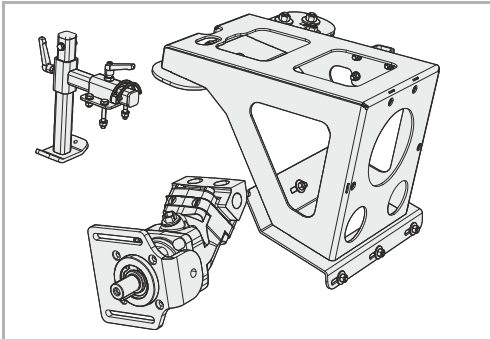

Attachment kit for attachment of front-mounted implement to carrier vehicles. The use of the mounting set is only allowed for machines with hydraulic drive

- Ibex Terra Tec

Adapter MU-C

Swivelling implement triangles

Swivelling implement triangles allow the machine to follow the soil contour.

Implement triangle Hako

Implement triangle for front mounting with carrier vehicles:

- With Hako implement triangle

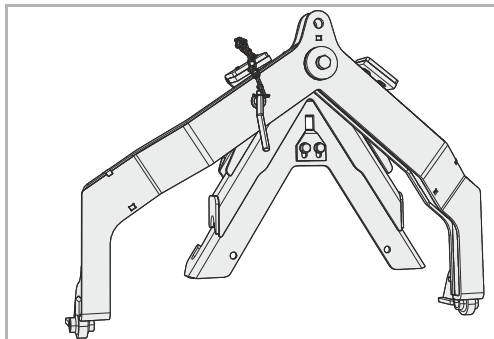

Adapter frame

Kärcher adapter frame

The adapter frames can be used only for machines with hydraulic drive.

For attachment of front-mounted implement to carrier vehicles

- Kärcher MIC 26
- Kärcher MIC 34

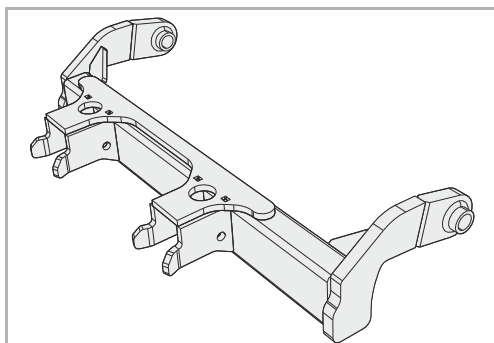

Shibaura adapter

For attachment of front-mounted implement to carrier vehicles

- Shibaura CM 214

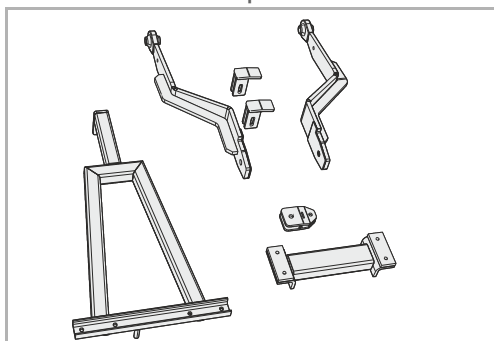

Husquvarna adapter

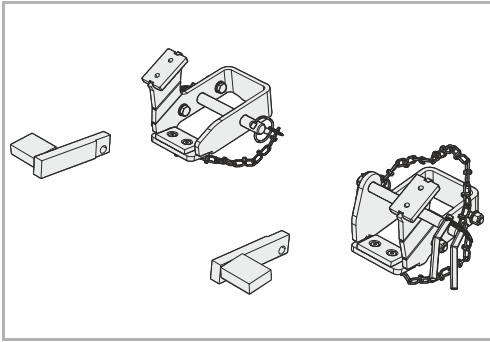

Mounting for carrier vehicles in front mounting with PTO shaft:

- PT 520
- PT 525

Iseki adapter

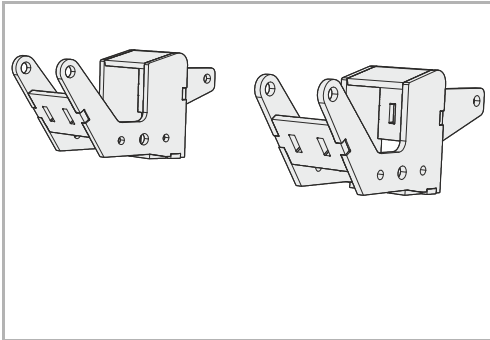

For attachment of front-mounted implement to carrier vehicles

- SFH

Coupling the machine



Increased risk of injury

There is an increased risk of injury when the machine is being coupled to the carrier vehicle. Therefore:

- Secure the carrier vehicle so that it cannot roll away.
- The carrier vehicle must be fitted with an adaptor for the machine.
- Never stand between the carrier vehicle and the machine during coupling.
- Actuate the power lever slowly and carefully.

Failure to observe these instructions can result in serious or fatal injury.



Machine for front mounting only

The machine is only allowed to be attached to the carrier vehicle at the front.

You can damage the machine if you mount it at the rear.

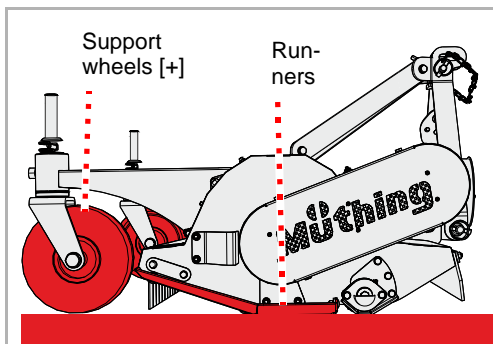

- ▶ Check that the machine is securely positioned. The support wheels and runners should be on the ground.
- Chapter »Parking and storage« paragraph »Setting down the machine in a secure position«, page 42

If the machine is not securely positioned:

- ▶ Secure the machine with suitable lifting gear and move into the correct position

Implement triangles

Requirement: Your carrier vehicle is fitted with an implement triangle and the machine is fitted with the corresponding receiver.

- ▶ Drive the carrier vehicle up to the receiver on the machine so that it is centrally positioned.
 - ▶ Lower the implement triangle on the carrier vehicle so that it fits under the receiver on the machine.
 - ▶ Drive the carrier vehicle up to the receiver on the machine.
 - ▶ Raise the implement triangle, making sure that it latches into the receiver securely.
 - ▶ Secure the implement triangle in the receiver.
- Implement triangle operating instructions

Two-point connection

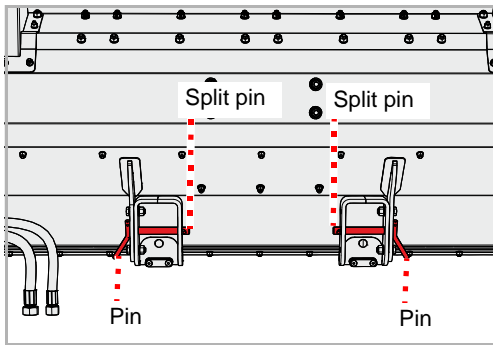

Requirement: Your carrier vehicle is fitted with the appropriate lift arm.

- ▶ Remove the split pins and take out the pins
- ▶ With the carrier vehicle centrally positioned, drive up to the machine, paying attention to the position of the lift arms in relation to the machine.

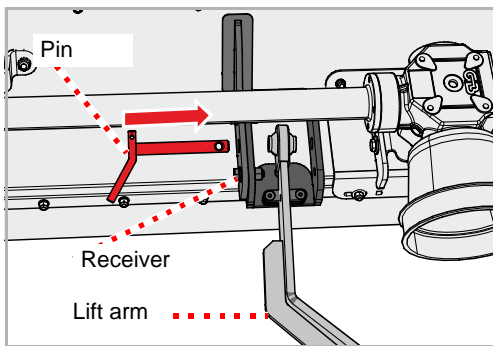

- ▶ Align the lift arms so that they fit into the receivers on the machine
- ▶ Secure the lift arm with the pin, secure the pin with the split pin

Three point linkage

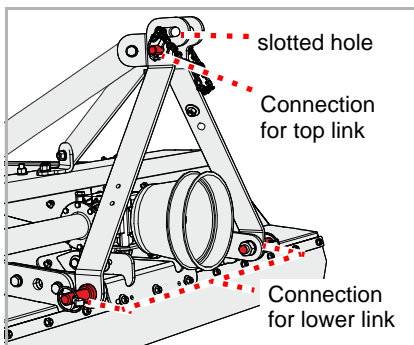

- ▶ Adjust both lower links on the tractor to the same height
- ▶ Connect lower link according to the category of tractor and secure with pin and linchpin
- ▶ Connect top link according to the category of the tractor and secure with pin and linchpin



For transport use round holes in the top link linkage. The slotted hole is intended for use of the machine in the field.

Coupling the machine

Mechanical drive

PTO shaft

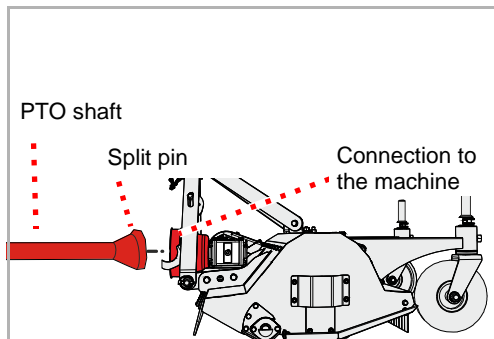

The PTO shaft has been adapted by your dealer in line with your carrier vehicle.

Generally, the PTO shaft is already connected to the machine. If the PTO shaft is replaced or after maintenance work to the PTO shaft, it will be necessary to connect it to the machine.

- ▶ Carefully clean and grease the PTO shaft and connection to the machine
- ▶ Push the PTO shaft onto the connection to the machine and ensure that the cotter pin locks into place on the PTO shaft

Connection to carrier vehicle



If you switch to a different carrier vehicle, you must check that the PTO shaft is the right length. It is particularly important when checking the PTO shaft to ensure that the two halves of the PTO shaft continue to overlap at the position in which the PTO shaft is pulled apart furthest.

If you switch to a different carrier vehicle, you must make sure that the PTO shaft is suitable for the new carrier vehicle. If necessary, you must swap the PTO shaft for a new one and have it adapted in a qualified specialist workshop.

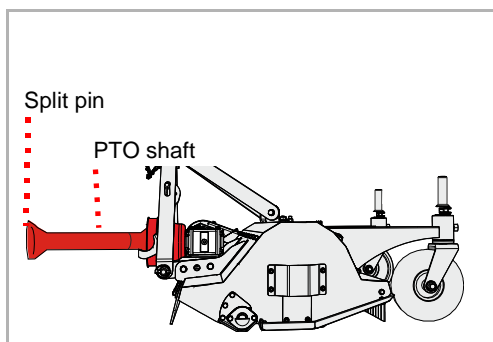

- ▶ Connect the propeller shaft to the PTO shaft of the carrier vehicle. Make sure that the split pin on the propeller shaft latches into place

Hydraulic drive

Function	Color of dust cap
Feed line	Green
De-pressurised return	Green
Depressurised leak-off oil line	Blue

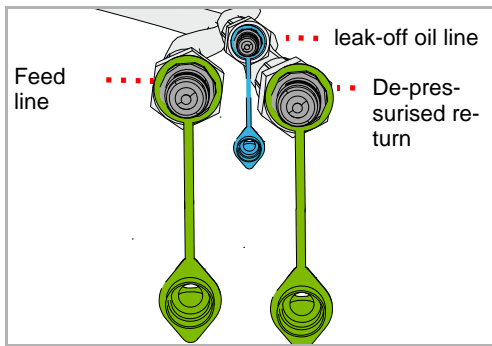

Machines with separate leak-off oil line:

- ▶ Connect the hydraulic hoses to the corresponding connections on the carrier vehicle

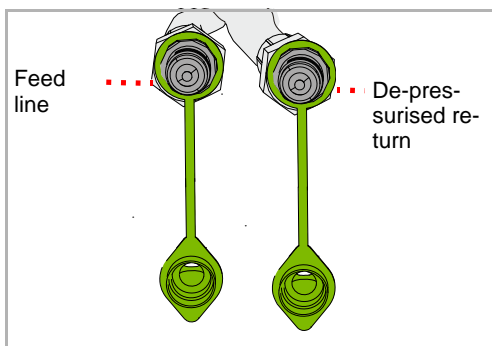

Machines with integrated overflow oil line:

- ▶ Connect the hydraulic hoses to the corresponding connections on the carrier vehicle

Preparation

Working width

Without support wheels, the working depth can be adjusted in 10 mm steps. With support wheels, the working depth can be adjusted in 15 mm steps.

The optimal working depth for most applications is the middle setting.



Tools must not come into contact with the ground

Any contact with the ground could result in stones or other material not being held back safely by the stone impact protection. *Persons even outside of the hazard area could be injured by ejected material.*

- ▶ Secure the carrier vehicle so that it cannot roll away.
- ▶ Raise the machine approximately 5 cm

Without support wheels



Always secure the adjustment plate with two bolts

The adjustment plate must always be secured with two bolts. If the adjustment plate is only secured with one bolt, the working depth could change by itself and the tools could come into contact with the ground.

Persons even outside of the hazard area could be injured by ejected material.

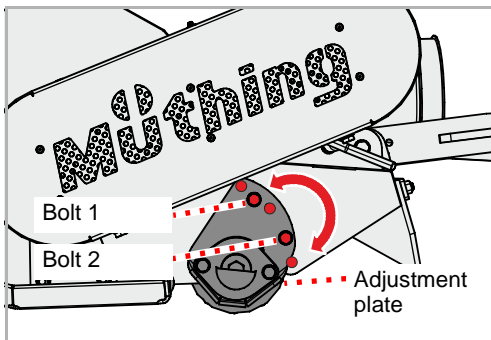

- ▶ Undo and remove the nuts on bolt 1 and bolt 2.
- ▶ Remove bolt 1 and bolt 2.
- ▶ Use the adjustment plate to adjust the working depth as desired.
- ▶ Secure the adjustment plate with bolt 1 and bolt 2.
- ▶ Secure bolt 1 and bolt 2 with nuts.
- ▶ Make the same adjustment on the opposite side of the housing.

With support wheels

[+]

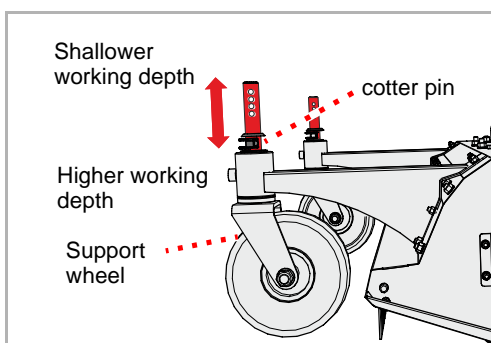

- ▶ Remove the cotter pin.
- ▶ Raise or lower the support wheel as required.
- ▶ Secure the support wheel again using the cotter pin.
- ▶ Make the same setting on the second support wheel.

Transport position

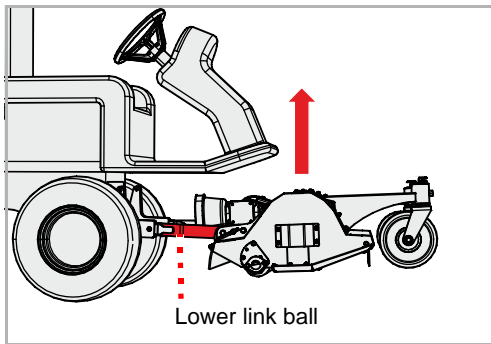

- ▶ Adjust the height of the lower links using the power lever of the carrier vehicle so that the machine is high enough for transport.
 - ▶ Secure the control devices on the carrier vehicle so that they cannot be actuated accidentally.
- Operating manual of carrier vehicle

Transport without coupling

For transport on, for example, a trailer, the machine can be raised. Only use the designated points for attaching the lifting device. The machine must be securely positioned.

- ▶ Setting down the machine in a secure position
- Chapter »Parking and storage« paragraph »Setting down the machine in a secure position«, page 42
- ▶ Attach suitable lifting devices to the lifting eyes
 - ▶ Raise the machine with suitable lifting gear and position on the loading bed
 - ▶ Secure the machine against slipping

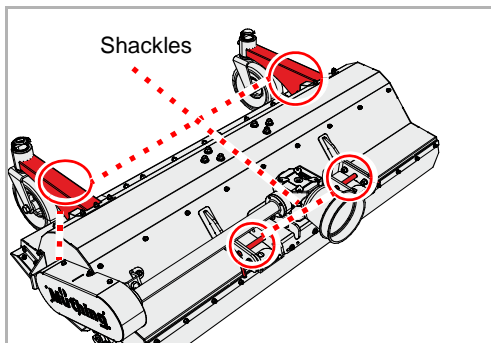

Mulching

Task

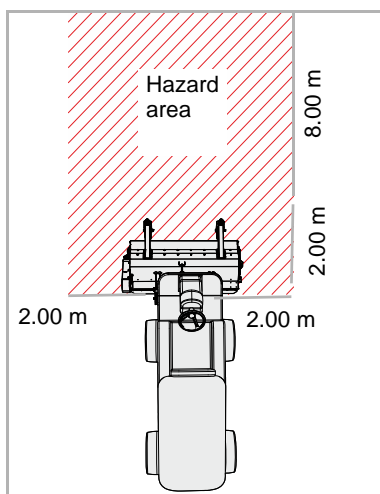

Check the hazard area

The hazard area in front of the machine is 8 m. It is 2 m at the sides. Before driving off, operating the machine and during operation, check its hazard area. Make sure that you have an adequate view. Do not begin work until the hazard area is cleared of any persons or objects.

Parts could be ejected from the machine at high speed in certain circumstances. The hazard area, particularly in front of and behind the machine, must be cleared of any persons, animals or objects before starting.

Any use of the machine without verification of the hazard area can lead to serious or fatal accidents.

Assess the dust exposure levels

If the ground and the material to be mulched are dry, you may be exposed to dust. Dust exposure can be avoided by taking into account the direction of the wind. If dust exposure cannot be avoided, you can protect yourself by wearing a dust mask. If these measures are not sufficient, use a carrier vehicle with an enclosed cab and a dust filter.

Dust exposure may lead to respiratory diseases.



Only work forwards

The machine may only be located in work position when moving forwards. The machine must be raised up when reversing.

A machine in work position when reversing could result in serious damage to the machine.

Particular care should be taken by the operator when working with the mulcher. Working on ditches, overhangs or slopes are activities which tend to be particularly hazardous. We can only give general instructions, the actual situation must be evaluated by the operator.

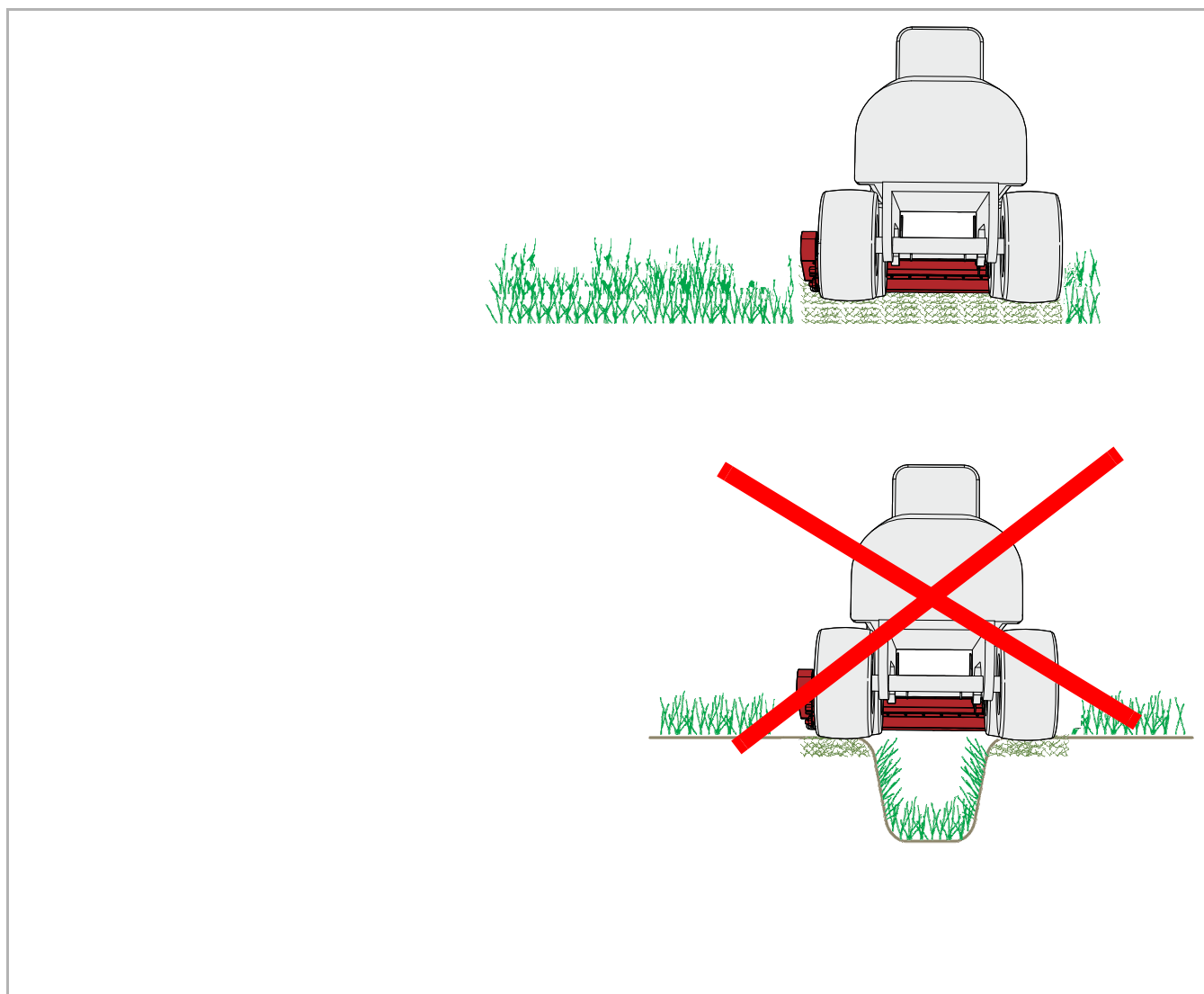



Do not lean the machine forwards

The machine must not lean forwards or backwards during work. A machine that is leaning forwards or backwards can become clogged up and work incorrectly.

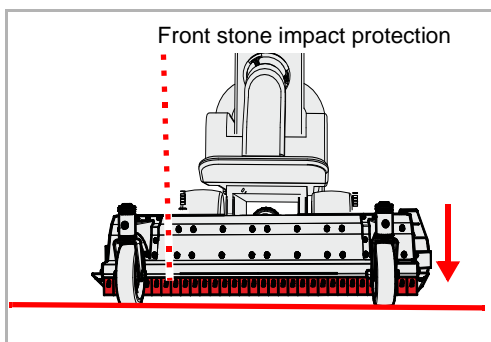

- ▶ Lower the machine using the carrier vehicle until the machine is on the ground. The front stone impact protection device should be parallel to the ground.
- ▶ Place the control device on the carrier vehicle for the lower links into the floating position.

In the case of machines with a mechanical drive:

- ▶ Switch the PTO stub shaft into the work position and slowly bring the machine to the rated speed

In the case of machines with a hydraulic drive:

- ▶ In the work position, switch on the hydraulic drive and slowly bring the machine up to its rated speed.

- ▶ Then drive at low speed into the stock, increase speed slowly. Pay attention to the machine while doing this.

If the machine is working too hard:

- ▶ Reduce speed
- ▶ Drive at a suitable speed. The speed must be appropriate to the growth and the type of terrain.

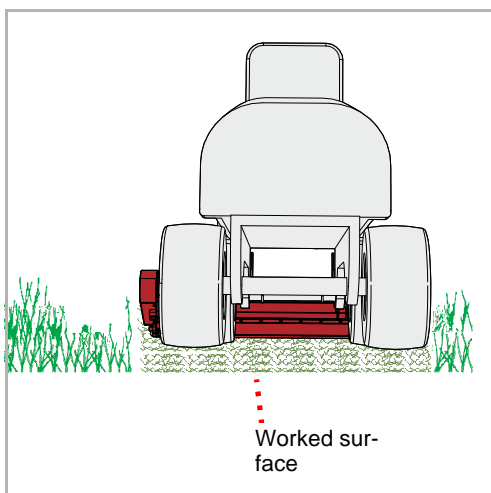

Cleaning

A high-pressure cleaner, for example, can be used to clean the machine. Never point the water jet directly at the labels or type plate.



Only use low pressure to clean the bearings

Only use low pressure to clean the bearings.

The ingress of water shortens the service life of the bearings



We recommend that you lubricate all bearings after cleaning. This forces any water which has found a way into the bearings back out and increases the service life of the machine.

Care

To ensure the machine's long service life, we recommend applying a protective coating of oil after the end of the season and during storage.



Use only approved and biodegradable oil, e.g. rapeseed oil.

Parking and storage

Setting down the machine in a secure position



Ensure that there are no unauthorised persons can enter the set-down location

If the machine is set down either coupled to the carrier vehicle or uncoupled, you must make sure that it is protected so that unauthorised persons have no access to it.

Persons could be injured by coming into contact with parts of the machine or by manipulating the machine.



Select the set-down location carefully

The set-down location must be relatively even and the ground must be solid.

Uneven or soft ground could result in the machine rolling away and becoming damaged.

Requirements on the set-down location:

- Horizontal, solid surface
- Sufficient room on all sides
- Protected against access by unauthorised persons, such as children

Hydraulics



Increased risk of injury

There is an increased risk of injury when uncoupling the machine from the carrier vehicle. Therefore:

- Secure the carrier vehicle so that it cannot roll away.
- Never stand between the carrier vehicle and the machine during uncoupling.
- Actuate the power lever slowly and carefully.

Failure to observe these instructions can result in serious or fatal injury.

- ▶ Disconnect the hydraulic hoses from the connections on the carrier vehicle
- ▶ Protect the plug with the dust cap and lay it down on the machine

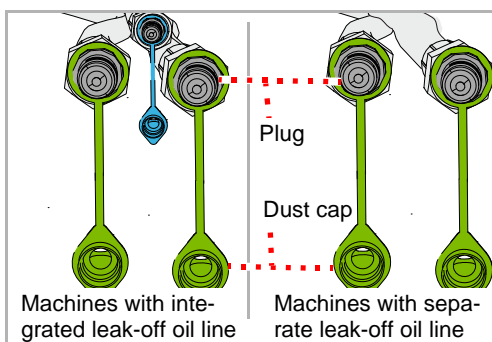

PTO shaft

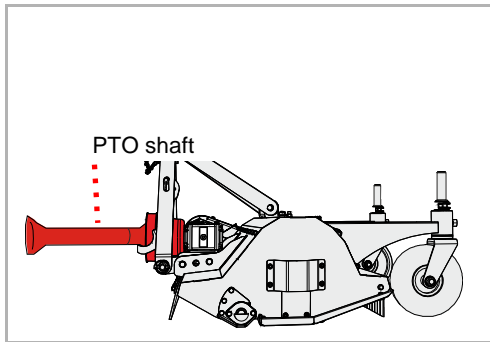

- ▶ Disconnect the PTO shaft from the carrier vehicle.

Coupling triangle

- ▶ Lowering the machine
- ▶ Undo the retainer between the implement triangle and the receiver
- Implement triangle operating instructions
- ▶ Lower the implement triangle
- ▶ Move the carrier vehicle backwards and away from the machine.

Two-point connection

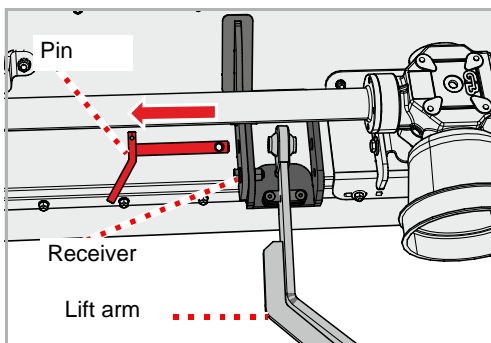

- ▶ On both sides, remove the split pins and the pins
- ▶ Move the carrier vehicle backwards and away from the machine.
- ▶ Replace the pin and secure with the split pin

The machine is now safely set down.

Three point linkage

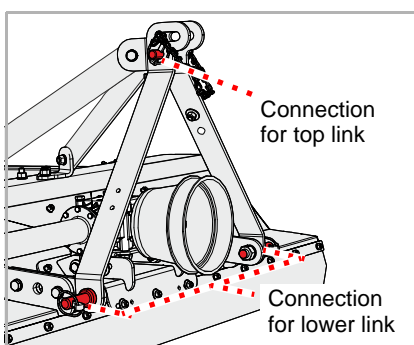

- ▶ Remove the top link
- ▶ Undo the lower link and lower

The machine is now safely set down.

Storing the machine

After cleaning, the machine should be stored in transport position in a dry location and on a level and stable surface.
→ Section »Setting down the machine in a secure position«, Page 42



Apply a protective coating of oil during storage. Use only approved and biodegradable oil, e.g. rapeseed oil.
→ Chapter »Cleaning and care«, starting at page 41

For your safety

Special safety instructions



Requirements for conducting maintenance work

Only perform the maintenance work if you have the required expert knowledge and suitable tools.

A lack of specialist knowledge or the use of unsuitable tools can cause accidents.

Protect the machine from being started up accidentally

If the machine is coupled, only carry out repair and maintenance work and only rectify malfunctions on it if:

- The PTO stub shaft is off
- The engine is switched off
- The ignition key is removed

Serious accidents may be caused if the machine starts accidentally.



Welding work

Welding work is only allowed to be carried out by persons trained in welding who also have specialist knowledge of repairing landscaping machinery. Welding work which negatively impacts the machine's construction is prohibited.

Incorrect welding work could impair or destroy the machine's function. If in doubt, contact your dealer before carrying out any welding work.

Use replacement parts with identical properties

Many components have special properties that are essential for the stability and correct operation of the machine.

When replacing components, dimensions, stability and material quality must be guaranteed. We recommend the exclusive use of original replacement parts.

Use of replacement parts which do not correspond to requirements could cause damage to the machine or impaired performance.

Protective measures when handling oils or lubricants

Additives in oils and lubricants may have adverse effects on health. Since the hazardous material code does not require any special identification, please always observe the following:



Avoid skin contact

Avoid skin contact with these materials.
Contact can result in skin damage.

Protect your skin

When handling oils and lubricants, protect your skin with lotion or wear oil-resistant gloves.
Oils can be hazardous to your health.

Do not use oils for cleaning

Do not use oils or lubricants to clean your hands.
Swarf and abraded material in these materials can also result in injuries.

Change out of soiled clothing

Change out of clothing that is heavily soiled with oil as soon as possible.
Oils can be hazardous to your health.



- Collect old oil and dispose of it in accordance with statutory regulations.
- If your skin becomes irritated by oil or lubricants, contact a doctor immediately.

General information

This information relates to general maintenance work. For all maintenance work, the machine must be locked in the work position. If it is necessary to put the machine in its transport position for maintenance work, you will see an appropriate reference in the maintenance instructions.



Working with the grease gun:

One or two strokes with the grease gun are sufficient for lubrication. If you feel resistance during the second stroke of the grease gun, do not complete it.

Too much grease will force the bearings apart. This could allow dust and dirt to enter the bearing, resulting in premature wear.

Maintenance

Fundamentals

The following table contains a brief explanation of the most important terms used for maintenance.

Task	Version
Greasing	<ul style="list-style-type: none">• Apply grease to the slide surfaces using a brush
Lubrication	<ul style="list-style-type: none">• 1 - 2 Unless specified otherwise, one or two strokes with the grease gun provide sufficient lubrication
Oiling	<ul style="list-style-type: none">• Unless otherwise specified, use only vegetable-based oil such as rapeseed oil• Mineral oils are not suitable• The use of used oil will endanger your health and is also strictly prohibited
Replacement	<ul style="list-style-type: none">• Replace the component in question according to the instructions in the »Maintenance« chapter
Check	<ul style="list-style-type: none">• An inspection may be required in conjunction with the replacement of the component in question
Observe the maintenance intervals	<ul style="list-style-type: none">• All information is based on average machine usage• In the case of heavy usage (e.g. contract work), shorten the maintenance intervals accordingly• Shorter maintenance intervals may also be required under extreme working conditions (e.g. heavy dust generation)

Screwed connections

Retighten screws

All bolts must be retightened:

- After the first hours of operation
- According to the frequency of use
- But at least once a season

General tightening torques

Tighten all screwed connections in accordance with the information in the table. If different tightening torques are necessary, they are specified in the chapter »Maintenance«. The minimum quality of the bolts is 8.8.

Bolt size	Quality of the bolts		
	„8.8“	„10.9“	„12.9“
	Tightening torques in Nm		
M6	9.9	14	17
M8	24	34	41
M10	48	68	81
M12	85	120	145
M16	210	290	350
M20	425	610	710
M24	730	1050	1220

Maintenance

Maintenance intervals and setting work

The information relates to average usage under the machine's normal operating conditions. Maintenance intervals are shorter for heavy usage, such as with hire companies, or for extreme operating conditions such as very dusty environments.

	After the first hours of operation	Once daily	After 30 hours of operation	After 75 hours of operation	Once per season	As required	In case of wear	grease / oil / lubricate	Check	Replacement	Cleaning
General											
Retighten all screws	•					•					
Visual inspection	•	•									
Bearing		•				•		•			
Pivots		•							•		
Hydraulics											
Hydraulic hoses Every 6 years										•	
Hydraulic hoses General						•	•			•	
Hydraulic cylinder		•		•		•		•	•		
Tools											
Fastenings on the rotor		•							•		
Condition, wear		•							•		•
Other											
Position of rotor		•						•			
Roller bearing		•						•			
Shafts and pins			•					•			
PTO shaft Protective cover		• •				• •		• •	• •	• •	• •
Transmission oil		•			•				•		•

Lubricating work

Lubricate bearings

The bearings must be lubricated regularly. Lubricate only with 1 - 2 strokes from the grease gun:

- According to the maintenance chart
- After heavy use
- But at least once a season

Bearings that require no maintenance must not be lubricated.

Maintenance

Overview of lubrication points

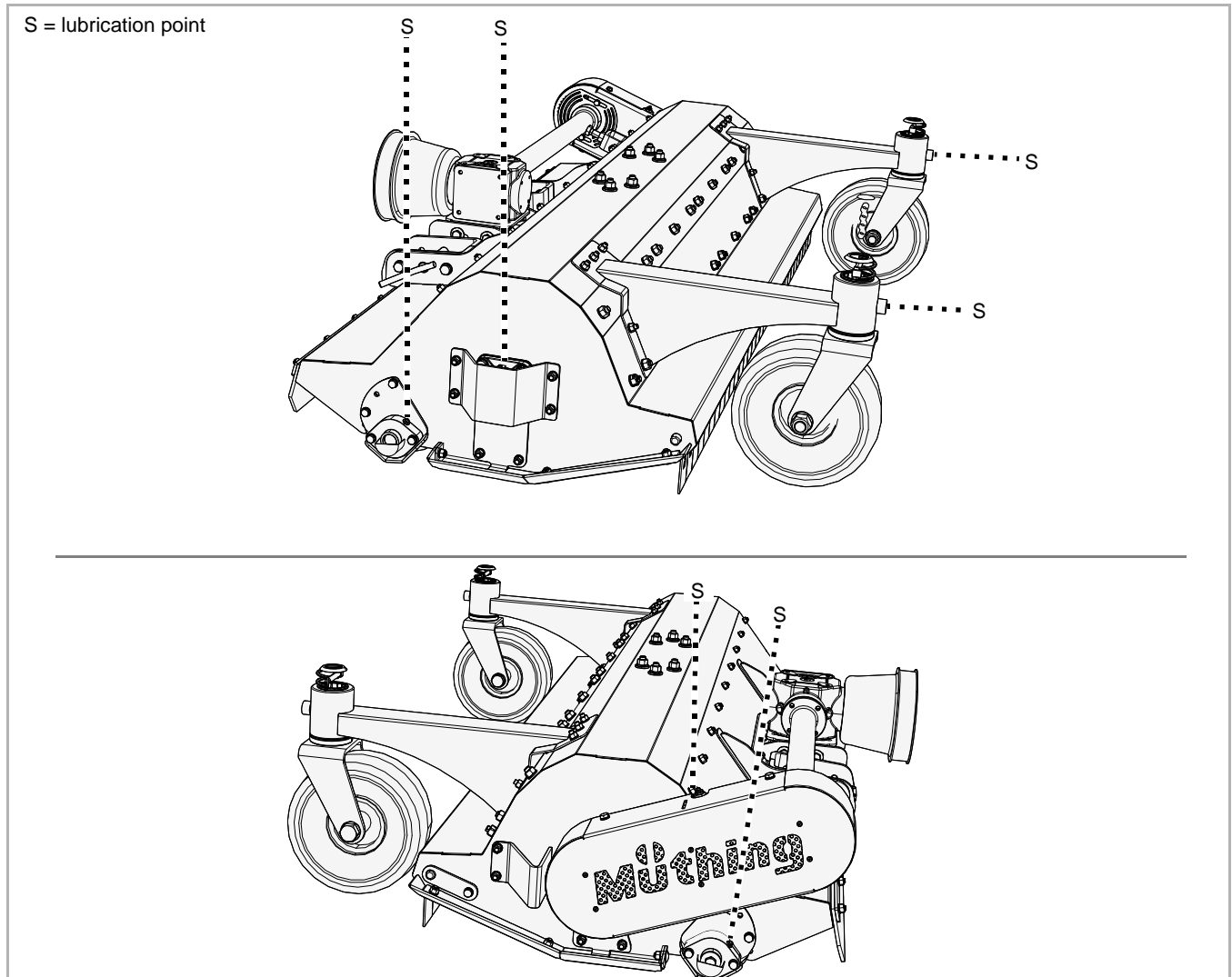

Other lubrication points

The following applies:

- In addition to the lubrication points shown in this operating manual, your machine may have other lubrication points
- As a rule, lubrication points are located at pivots or bearings. Therefore, inspect your entire machine for any such additional lubrication points.



The location of the lubricating nipple is usually shown on one component as an example. If multiple components of this kind exist, the lubricating nipples have to be lubricated at each of these components.

PTO shaft

The PTO shafts are heavily stressed. This means that regular maintenance is decisive for the PTO shafts' service life. Only the most important work is shown here.

Full maintenance work on the PTO shaft:

→ PTO shaft operating manual

Checking

Daily

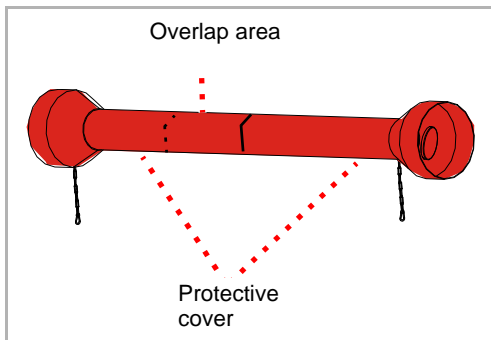

- ▶ Check the PTO shaft for contamination and clean if required. Dust in conjunction with oil and grease results in increased wear

If the PTO shaft is heavily contaminated:

- ▶ Clean PTO shaft
 - ▶ Grease the interior of the overlap area of the protective cover
- PTO shaft operating manual

- ▶ Check protective cover for damage

If the protective cover is damaged:

- ▶ Replace protective cover
- PTO shaft operating manual

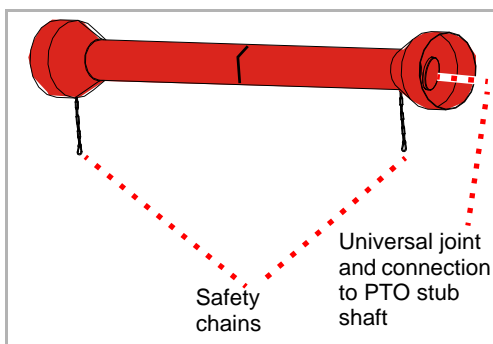

- ▶ Check presence and correct function of safety chains

If the safety chains are not present or are heavily worn:

- ▶ Replace the safety chains
- PTO shaft operating manual

- ▶ Check the PTO shaft for wear in the universal joints and at the connection to the PTO stub shaft

If the universal joints are heavily worn:

- ▶ Replace the universal joints
- PTO shaft operating manual

Lubrication

Every 50 hours of operation

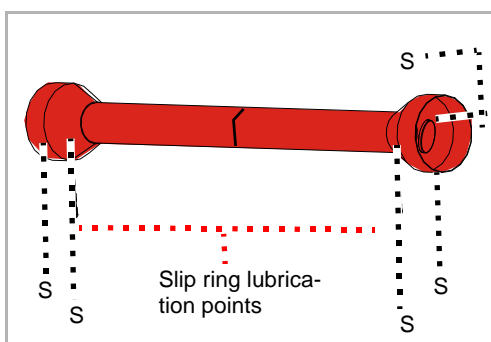

In case of heavy usage or in extreme operating conditions, such as a very dusty environment, more frequent lubrication is required.

- ▶ Lubricate in the universal joint with 1 - 2 strokes of the grease gun.
- ▶ Lubricate on the slip rings with 1 - 2 pumps of the grease gun

For wide-angle PTO shafts:

The wide-angle joint contains a lubricant reserve which must be filled with 400-500 g [14-17 OZ] of grease.

- ▶ Lubricate with at least 5-6 pumps of the grease gun
- PTO shaft operating manual

Maintenance

Transmission oil

The gearbox oil must conform to the specification.

→ Chapter »Familiarising yourself with the machine« paragraph »Technical specifications«, page 25

Check

Twice per season

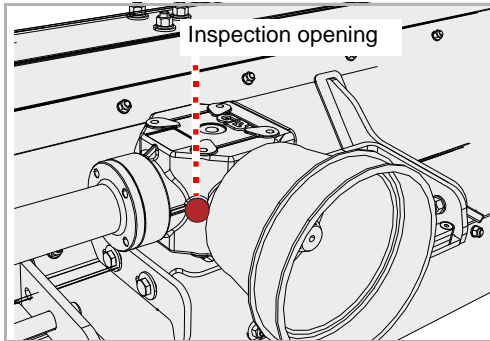

- ▶ Loosen the screw on the inspection opening with an Allen key and remove the screw
- ▶ Check the oil level. The oil level must reach the lower edge of the inspection opening.
- ▶ Retighten the screw at the inspection opening

Refilling

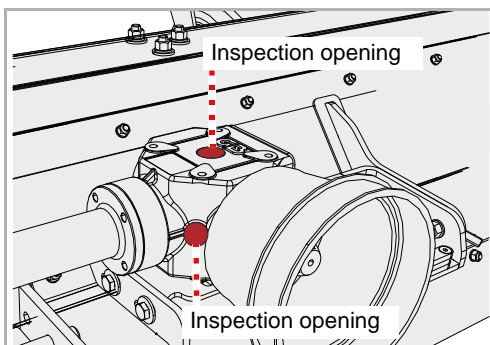

- ▶ Loosen the screw on the inspection opening with an Allen key and remove the screw
- ▶ Loosen the screw on the filler opening with an Allen key and remove the screw.
- ▶ Use a funnel to fill with gear oil of the appropriate specification until the oil level reaches the lower edge of the inspection opening
- ▶ Retighten the screw at the inspection opening
- ▶ Retighten the screw at the inspection opening

Replacement

1x per season

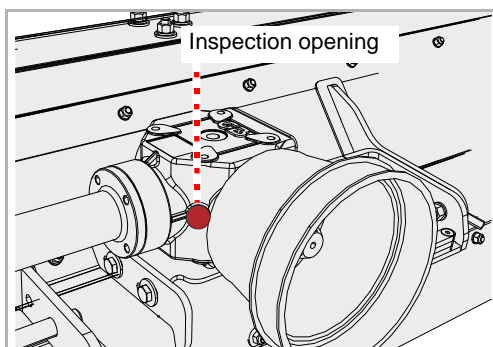
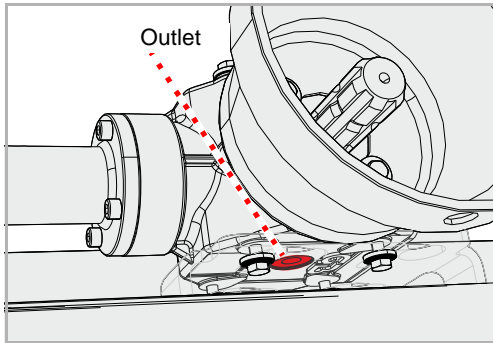

- ▶ Place a collection container under the outlet for the waste oil

 - ▶ Loosen the screw on the inspection opening using a hex key
 - ▶ Loosen the screw on the outlet with an Allen key and remove the screw
 - ▶ Allow the oil to drain out fully
 - ▶ Screw the screw on the outlet back in.
 - ▶ Refill with new gear oil
- Section »Refilling«

Maintenance

Tools

As required

The tools must be replaced if they:

- Are damaged
- Are heavily worn
- The bore on the tool is worn
- The fastening screws or the fastening nuts are worn

It is important that the rotor runs without unbalance. Therefore:

- Always replace tools with the same type
- Always replace tools opposite each other at the same time
- In case of wear it is best to replace the entire set of tools



Secure the machine

Work can only be carried out on a machine secured against rolling away and dropping. To prevent dropping, for example, permitted and correctly dimensioned support legs can be used.

If the machine is not secured against rolling away and lowering, serious or fatal accidents could result.



New tools – new nuts and bolts

When replacing the tools, the nuts and bolts must also be replaced. *If the nuts and bolts are not replaced, the worn bolts may break. Tools may become detached during work and be flung out. Even persons outside of the hazard area could be seriously injured or killed.*

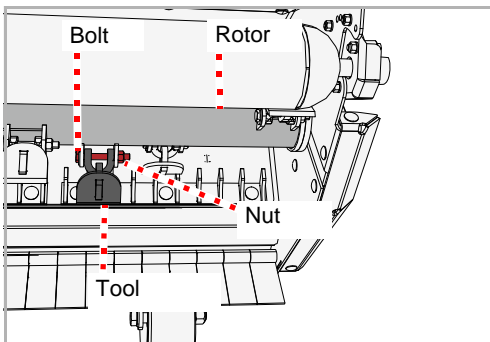

- ▶ Secure the machine against rolling away and dropping
- ▶ Loosen the nuts and remove the bolts
- ▶ Remove old tool
- ▶ Insert the new tool in the same way.
- ▶ Fit a new screw and secure with a new nut

V-belt

As required

Checking

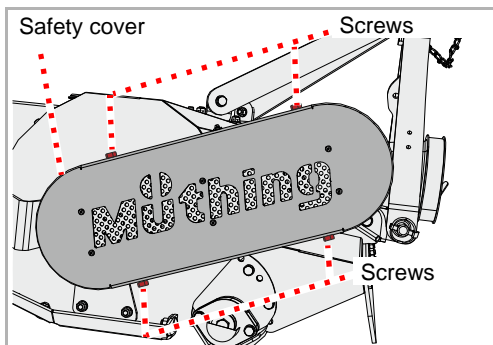
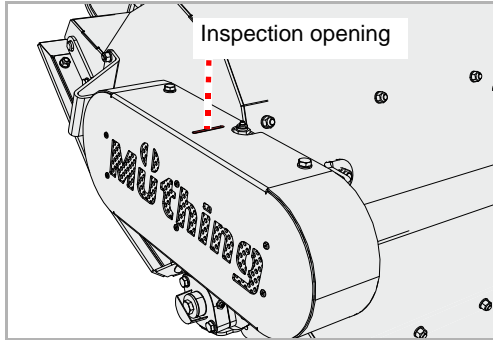

The V-belt is tensioned by a counterweight. If the V-belt is not sufficiently tensioned, it must be retensioned. If there are any tears or the V-belt is damaged, it must be replaced.

There is an inspection opening on the machine.

- ▶ Check the tension of the V-belt. When under a load of 6 kg, it must not be possible to push the V-belt through more than 10 mm.

- ▶ Remove the screws, remove the safety cover.
- ▶ Check the V-belt for damage
- ▶ Reassemble the safety cover

Maintenance

Tensioning

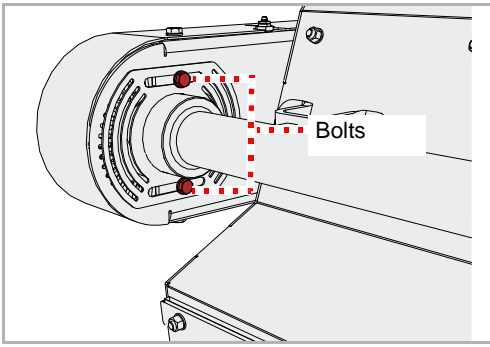

- ▶ Loosen the nuts but do not remove them.

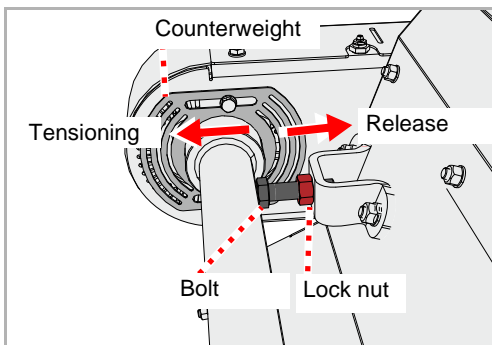

- ▶ Loosen the lock nut
- ▶ Use the bolt to set the V-belt tension as required via the counterweight
- ▶ Tighten the lock nut again.

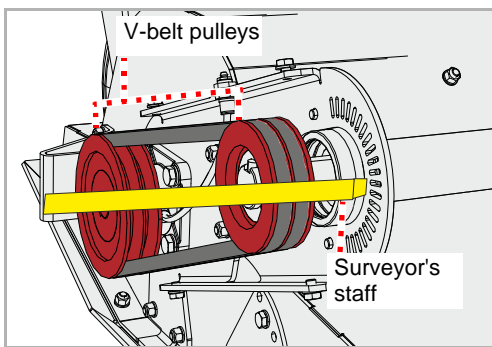

- ▶ Check the alignment of the V-belt pulleys. Use a surveyor's staff or similar. The surveyor's staff must lie flat on both V-belt pulleys and must be properly aligned.

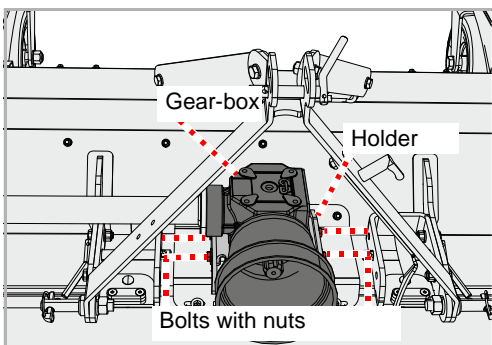

If the surveyor's staff does not lie flat:

- ▶ Undo the nuts on the bolts.
 - ▶ Move the holder with the gear-box until the surveyor's staff lies flat on both V-belt pulleys
 - ▶ Retighten the nuts on the bolts.
- ▶ Check the V-belt tension

Replacement

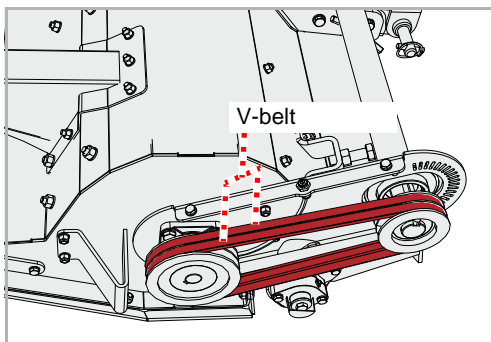
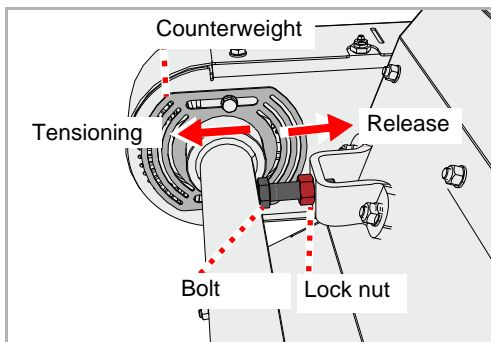
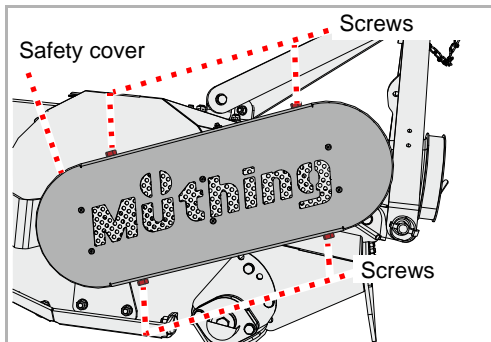

If there are any tears or other damage on the V-belt, it must be replaced.

- ▶ Remove the screws, remove the safety cover.

- ▶ Loosen the lock nut
- ▶ Use the bolt to slacken the V-belt tension

The V-belt unit consists of two narrow V-belts.

- ▶ Remove the old V-belts.
 - ▶ Fit the new V-belts
 - ▶ Check the V-belt for correct positioning
 - ▶ Tension the V-belt
- Section »Tensioning«, Page 56
- ▶ Reassemble the safety cover

Maintenance

Runners

As required

The runners protect the machine from direct contact with the ground. If they are not replaced in good time, the housing of the machine will be damaged.



Secure the machine

Work can only be carried out on a machine secured against rolling away and dropping. To prevent dropping, for example, permitted and correctly dimensioned support legs can be used.

If the machine is not secured against rolling away and lowering, serious or fatal accidents could result.

Runners

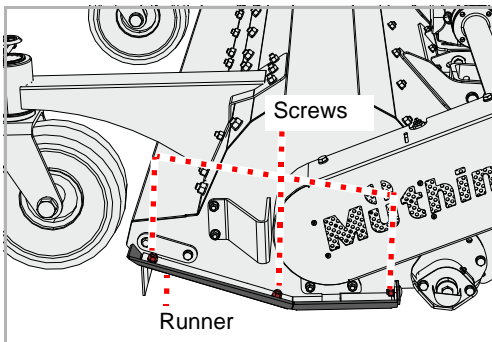

There are runners on the right-hand side and left-hand side.

- ▶ Undo nuts, remove screws and washers.
- ▶ Remove old runner
- ▶ Fit new runner
- ▶ Fit new screws and washers
- ▶ Secure screws with new nuts

If the runners also need to be replaced on the opposite side:

- ▶ Replace the runners on the opposite side as well.

Wear insert

A metal insert protects the housing from wear.

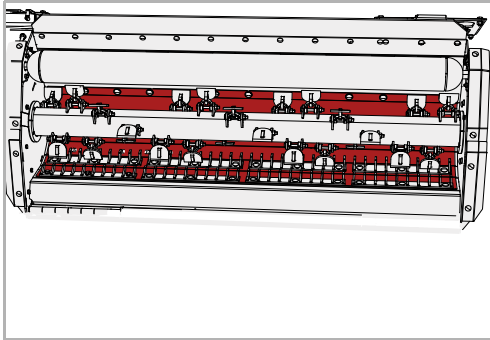

short-chopping bar

A second counter-cutter optimises the material feed. This produces better cutting. This produces better cutting.

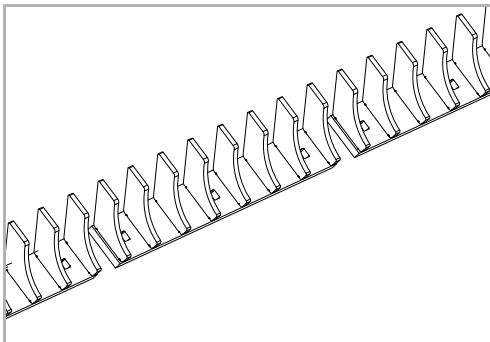

Support wheels

Support wheels are available for comfortable depth guidance.

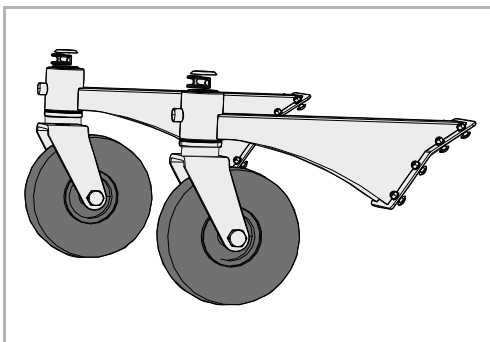

Operating hours counter

An electronic operating hours counter displays the actual operating duration. This means that data can be recorded precisely and used, for example, for calculations.

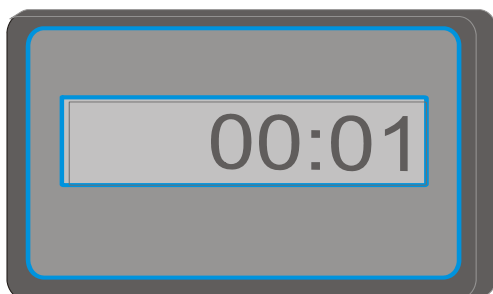

Fault elimination

Faults can often be eliminated quickly and easily. In the event of hydraulic problems, first check:

- Are the hydraulic hoses properly connected?
- Is the control valve on the carrier vehicle defective?
If so, contact your dealer.
- Is the hydraulic pump of the carrier vehicle defective?
If so, contact your dealer.

Before calling Customer Service, refer to the table below to check whether the fault is one you can eliminate yourself.

Fault	Cause	Remedy
Strong vibrations and high noise development	Tools are worn	Replace the tools
	One or more tools are missing	Replace tools
	Tools are damaged	Replace the tools
	Bearings for the rotor are worn	Have the bearings replaced
	Foreign bodies, such as wire, are wound around the rotor	Remove foreign bodies
	Tools have become loose	Tighten nuts on screws
	Speed of rotation of the PTO stub shaft is not set correctly	Set the correct speed of rotation on the PTO stub shaft
	Rotor not correctly counterbalanced	Check balancing and rebalance the rotor if necessary
Tools wearing quickly	The tools are working too deeply	Set correct working depth
Material cut too rough and cut material not distributed evenly	Drive speed too high	Reduce the drive speed
	The tools are working too deeply	Set correct working depth
	The tools are working too high	Set correct working depth
	V-belt worn	Replace V-belt set
	V-belt not correctly tensioned	Check V-belt tension and retension if necessary
	The speed of the PTO stub shaft of the carrier vehicle is too low.	Increase the rpm
	Tools are worn	Replace the tools
	The machine is not standing parallel to the ground	Adjust the machine correctly
Rotor does not turn	Rotor is blocked by a foreign body	Remove foreign bodies
	The PTO shaft is free-wheeling or the gear box is incorrectly assembled.	Have the free running state correctly assembled

Fault	Cause	Remedy
PTO shaft rotating, rotor is not	V-belt torn	Replace the V-belt
Unusual noises from the PTO shaft	Insufficient lubrication	Lubricate the PTO shaft
Gear box overheating	Incorrect oil specification	Change oil and select oil with correct specification
	Oil too old	Change oil
	Oil level too low	Fill the oil to the lower edge of the inspection opening
	Machine overload	Maintain rpm in correct region, adjust driving speed to suit the work, maintain performance area (avoid excessively heavy growth or excessively thick branches)
High wear on V-belts V-belts running hot Power transmission not optimal	The tools are working too deeply and touching the ground	Set correct working depth
	Pulleys not aligned in parallel	Have pulleys correctly aligned
	V-belt is worn	Replace the V-belt
	V-belt is not correctly tensioned	Check the tension jack
Oil leaking from the gear box	Sealing rings worn or damaged	Have sealing rings replaced
Drive elements broken	Machine was started up abruptly or is blocked by foreign bodies	Have defective drive element replaced. Start the machine up slowly.

Disposal of the machine

When the service life of your machine is over, it must be disposed of properly. Please observe currently valid disposal regulations.

Metal parts

All metal machine components can be sent for metal recycling.

Plastic parts

All plastic parts are marked and can be recycled.

Oil

Collect fluid from the hydraulic system in a suitable container and dispose of at a used oil collection facility.

EU-conformity declaration

EC Directive
2006/42/EG

Müthing GmbH & Co. KG Soest
Am Silberg 23
D-59494 Soest

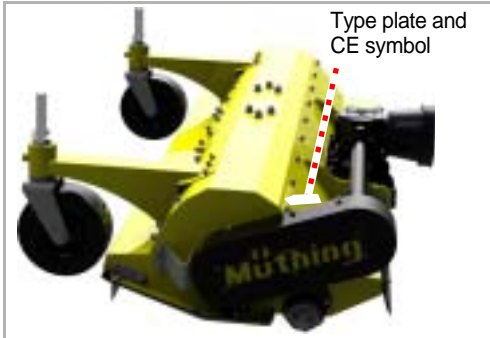

assumes sole responsibility for declaring that the following product complies with EC Directive 2006/42/EC:

MU-C and accessories

Assorted samples of harmonized standards:

- DIN EN ISO 4254-1
- DIN EN ISO 4254-12
- EN 13524

Soest, 28.10.2022

Andreas Rohde
CEO and authorised person for compiling technical documentation

Copy of the type plate/serial number entry

Machine type: Flail mower

Model:

Working width:

Serial number:

Year of construction:

EU-conformity declaration

EC Directive
2006/42/EG

Müthing GmbH & Co. KG Soest
Am Silberg 23
D-59494 Soest

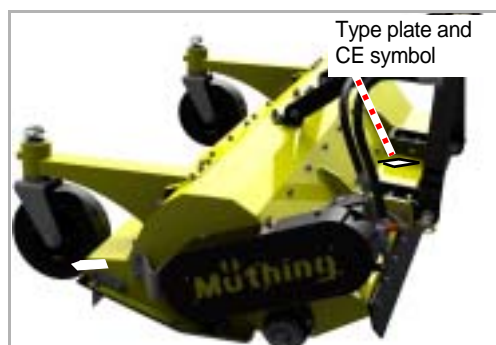

assumes sole responsibility for declaring that the following product complies with EC Directive 2006/42/EC:

MU-C Hydro and additional equipment

Assorted samples of harmonized standards:

- DIN EN ISO 4254-1
- DIN EN ISO 4254-12
- EN 13524

Soest, 28.10.2022

Andreas Rohde
CEO and authorised person for compiling technical documentation

Copy of the type plate/serial number entry

Machine type:	Flail mower
Model:	
Working width:	
Serial number:	
Year of construction:	

UK Declaration of Conformity

UKCA

Müthing GmbH & Co. KG Soest
Am Silberg 23
D-59494 Soest
Germany

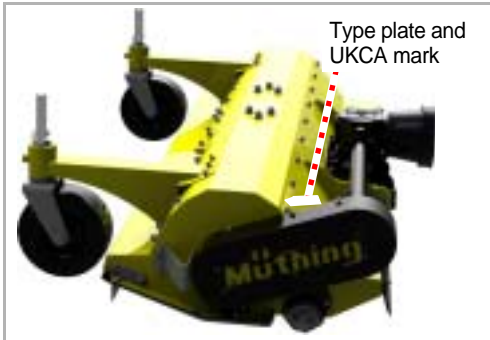

declares under sole responsibility that the machine conforms with the following directives:

- Supply of Machinery (Safety) Regulations 2008

Assorted samples of harmonized standards:

- BS EN ISO 4254-1
- BS EN ISO 4254-12
- BS EN 13524

Machine designation	MU-C and additional equipment
---------------------	-------------------------------

The special technical documents corresponding to the machine have been created according to Annex VII, Part B.

Soest, 28.10.2022

Andreas Rohde
CEO and authorised person for compiling technical documentation

Copy of the type plate/serial number entry

Type of machine:	Mulcher
Model:	
Working Width:	
Machine ID:	
Production Year:	

UK Declaration of Conformity

UKCA

Müthing GmbH & Co. KG Soest
Am Silberg 23
D-59494 Soest
Germany



declares under sole responsibility that the machine conforms with the following directives:

- Supply of Machinery (Safety) Regulations 2008

Assorted samples of harmonized standards:

- BS EN ISO 4254-1
- BS EN ISO 4254-12
- BS EN 13524

Machine designation

MU-C Hydro and additional equipment

The special technical documents corresponding to the machine have been created according to Annex VII, Part B.

Soest, 28.10.2022

Andreas Rohde

CEO and authorised person for compiling technical documentation

Copy of the type plate/serial number entry

Type of machine: Mulcher

Model:

Working Width:

Machine ID:

Production Year:

A			
Accessory	59		
Operating hours counter	59		
short-chopping bar	59		
Support wheels	59		
Wear insert	59		
assembly	23		
C			
Care	41		
Centre of gravity	15		
Cleaning	41		
Coupling	32		
D			
Direction information	13		
E			
Employer	8		
F			
Fault	60		
Features	22		
I			
Instruction	8		
L			
labels, see warning signs			
Lubricate bearings	49		
M			
Machine			
Storing	43		
Maintenance			
General information	45		
Maintenance intervals	48		
Overview of lubrication points	50		
Safety	44		
P			
Parking	42		
Pictograms	9		
Protective procedure			
Oils or lubricants	45		
R			
Range of application	21		
Carbide M shackle flails	21		
S			
Safety	10		
Agricultural training	13		
Altered driving and braking behaviour	17		
Care and maintenance intervals	19		
Care and maintenance work	19		
Centre of gravity	15		
Check the screwed connections	20		
Cleaning	20		
Coupling	14		
Proper use	21		
Putting the machine into operation	17		
Riding on the machine	17		
Total weight	15		
Uncoupling the machine	19		
Warning signs	10		
Welding work	20		
Scope of delivery	28		
Screwed connections	47		
Setting down the machine in a secure position	42		
Symbols	9		
T			
Target group	8		
Task	38		
Technical specifications	25		
Tightening torques			
General	47		
Transport			
Transport position	37		
Transport without coupling	37		
Transport without coupling	37		
W			
Warning signs	10		
Meaning	11		
Working width	36		