

ERSATZTEILLISTE | Spare parts list

Liste des pièces de rechange | Lista de repuestos

MU-E-H VARIO 120 - 200

AB SERIE | as of series | á partir de série | desde de la serie 2016

AUSGABE | edition | version | edición 11.2019

BESTELLCODE | Order code | Code de commande | Código de pedido P_E_FT_16_WEL_HE

Übertragen Sie hier bitte die Daten Ihres Gerätes und des verwendeten Getriebes.

Enter the details for your implement and the gear box you are using here.

Veuillez inscrire ici les références de votre machine et celles du boîtier.

Introduzca aquí los datos de su equipo y la transmisión utilizada.



*Beispiel Typenschild | Type plate example
Exemple de plaque signalétique | Ejemplo de una placa de características*

Benennung Designation Désignation Designación	Eintrag Entry N° d'enregistrement Registro
Modell Model Modèle Modelo	MU-E-H VARIO 120 - 200 <input type="checkbox"/> 120 <input type="checkbox"/> 140 <input type="checkbox"/> 160 <input type="checkbox"/> 180 <input type="checkbox"/> 200
Seriennummer Serial number N° de série Número de serie	
Baujahr Year of manufacture Année de construction Año de construcción	
Getriebetyp Gearbox type Type de Système d'entraînement Tipo de transmisión	
Anbaubock Headstock Attelage Soporte adosado	<input type="checkbox"/> fest fixed fixe fijo <input type="checkbox"/> verschiebbar movable déportable móvil
Händler Dealer Distributeur Concesionario	
Inbetriebnahme am Date commissioned Date de mise en service Fecha de puesta en servicio	

Bei bitte deutlich ankreuzen !

Where there are checkboxes , please check these clearly!

Veuillez cocher les cases lisiblement!

Por favor, marque con una cruz en la casilla .



Blank page with horizontal dotted lines for writing.



Einleitung Introduction Introduction Introducción 	6
Gerätebeschreibung Device description Description de l'appareil Description del dispositivo 	7
Grundausführung Basic model Modèle de base Modelo básico 	
Gehäuse Housing Caisson Caja 	8
Anbaubock - Heck Headstock - rear Attelage - arrière Soporte adosado - popa 	14
Antrieb & Getriebe Drive and gear box Transmission et Système d'entraînement Accionamiento e Cambio 	18
Übersetzung Getriebe Gear box translation Système d'entraînement multiplication Cambio la traducción 	22
Schäkelrotor Shackle rotor Rotor manilles Grillete rotor 	24
Stützwalze Support roller Rouleau d'appui Cilindro de apoyo 	28
Getriebe Gear box Système d'entraînement Cambio 	32
Sonderzubehör Optional accessory Accessoires optionnels Componente especial 	
Gelenkwelle - GE2301 Cardan shaft - GE2301 Arbre de transmissio - GE2301 Árbol de transmisión - GE2301 	36
Kurzschnittklappe Short -cut flap Clapet de coupe courte Tapa de corte corto 	38
Kurzhäckselleiste Short chopping bar Lame hache-paille courte Listón de corte de paja corto 	40
Hydraulische Seitenverschiebung Hydraulic side shift Déport latéral hydraulique Desplazamiento lateral hidráulico 	42
Schneidschiene Cutting bar Contre-Lame Réglable Carril de corte 	46
Verschleißeinlage Wear insert Blindage Junta de desgaste 	48
Verschleißkufen Wear runner Patin d' usure Cuchilla de desgaste 	50
Betriebsstundenzähler Operating hours counter Compteur horaire Contador de horas de servicio 	52
Beleuchtungsträger Lighting equipment Support d' éclairage Soporte de alumbrado 	54
Warntafel mit Beleuchtungseinrichtung Warning sign with lighting equipment Panneau de signalisation avec système d' éclairage Panel de aviso con dispositivo de iluminación 	56
Kontakte Contacts Contacts Contactos 	
National Nactional National Nacional 	58
International Internactional Internationale Internationalmente 	60

20 horizontal dotted lines for writing.





SEHR GEEHRTER KUNDE,

auf den folgenden Seiten finden Sie eine vollständige Übersicht aller Bauteile Ihres Müthing Mulchgerätes MU-E-H VARIO 120 - 200. Anhand dieser Unterlage bitten wir Sie benötigte Ersatzteile genau zu identifizieren und mit den nachfolgenden Angaben zu bestellen. Benötigen Sie Hilfe oder weitere Informationen kontaktieren Sie uns.

Vielen Dank - Ihr Müthing-Team

CHER CLIENT,

Vous trouverez sur les pages suivantes une description complète des composants de votre broyeur Müthing MU-E-H VARIO 120 - 200. Nous vous invitons à identifier exactement les pièces de rechange requises à l'appui de ce document et de les commander en indiquant le n° de référence de pièces de rechange. N'hésitez pas à nous contacter si vous avez besoin d'aide ou d'informations complémentaires.

Merci beaucoup – Votre équipe Müthing

DEAR CUSTOMER,

The following pages offer a complete overview of the components in your Müthing MU-E-H VARIO 120 - 200 mulcher. We are providing you with this document so that you can identify exactly the spare parts you require and order them using the spare part numbers listed. Should you need any assistance or further information, please contact us.

Kind regards - Your Müthing team

ESTIMADO CLIENTE,

En las siguientes páginas ponemos a su disposición una relación completa de los componentes de su trituradora MU-E-H VARIO 120 - 200 de Müthing. Le rogamos que con ayuda de este listado identifique las piezas de repuesto necesarias y las encargue con su correspondiente número de repuesto. No dude en ponerse en contacto con nosotros para solicitar ayuda o información ampliada.

Muchas gracias - Su equipo Müthing



Beachten Sie immer die Sicherheitshinweise der Betriebsanleitung !

Always follow the safety instructions in the operating manual.

Veillez toujours tenir compte des consignes de sécurité figurant dans le manuel d'utilisation !

Observe siempre las indicaciones de seguridad de las instrucciones de servicio !

DIE HAUPTBAUGRUPPEN SIND:

1. Dreipunktanbaubock (fest oder verschiebbar)
2. Mulchergehäuse mit Schutzlamellen, hinterem Gummischutz und Gleitkufen
3. Rotor mit Lagerung, Werkzeugen und Werkzeughaltern
4. Stützwalze (Stützräder) mit Lagerung
5. Keilriemenantrieb mit Keilriemenschutzhaube
6. Getriebe
7. Gelenkwelle (Explosionszeichnung)
8. Sonderzubehör

THE MAIN COMPONENTS ARE:

1. Three-point headstock (fixed or movable)
2. Mulcher housing with protective strips, rear rubber protector and skids
3. Rotor with mount, tools and tool holders
4. Support roller (support wheels) with mount
5. V-belt drive with V-belt guard
6. Gear box
7. PTO shaft (exploded view)
8. Optional accessories

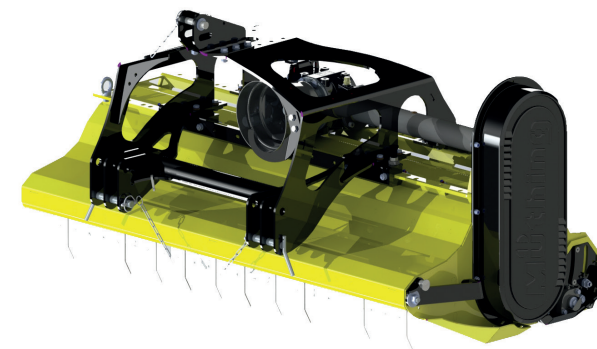

LES GROUPES PRINCIPAUX SONT:

1. Attelage trois points (déport latéral possible)
2. Carter du broyeur avec lamelles de protection, protection en caoutchouc à l'arrière et patins de glissement
3. Rotor équilibré avec outils et supports d'outils
4. Rouleau d'appui (roue palpeuse) avec suspension
5. Transmission par courroie trapézoïdale avec capot de protection
6. Système d'entraînement
7. Arbre de transmission (vue éclatée)
8. Accessoires spécifiques

LOS GRUPOS CONSTRUCTIVOS PRINCIPALES SON:

1. Enganche de tres puntos (fijo o desplazable)
2. Carcasa de la trituradora con placas de protección, protección trasera de goma y patines
3. Rotor con cojinete, herramientas y portaherramientas
4. Cilindro de apoyo (ruedas de apoyo) con cojinete
5. Accionamiento por correa trapezoidal con cubierta protectora de la correa
6. Transmisión
7. Árbol de transmisión (plano explosionado)
8. Accesorio especial

| Hauptbaugruppe Schlegelmulcher Baureihe MU-E-H VARIO 120 - 200
| Main assembly of the MU-E-H VARIO 120 - 200 flail mulcher
| Groupe principal broyeur à marteaux série MU-E-H VARIO 120 - 200
| Grupo constructivo desbrozadora serie MU-E-H VARIO 120 - 200

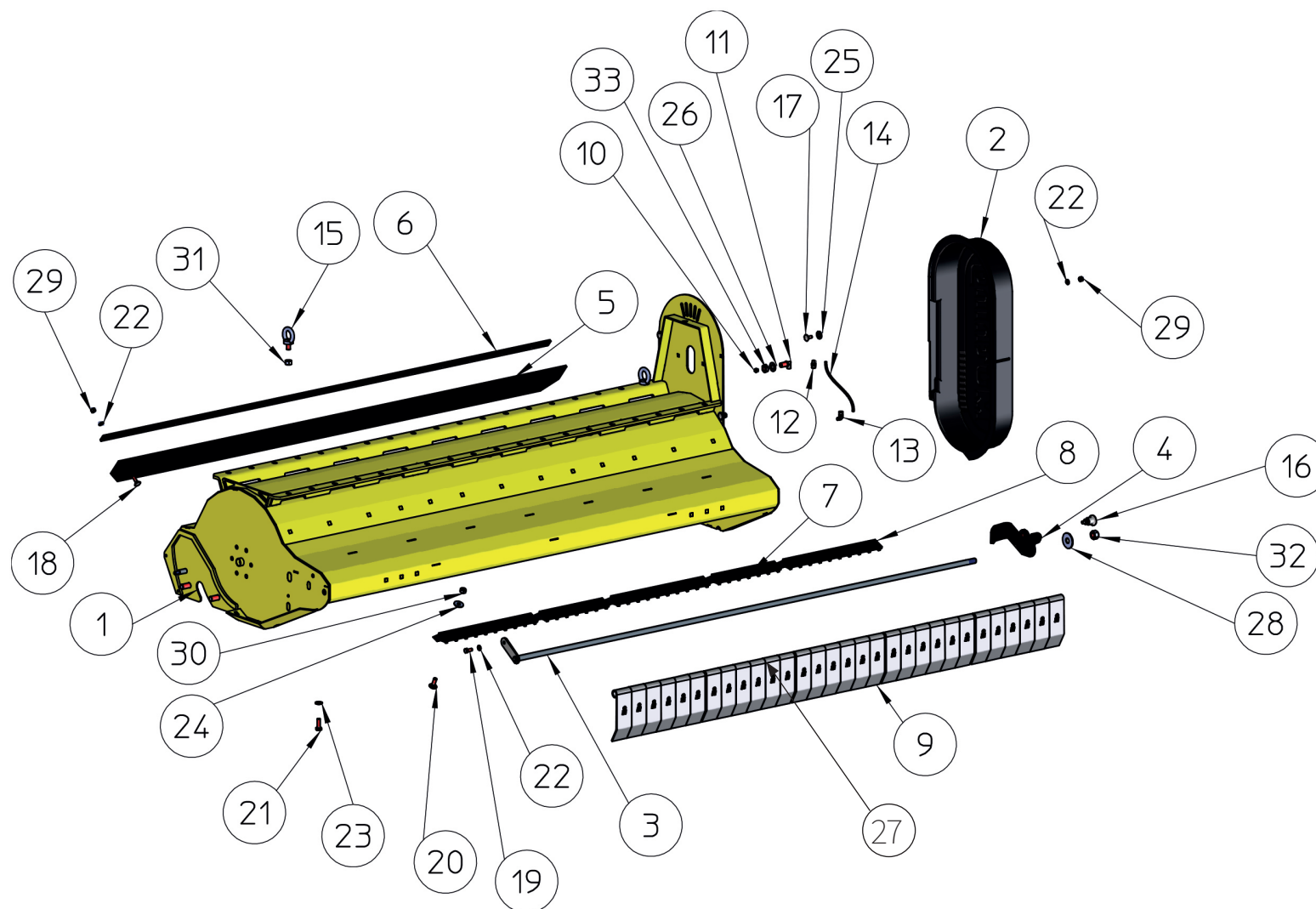

Pos.-Nr. No. Número	Ersatzteilnummer Manufacturer part number Numéro d'article du fabricant Número de pieza del fabricante					DE Bezeichnung	EN Designation	FR Désignation	ES Designación
	Anzahl quantity quantité número								
	MU-E 120	MU-E 140	MU-E 160	MU-E 180	MU-E 200				
1	00017413 1	00017378 1	00017366 1	00017345 1	00015260 1	Gehäuse	housing	Caisson	Caja
2	1	1	00017110 1	1	1	Schutz- abdeckung	protective cover	Recouvrement de protection	Cubierta protectora
3	00017415 1	00017380 1	00017173 1	00017347 1	00017112 1	Pendelwelle	swing shaft	Arbre oscillant	Eje del péndulo
4	1	1	00017060 1	1	1	Stütze	pillar	Support	Apoyo
5	00003530 1	00003524 1	00003519 1	00017348 1	00015266 1	Schutzgummi	guard	Protection	Protección
6	00003529 1	00003523 1	00003518 1	00017338 1	00015244 1	Halteblech	support plate	Tôle de support	Bloque de terminales
7	-	2	00005516 0	2	-	Gegenschneide 300	chopping bars	Lame hache-paille courte	Listón de corte de paja corto
8	3	2	00005518 4	3	5	Gegenschneide 400	chopping bars	Lame hache-paille courte	Listón de corte de paja corto
9	20	23	MU000313-1 26	30	33	Pendelklappen	flap with swing protection	Volvet de protection	Tapa protecto del puéndulo
10	2	2	H1 M08x1 2	2	2	Schmiernippel	lubricating nipple	Nipple de graissage	Engrasador



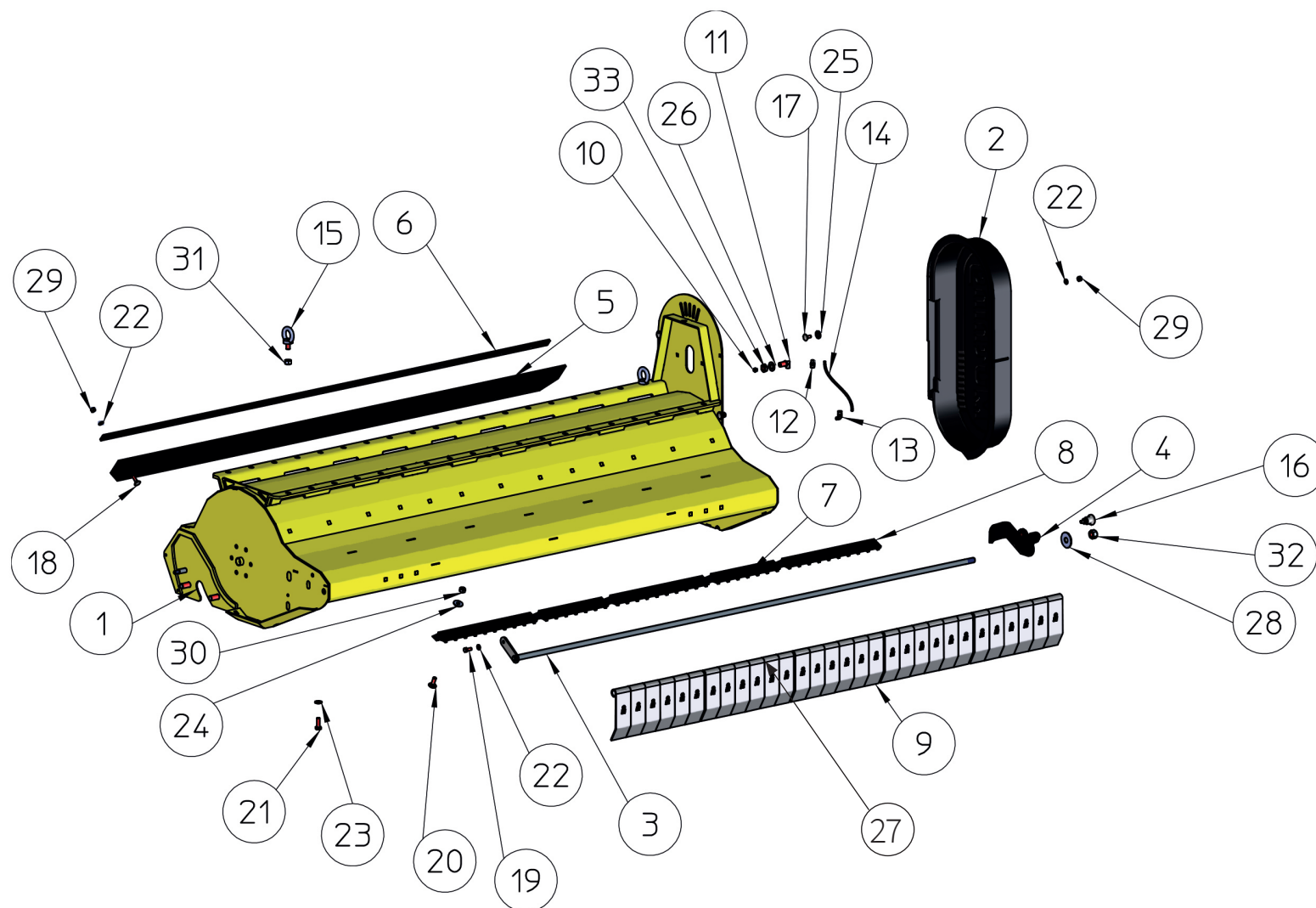

Pos.-Nr. No. Número	Ersatzteilnummer Manufacturer part number Numéro d'article du fabricant Número de pieza del fabricante					DE Bezeichnung	EN Designation	FR Désignation	ES Designación
	Anzahl quantity quantité número								
	MU-E 120	MU-E 140	MU-E 160	MU-E 180	MU-E 200				
11	1	1	00017522 1	1	1	Rohrverbinder	connector	Conector	Connecteur
12	1	1	MULI0002 1	1	1	Verschraubung	Screwed connection	Raccord à vis	Atornillamiento
13	1	1	MULI0006 1	1	1	Verschraubung	Screwed connection	Raccord à vis	Atornillamiento
14	0,25m	0,25m	MULI0005 0,25m	0,25m	0,25m	Schmierleitung	lubrication line	Conduite de graissage	Tubería de engrase
15	2	2	00008092A 2	2	2	Schraube	bolt	Vis	Tornillo
16	1	1	00017113 1	1	1	Rastriegel	catch lock	boulon de verrouillage	pasador de retención
17	3	3	MU980107 3	3	3	Schraube	bolt	Vis	Tornillo
18	9	11	MU0099987 13	13	15	Schraube	bolt	Vis	Tornillo
19	1	1	MU0099972 1	1	1	Schraube	bolt	Vis	Tornillo
20	9	10	00000904 12	13	15	Schraube	bolt	Vis	Tornillo
21	11	13	MU980205 17	19	21	Schraube	bolt	Vis	Tornillo
22	15	17	MU0099999 19	19	21	Scheibe	washer	Disque	Arandela
23	11	13	MUNSKL10 17	19	21	Scheibe	washer	Disque	Arandela
24	9	10	MU0099950 12	13	15	Scheibe	washer	Disque	Arandela

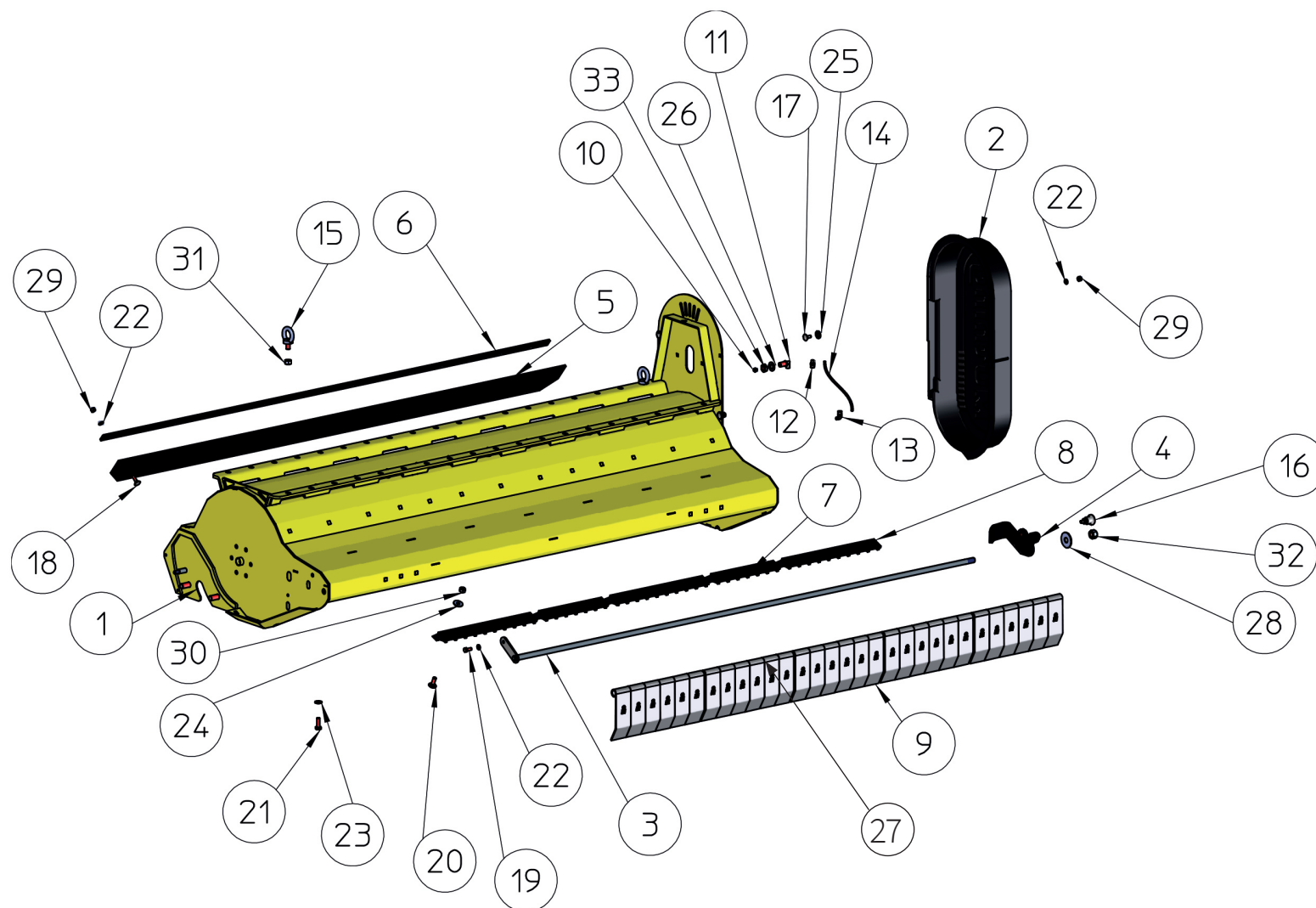

Pos.-Nr. No. Numéro Número	Ersatzteilnummer manufacturer Part number Numéro d'article du fabricant Número de pieza del fabricante					DE Bezeichnung	EN Designation	FR Désignation	ES Designación
	Anzahl quantity quantité número								
	MU-E 120	MU-E 140	MU-E 160	MU-E 180	MU-E 200				
25	MU0099997					Scheibe	washer	Disque	Arandela
	3	3	3	3	3				
26	MU980502					Scheibe	washer	Disque	Arandela
	1	1	1	1	1				
27	MU980402					Scheibe	bolt	Vis	Tornillo
	4	10	15	2	8				
28	MU980403					Scheibe	bolt	Vis	Tornillo
	1	1	1	1	1				
29	MU0099961					Mutter	nut	Écrou	Tuerca
	14	16	18	18	20				
30	MU0099960					Mutter	nut	Écrou	Tuerca
	9	10	12	13	15				
31	MU980301					Mutter	nut	Écrou	Tuerca
	2	2	2	2	2				
32	MU980401					Mutter	nut	Écrou	Tuerca
	1	1	1	1	1				
33	MU980521					Mutter	nut	Écrou	Tuerca
	1	1	1	1	1				



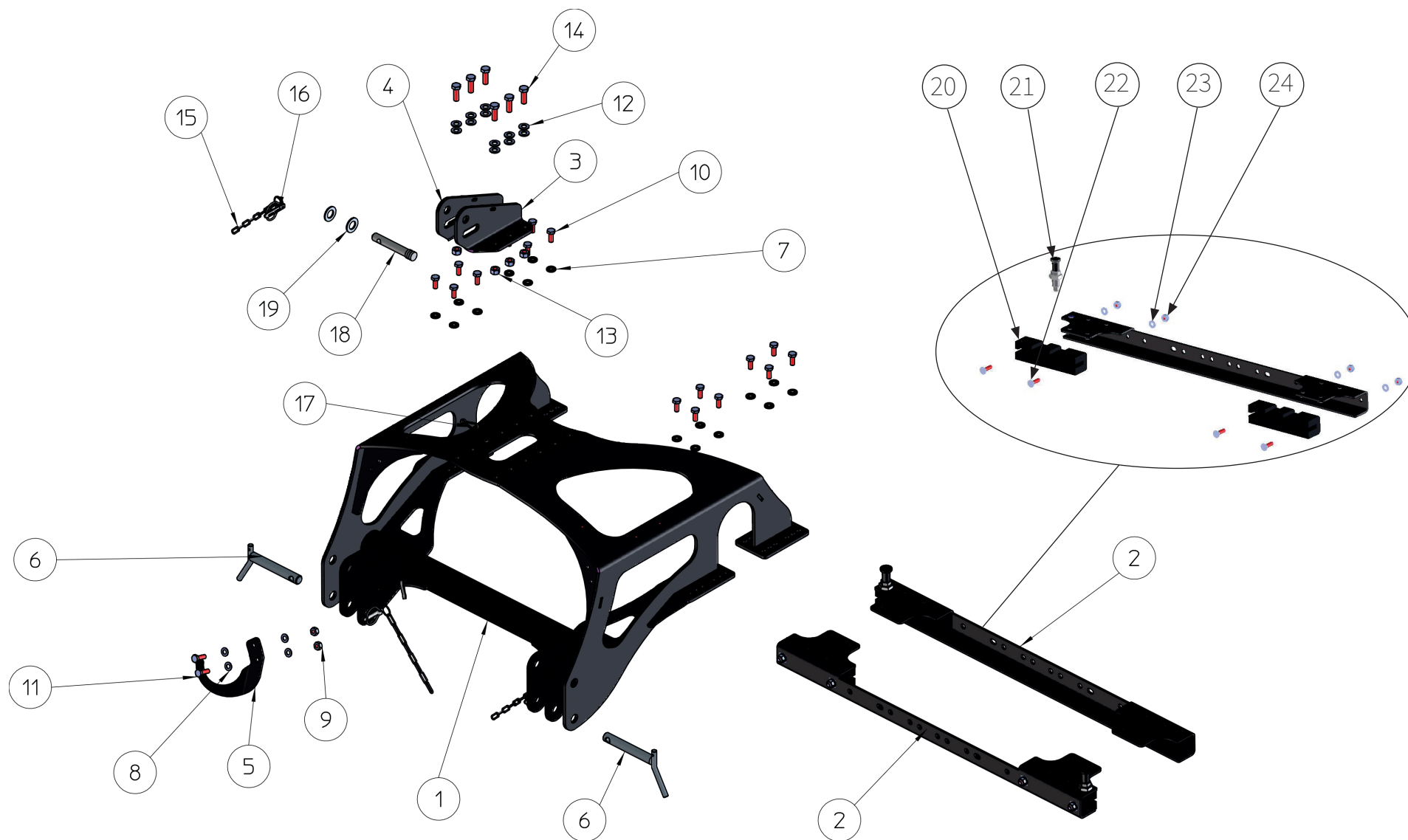

Pos.-Nr. No. Número	Ersatzteilnummer Manufacturer part number Numéro d'article du fabricant Número de pieza del fabricante					DE Bezeichnung	EN Designation	FR Désignation	ES Designación
	Anzahl quantity quantité número								
	MU-E 120	MU-E 140	MU-E 160	MU-E 180	MU-E 200				
1	1	1	00015862 1	1	1	Anbaubock	headstock	Attelage	Soporte adosado
2	2	2	00015847 2	2	2	Gleitschienen- aufnahme klp.	slide bar - holder	Rail de glissement - Logement	Riel de deslizamien- to - Alojamiento
3	1	1	00015863 1	1	1	Oberlenker- aufnahme	upper link receiver	Logement du bras supérieur	Alojamiento del brazo superior
4	1	1	00015864 1	1	1	Oberlenker- aufnahme	upper link receiver	Logement du bras supérieur	Alojamiento del brazo superior
5	1	1	00015843 1	1	1	Gelenkwellen- halter	PTO shaft holder	Support d'arbre á cardan	Soporte del árbol articulado
6	2	2	MU0010871 2	2	2	Unterlenkerbolzen	pin	Axe	Perno
7	16	16	MUNSKL10 16	16	16	Scheibe	washer	Disque	Arandela
8	4	4	MU0099998 4	4	4	Scheibe	washer	Disque	Arandela
9	2	2	MU0099960 2	2	2	Mutter	nut	Écrou	Tuerca
10	16	16	MU980208 16	16	16	Schraube	bolt	Vis	Tornillo
11	2	2	MU980205 2	2	2	Schraube	bolt	Vis	Tornillo
12	12	12	MU0099997 12	12	12	Scheibe	washer	Disque	Arandela
13	6	6	MU980301 6	6	6	Mutter	nut	Écrou	Tuerca
14	6	6	MU980311 6	6	6	Schraube	bolt	Vis	Tornillo

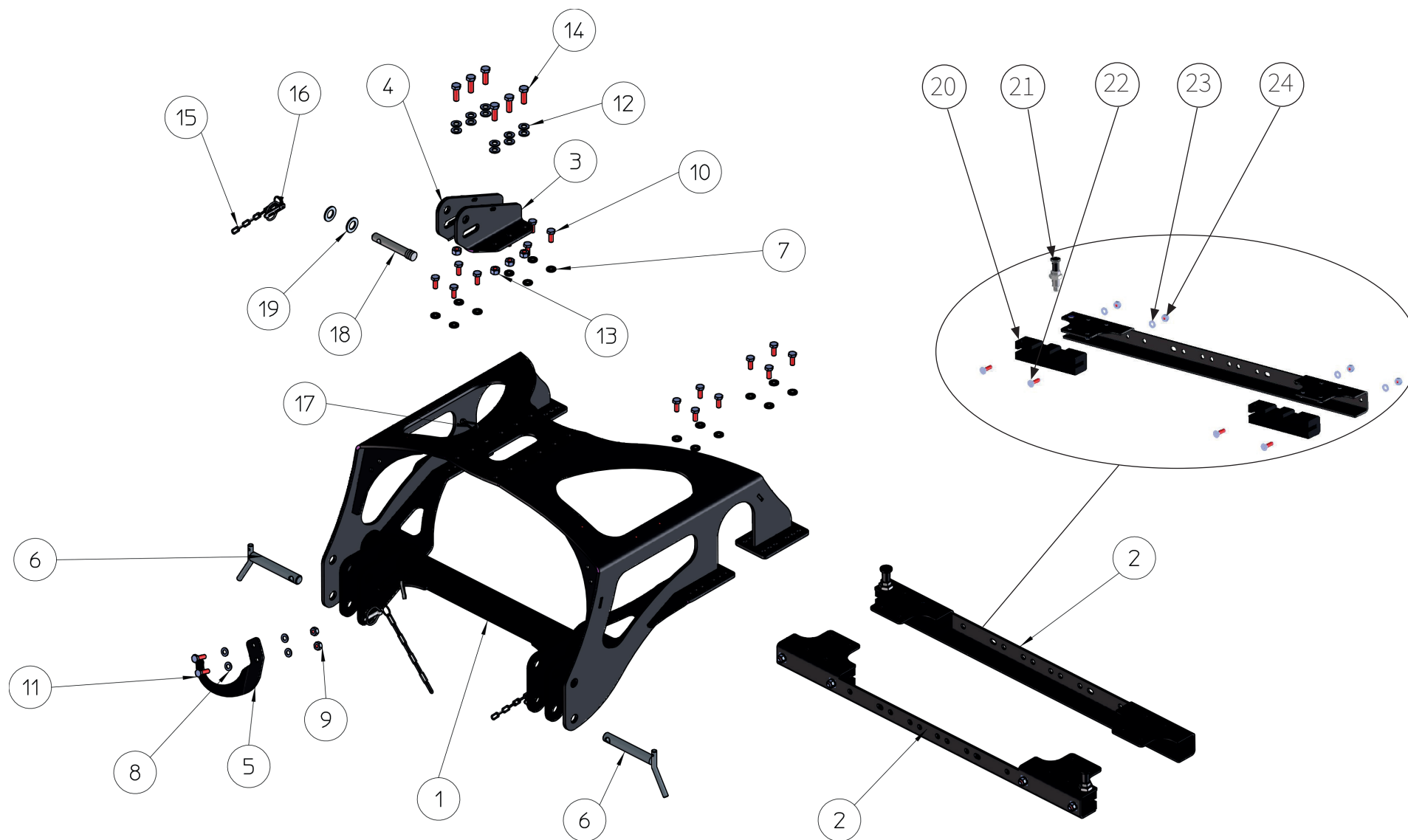

Pos.-Nr. No. Numéro Número	Ersatzteilnummer Manufacturer part number Numéro d'article du fabricant Número de pieza del fabricante					DE Bezeichnung	EN Designation	FR Désignation	ES Designación
	Anzahl quantity quantité número								
	MU-E 120	MU-E 140	MU-E 160	MU-E 180	MU-E 200				
15	3	3	00017524 3	3	3	Sicherungskette	chain	Chaine	Cadena
16	3	3	00017525 3	3	3	Sicherungsklapp- stecker	lynch pin	Esse d'essieu	Pasador abatible
17	3	3	00017526 3	3	3	Simplexhaken	securing hook	Crochet de sécurité	Gancho de retención
18	1	1	MAZ 081110 1	1	1	Oberlenkerbolzen	pin	Axe	Perno
19	2	2	MU980505 2	2	2	Scheibe	washer	Disque	Arandela
20	2	2	00015846 2	2	2	Gleitplatte	slide plate	Rail de glissement	Placa deslizante
21	1	1	00015865 1	1	1	Rastbolzen	stop bolt	Boulon d'arrêt	Perno de retención
22	4	4	MU980251 4	4	4	Schraube	bolt	Vis	Tornillo
23	4	4	MU980202 4	4	4	Scheibe	washer	Disque	Arandela
24	4	4	MU0099960 4	4	4	Mutter	nut	Écrou	Tuerca



Eine detaillierte Explosionskizze des Getriebes finden Sie auf den folgenden Seiten.

A detailed exploded view of the gear box can be found on the following pages.

Vous trouverez un schéma éclaté détaillé du boîtier sur les pages suivantes.

En las siguientes páginas también se incluye un diagrama de vista explotada de la transmisión.

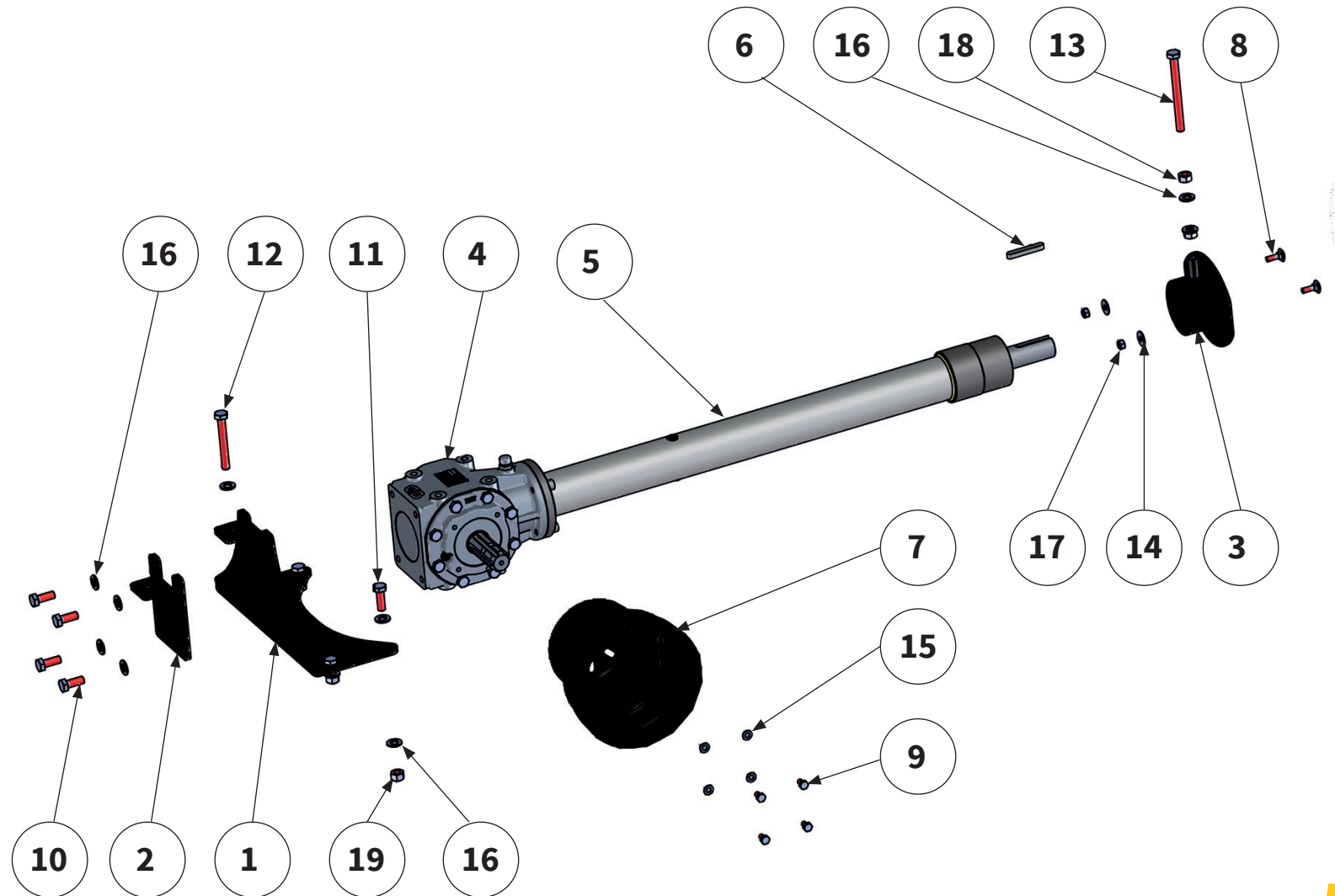

Pos.-Nr. No. Número	Ersatzteilnummer Manufacturer part number Numéro d'article du fabricant Número de pieza del fabricante					DE Bezeichnung	EN Designation	FR Désignation	ES Designación
	Anzahl quantity quantité número								
	MU-E 120	MU-E 140	MU-E 160	MU-E 180	MU-E 200				
1	00015289					Getriebehalterung	gear box holder	Support de transmission	Soporte del cambio
	1	1	1	1	1				
2	00015290					Getriebehalter	gear box holder	Support de transmission	Soporte del cambio
	1	1	1	1	1				
3	00015293					Spannvorrichtung	clamping device	Dispositif de serrage	Dispositivo de sujeción
	1	1	1	1	1				
4	MU980831 MU980831-BRM					Getriebe	gear box	Système d'entraînement	Cambio
	1	1	1	1	1				
5	MU980841	MU0010063	MU980834	MU0010065		Verlängerungswelle	extension shaft	Arbre de rallonge	Eje de prolongación
	1	1	1	1	1				
6	MU981900					Passfeder	parallel key	Clavette	Chaveta de ajuste
	1	1	1	1	1				
7	MU1510160					Schutztopf	protective pot	Barillet de protection	Tapa de protección
	1	1	1	1	1				
8	MU0099988					Schraube	bolt	Vis	Tornillo
	2	2	2	2	2				
9	MU980159					Schraube	bolt	Vis	Tornillo
	4	4	4	4	4				
10	MU980307					Schraube	bolt	Vis	Tornillo
	4	4	4	4	4				
11	MU980311					Schraube	bolt	Vis	Tornillo
	4	4	4	4	4				
12	MU980316					Schraube	bolt	Vis	Tornillo
	1	1	1	1	1				
13	MU981901					Schraube	bolt	Vis	Tornillo
	1	1	1	1	1				

Eine detaillierte Explosionskizze des Getriebes finden Sie auf den folgenden Seiten.

A detailed exploded view of the gear box can be found on the following pages.

Vous trouverez un schéma éclaté détaillé du boîtier sur les pages suivantes.

En las siguientes páginas también se incluye un diagrama de vista explotada de la transmisión.

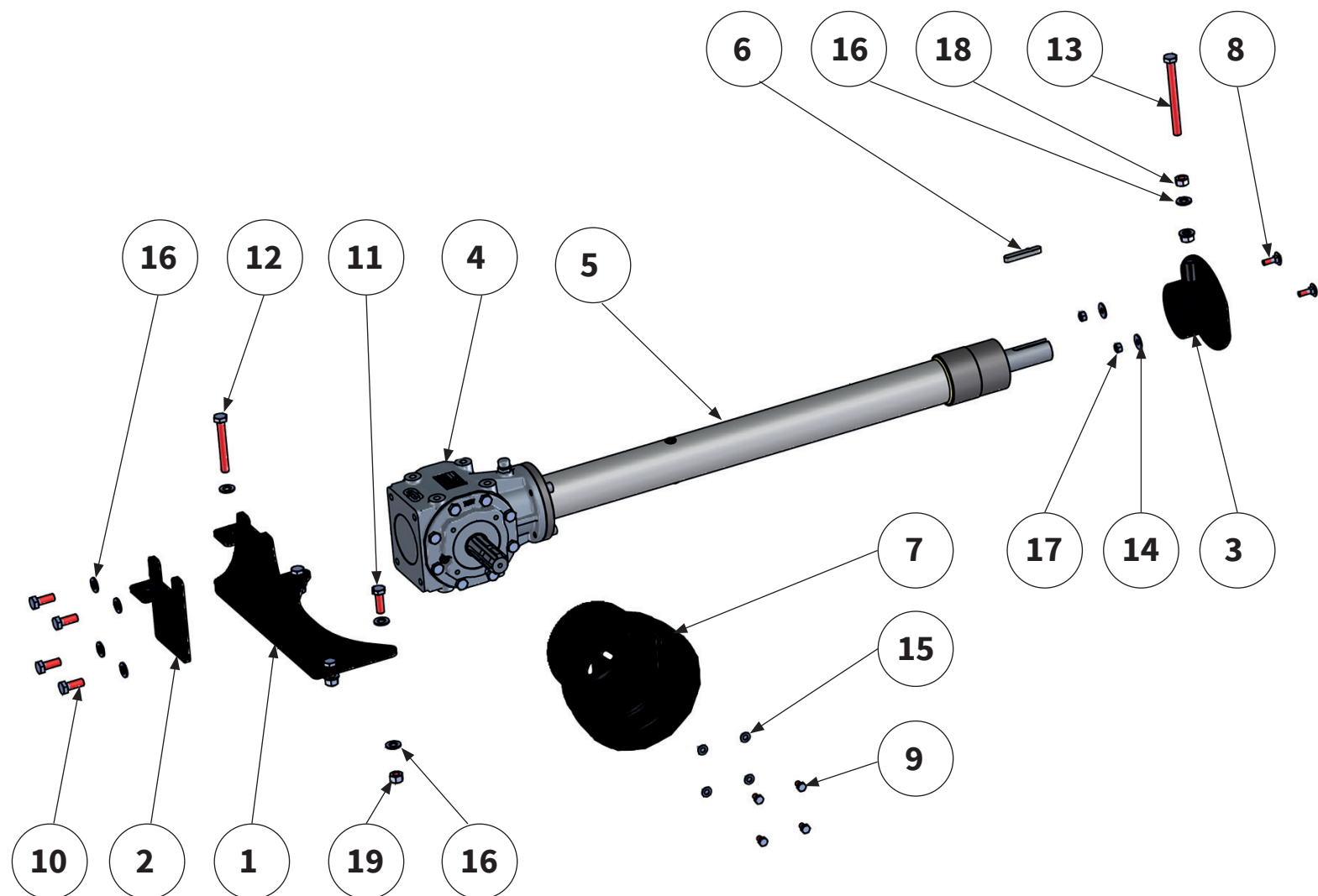

Pos.-Nr. No. Numéro Número	Ersatzteilnummer Manufacturer part number Numéro d'article du fabricant Número de pieza del fabricante					DE Bezeichnung	EN Designation	FR Désignation	ES Designación
	Anzahl quantity quantité número								
	MU-E 120	MU-E 140	MU-E 160	MU-E 180	MU-E 200				
14	MU0099951					Scheibe	washer	Disque	Arandela
	2	2	2	2	2				
15	MU980102					Scheibe	washer	Disque	Arandela
	4	4	4	4	4				
16	MU980302					Scheibe	washer	Disque	Arandela
	15	15	15	15	15				
17	MU0099961					Mutter	nut	Écrou	Tuerca
	2	2	2	2	2				
18	MU0099932					Mutter	nut	Écrou	Tuerca
	2	2	2	2	2				
19	MU980301					Mutter	nut	Écrou	Tuerca
	4	4	4	4	4				



Getriebe-Eingangsdrehzahl | Input speed
 Vitesse d'entrée | Velocidad entrada | **540 U / min -1**

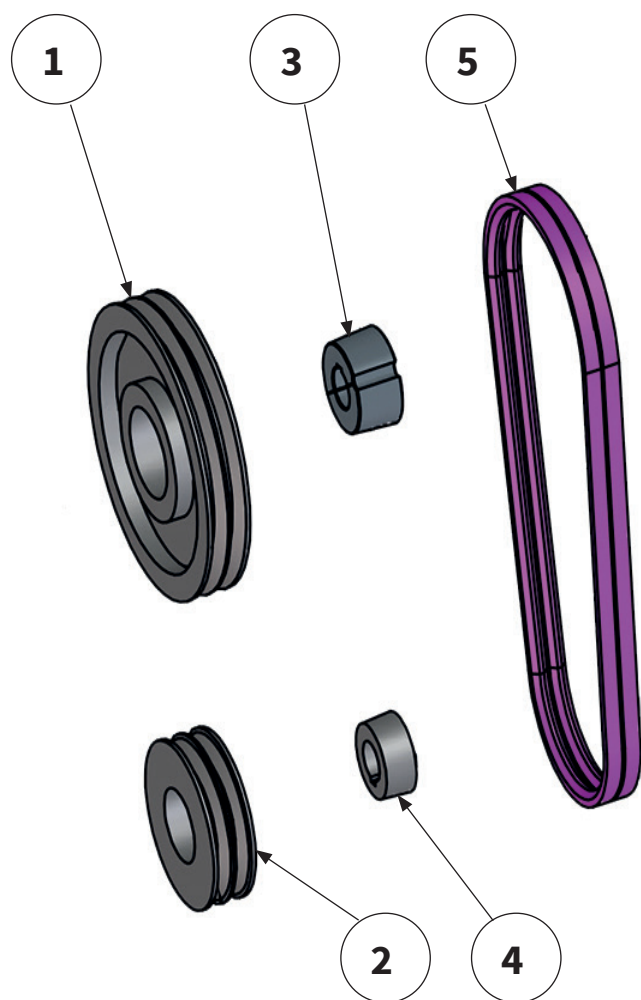

Getriebe-Eingangsdrehzahl | Input speed
 Vitesse d'entrée | Velocidad entrada | **1000 U / min -1**

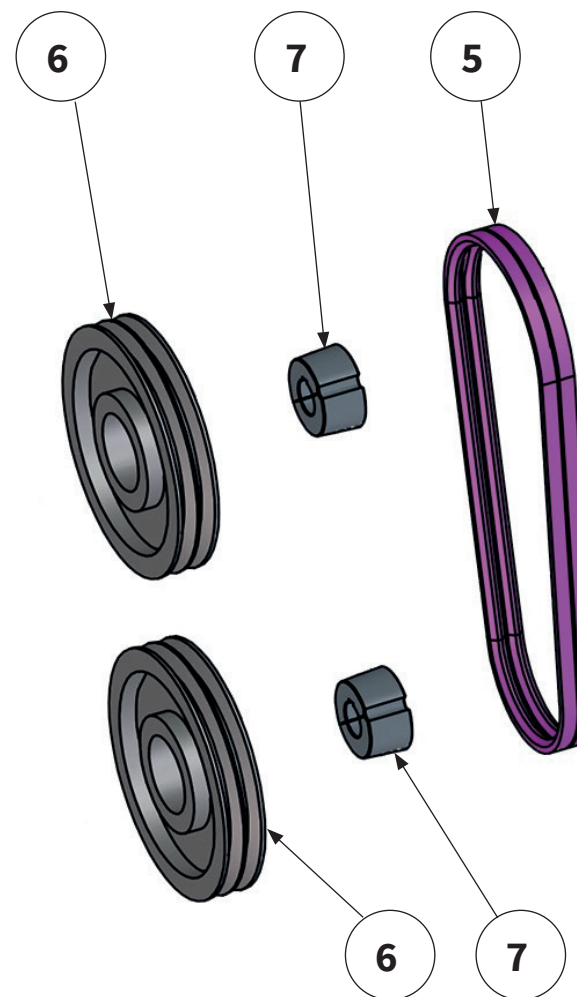

Pos.-Nr. No. Número Número	Ersatzteilnummer Manufacturer part number Numéro d'article du fabricant Número de pieza del fabricante					DE Bezeichnung	EN Designation	FR Désignation	ES Designación
	Anzahl quantity quantité número								
	MU-E 120	MU-E 140	MU-E 160	MU-E 180	MU-E 200				
1	1	1	00005572 1	1	1	Keilriemenscheibe	V-belt pulley	Poulie	Polea
2	1	1	00017115 1	1	1	Keilriemenscheibe	V-belt pulley	Poulie	Polea
3	1	1	MU980829 1	1	1	Taperspann- buchse	clamping bush	Douille de serrage	Manguito de sujeción
4	1	1	00005570 1	1	1	Taperspann- buchse	clamping bush	Douille de serrage	Manguito de sujeción
5	2	2	MU980827 2	2	2	Keilriemen	V-belt	Courroie trapézoïdale	Correa trapezoidal
6	2	2	MU981911 2	2	2	Keilriemenscheibe	V-belt pulley	Poulie	Polea
7	2	2	MU980829 2	2	2	Taperspann- buchse	clamping bush	Douille de serrage	Manguito de sujeción



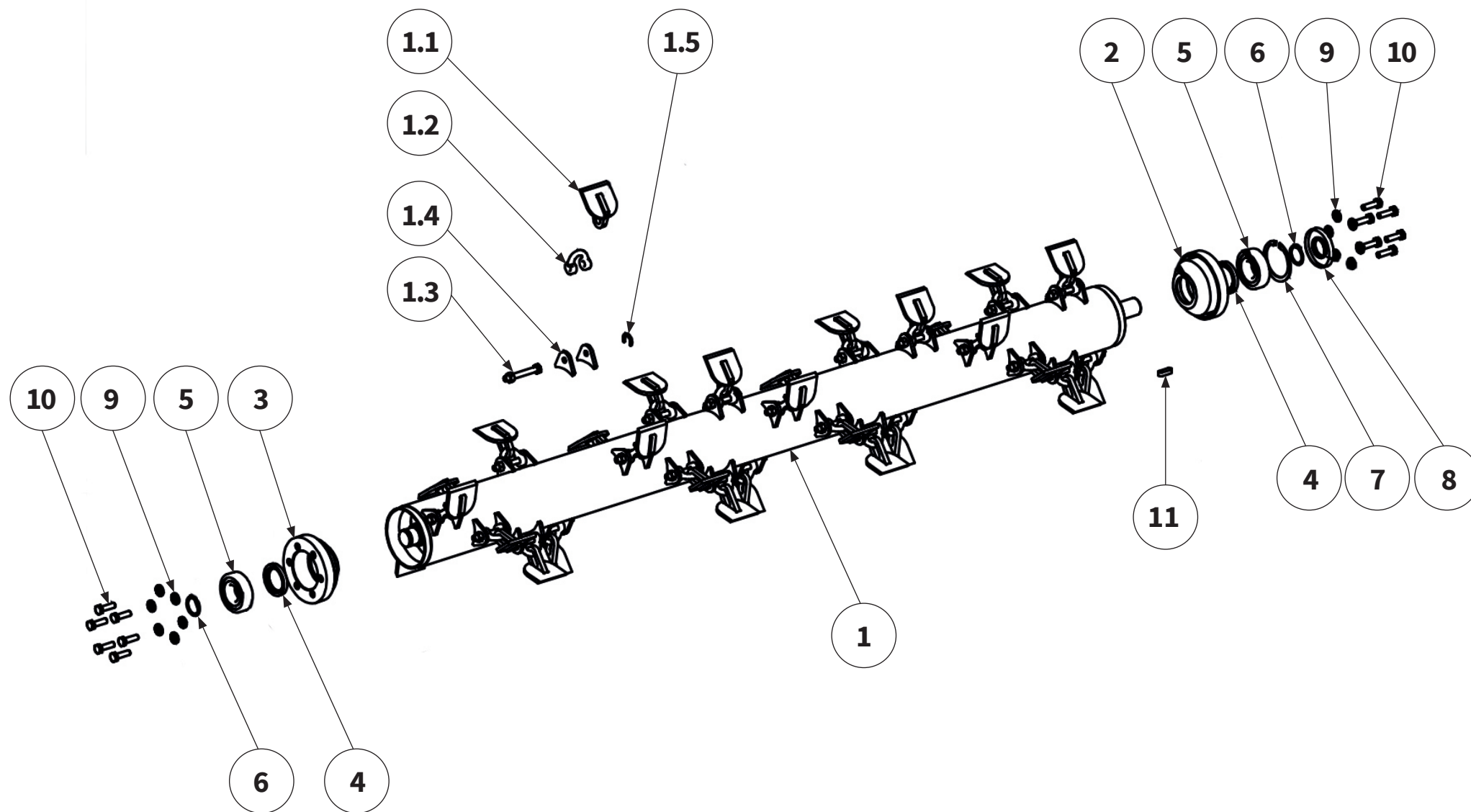

Pos.-Nr. No. Número	Ersatzteilnummer Manufacturer part number Numéro d'article du fabricant Número de pieza del fabricante					DE Bezeichnung	EN Designation	FR Désignation	ES Designación
	Anzahl quantity quantité número								
	MU-E 120	MU-E 140	MU-E 160	MU-E 180	MU-E 200				
1	00017419 1	00017384 1	00017078 1	00017236 1	00015218 1	Rotor inkl. Werkzeug	rotor with tools	Rotor avec outils	Rotor con herram
1.1	MU 4 20 24 28 32 36					Schäkelmesser	shackle flail	Lame de manille	Chuchilla del grillete
1.2	MU0801031 20 24 28 32 36					Schäkel	shackle	Manille	Grillete
1.3	MU0801041 20 24 28 32 36					Schraube mit Mutter	bolt with nut	Vis avec Écrou	Tornillo con Tuerca
1.4	00015026 40 48 56 64 72					Werkzeughalter	tool holders	Porte-outils	Porta herramientas
1.5	MU0702051 20 24 28 32 36					Verdrehsicherung	anti-twist protection	Sécurité anti-torsion	Seguro contra giro
2	00015217 1 1 1 1 1					Rotorlager- halterung	rotor holder	Support de Rotor	Soporte del Rotor
3	00015216 1 1 1 1 1					Rotorlager- halterung	rotor holder	Support de Rotor	Soporte del Rotor
4	MU981101 2 2 2 2 2					Wellendichtring	shaft seal	Baque à lèvres	Retén de eje
5	MU981102 2 2 2 2 2					Lager	bearing	Palier	Cojinete
6	MU490009 2 2 2 2 2					Sicherungsring	circlip	Bague de sécurité	Anillo de seguridad



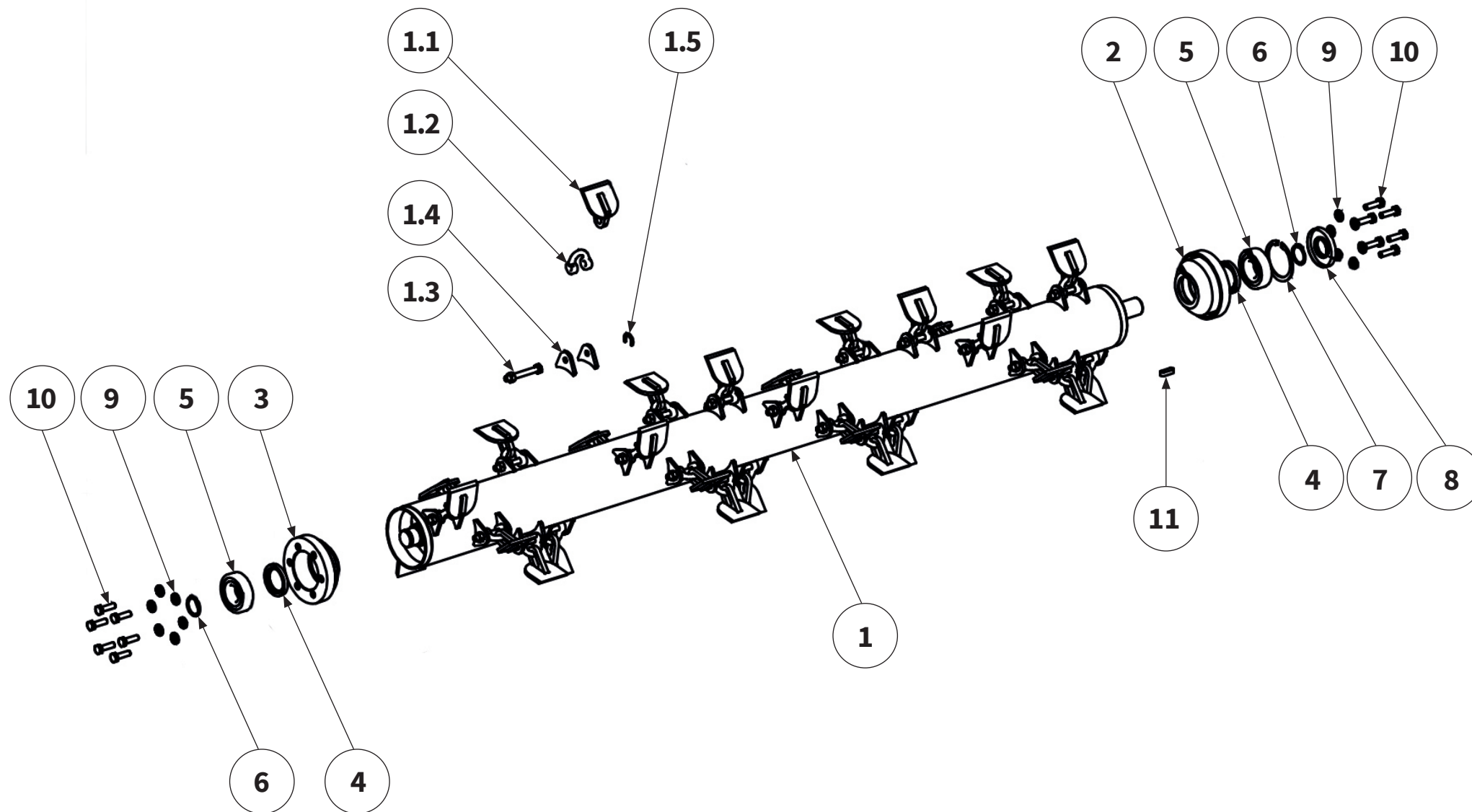

Pos.-Nr. No. Numéro Número	Ersatzteilnummer Manufacturer part number Numéro d'article du fabricant Número de pieza del fabricante					DE Bezeichnung	EN Designation	FR Désignation	ES Designación
	Anzahl quantity quantité número								
	MU-E 120	MU-E 140	MU-E 160	MU-E 180	MU-E 200				
7	MU981896					Sicherungsring	circlip	Bague de sécurité	Anillo de seguridad
	1	1	1	1	1				
8	MU623007					Wellendichtring	shaft seal	Baquet à lèvres	Retén de eje
	1	1	1	1	1				
9	MUNSKL10					Scheibe	washer	Disque	Arandela
	12	12	12	12	12				
10	MU980222					Schraube	bolt	Vis	Tornillo
	12	12	12	12	12				
11	MU0510092					Passfeder	parallel key	Clavette	Chaveta de ajuste
	1	1	1	1	1				



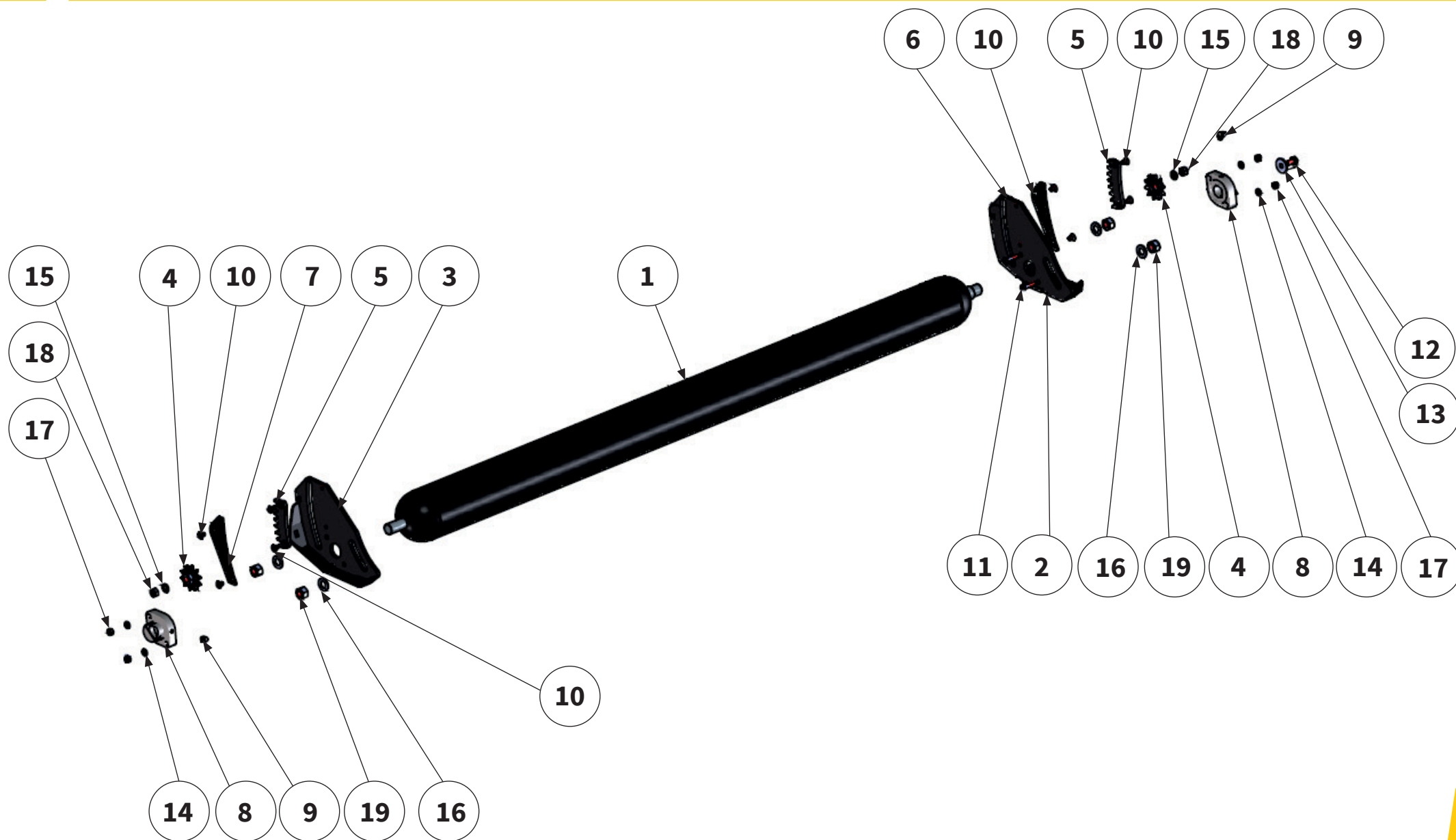

Pos.-Nr. No. Número	Ersatzteilnummer Manufacturer part number Numéro d'article du fabricant Número de pieza del fabricante					DE Bezeichnung	EN Designation	FR Désignation	ES Designación
	Anzahl quantity quantité número								
	MU-E 120	MU-E 140	MU-E 160	MU-E 180	MU-E 200				
1	MU0110792 1	MU0110793 1	MU0110794 1	MU0110795 1	MU0110796 1	Stützwalze	support roller	Rouleau d'appui	Cilindro de apoyo
2	00015272 1 1 1 1 1					Halteplatte	retainer plate	Plaque de support	Placa de retención
3	00015275 1 1 1 1 1					Halteplatte	retainer plate	Plaque de support	Placa de retención
4	00015277 2 2 2 2 2					Zahnrad	gearwheel	Roue dentée	Rueda dentada
5	00015278 2 2 2 2 2					Zahnstange	gear rack	Crémaillère	Cremallera
6	00015261 1 1 1 1 1					Nonius	nonius	Vernier	Nonio
7	00015262 1 1 1 1 1					Nonius	nonius	Vernier	Nonio
8	00001673 2 2 2 2 2					Flanschlager mit Kappe	flange with cap	Plaque de capuchon	Chapa de cubierta
8a	KAPPE 2 2 2 2 2					Abdeckkappe	protective cap	Capuchon de protection	Cubierta protection
9	H3 M08x1 2 2 2 2 2					Schmiernippel	lubricating nipple	Nipple de graissage	Engrasador
10	MU981902 8 8 8 8 8					Schraube	bolt	Vis	Tornillo

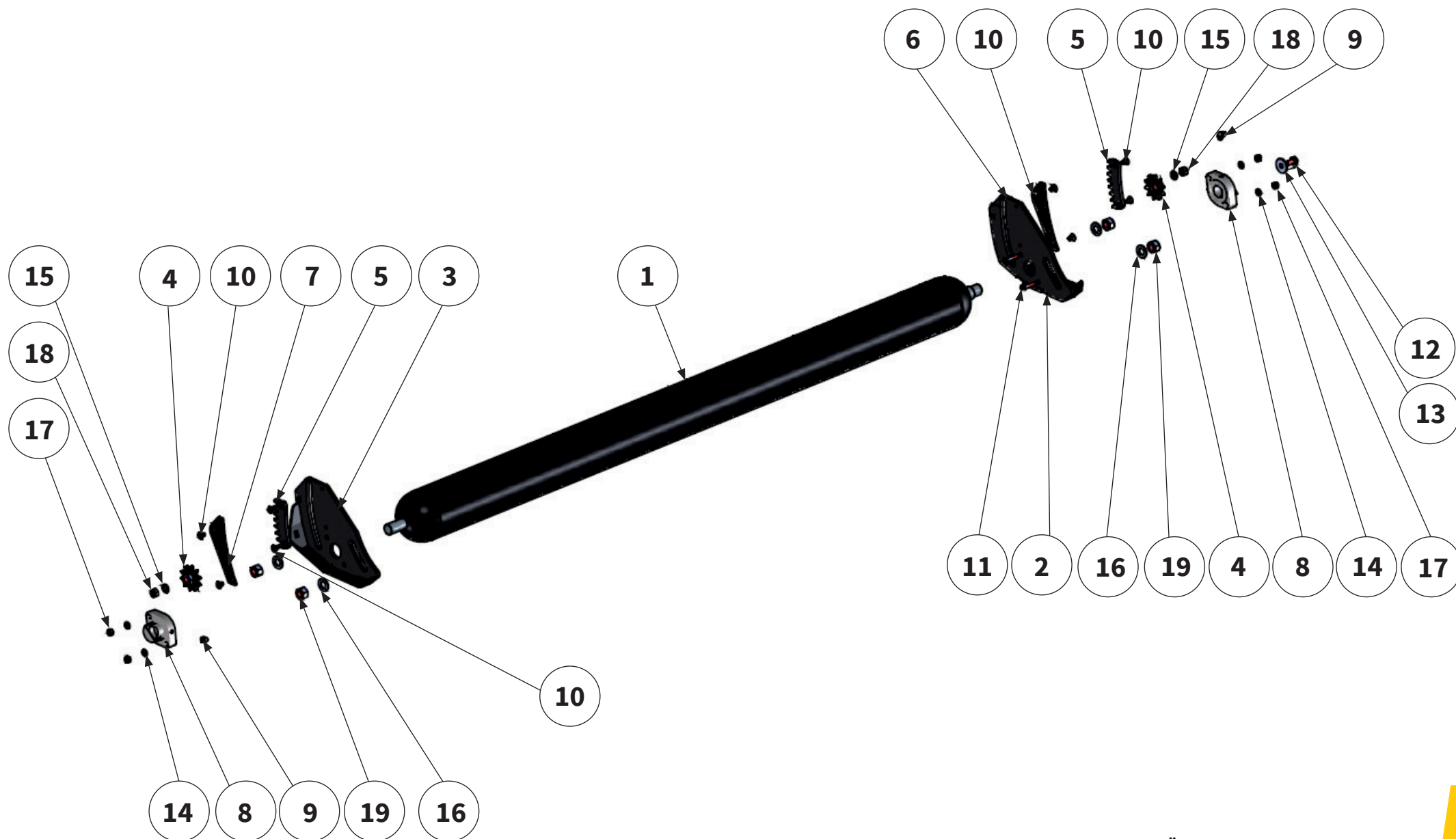

Pos.-Nr. No. Número	Ersatzteilnummer Manufacturer part number Numéro d'article du fabricant Número de pieza del fabricante					DE Bezeichnung	EN Designation	FR Désignation	ES Designación
	Anzahl quantity quantité número								
	MU-E 120	MU-E 140	MU-E 160	MU-E 180	MU-E 200				
11	MU981903					Schraube	bolt	Vis	Tornillo
	4	4	4	4	4				
12	MU0099970					Schraube	bolt	Vis	Tornillo
	1	1	1	1	1				
13	MU981904					Scheibe	washer	Disque	Arandela
	1	1	1	1	1				
14	MU980102					Scheibe	washer	Disque	Arandela
	4	4	4	4	4				
15	MU980202					Scheibe	washer	Disque	Arandela
	2	2	2	2	2				
16	MU980402					Scheibe	washer	Disque	Arandela
	4	4	4	4	4				
17	MU0099961					Mutter	nut	Écrou	Tuerca
	4	4	4	4	4				
18	MU980201					Mutter	nut	Écrou	Tuerca
	2	2	2	2	2				
19	MU980401					Mutter	nut	Écrou	Tuerca
	4	4	4	4	4				

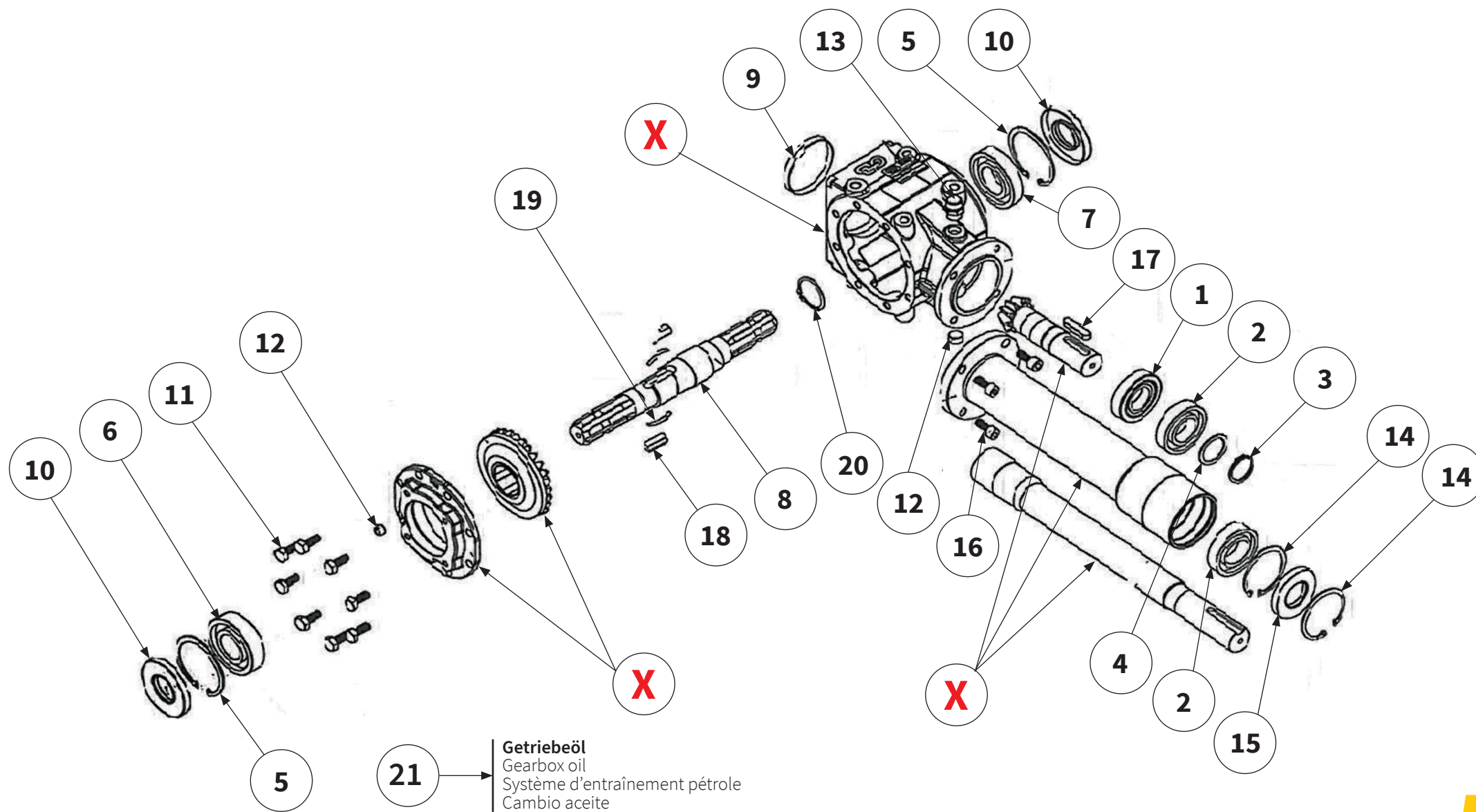

Pos.-Nr. No. Número	Ersatzteilnummer Manufacturer part number Numéro d'article du fabricant Número de pieza del fabricante					DE Bezeichnung	EN Designation	FR Désignation	ES Designación
	Anzahl quantity quantité número								
	MU-E 120	MU-E 140	MU-E 160	MU-E 180	MU-E 200				
1	MU310005					Lager	bearing	Palier	Cojinete
	1	1	1	1	1				
2	MU490029					Lager	bearing	Palier	Cojinete
	2	2	2	2	2				
3	MU490009					Sicherungsring	circlip	Bague de sécurité	Anillo de seguridad
	1	1	1	1	1				
4	MU7T1015					Distanzscheibe	spacer	Disque d'écartement	Arandela distanciadora
	1	1	1	1	1				
5	MU623014					Sicherungsring	circlip	Bague de sécurité	Anillo de seguridad
	2	2	2	2	2				
6	MU490023					Lager	bearing	Palier	Cojinete
	1	1	1	1	1				
7	MU623010					Lager	bearing	Palier	Cojinete
	1	1	1	1	1				
8	MU310012					Welle	drive shaft	Arbre de transmission	Eje de accionamiento
	1	1	1	1	1				
9	MU623004					Verschlussdeckel	cap	Couvercie de fermeture	Tapa de cierre
	1	1	1	1	1				
10	MU623007					Wellendichtring	shaft seal	Baque d'levre	Retén de eye
	2	2	2	2	2				
11	MU980208					Schraube	bolt	Vis	Tornillo
	8	8	8	8	8				
X	Teile einzeln vom Hersteller nicht lieferbar Parts from the manufacturer cannot be supplied individually Pièces non livrables séparément par le fabricant El fabricante no suministra piezas individuales								

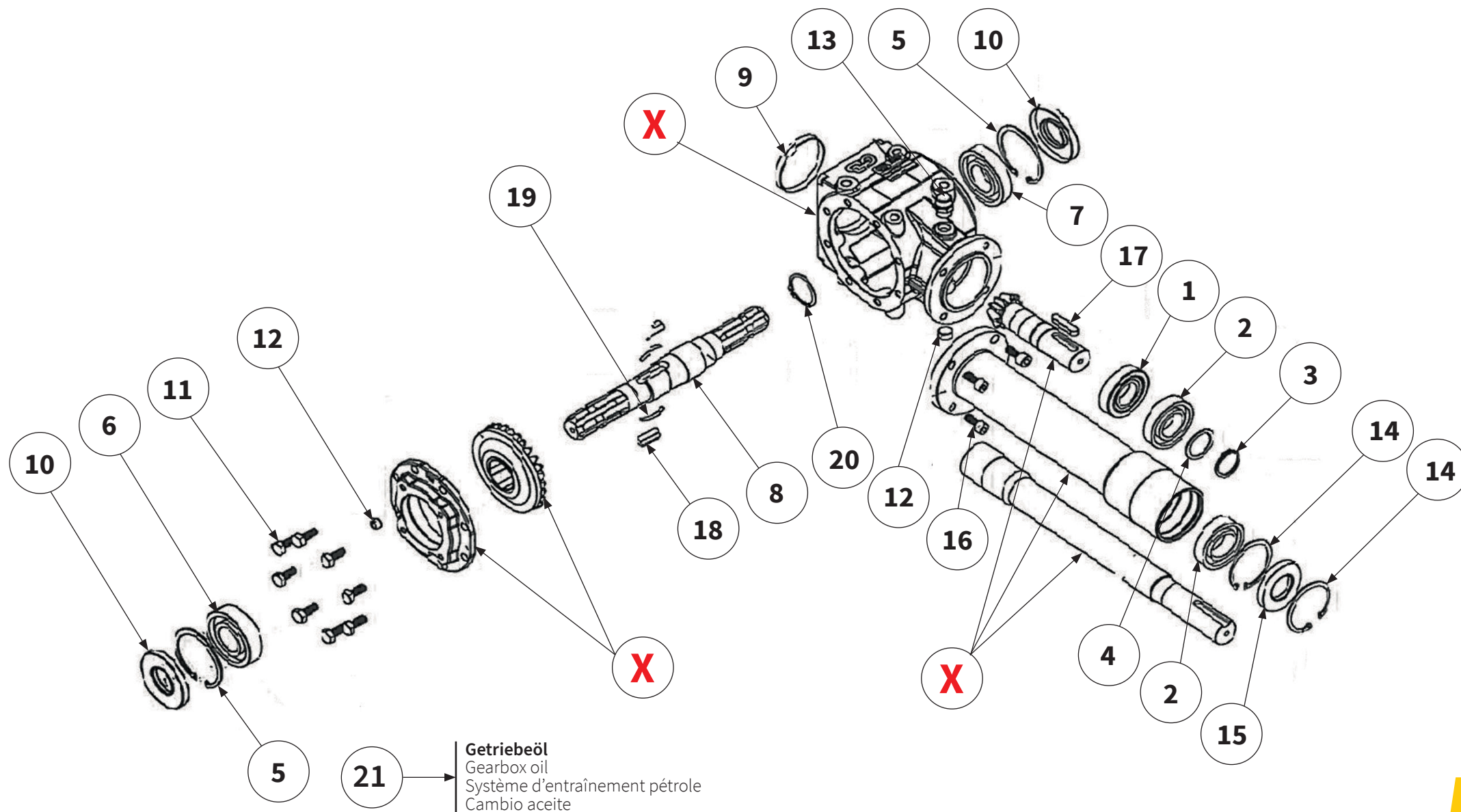

Pos.-Nr. No. Número	Ersatzteilnummer Manufacturer part number Numéro d'article du fabricant Número de pieza del fabricante					DE Bezeichnung	EN Designation	FR Désignation	ES Designación
	Anzahl quantity quantité número								
	MU-E 120	MU-E 140	MU-E 160	MU-E 180	MU-E 200				
12	MU623017					Ablasskontrollschraube	bolt	Vis	Tornillo
	2	2	2	2	2				
13	MU623018					Getriebeentlüftung	gearbox breather	boîte de vitesses reniflard	respiradero de la caja de cambios
	1	1	1	1	1				
14	MU310021					Sicherungsring	circlip	Bague de sécurité	Anillo de seguridad
	2	2	2	2	2				
15	MU310022					Wellendichtring	shaft seal	Baque d'levre	Retén de eye
	1	1	1	1	1				
16	MU310023					Schraube	bolt	Vis	Tornillo
	4	4	4	4	4				
17	MU310024					Passfeder	parallel key	Clavette	Chaveta de ajuste
	1	1	1	1	1				
18	MU623008					Sperrklinke	detent freewheel	cliquet d'arrêt roue libre	trinquete de bloqueo rueda libre
	2	2	2	2	2				
19	MU490025					Feder	spring	Ressort	Resorte
	2	2	2	2	2				
20	MU623013					Sicherungsring	circlip	Bague de sécurité	Anillo de seguridad
	1	1	1	1	1				
21	MUSAE70W90VS (1l)					Getriebeöl	gearbox oil	Système d'entraînement pétrole	Cambio aceite
	2	2	2	2	2				
21a	1,15 l	1,2 l	1,25 l	1,3 l	1,3 l	Füllmenge inkl. Verlängerungswelle	Oil fill quantity included extension shaft	Quantité d'huile incluse Arbre de rallonge	Cantidad de llenado de aceite inclusive Eje de prolongación
X	Teile einzeln vom Hersteller nicht lieferbar Parts from the manufacturer cannot be supplied individually Pièces non livrables séparément par le fabricant El fabricante no suministra piezas individuales								

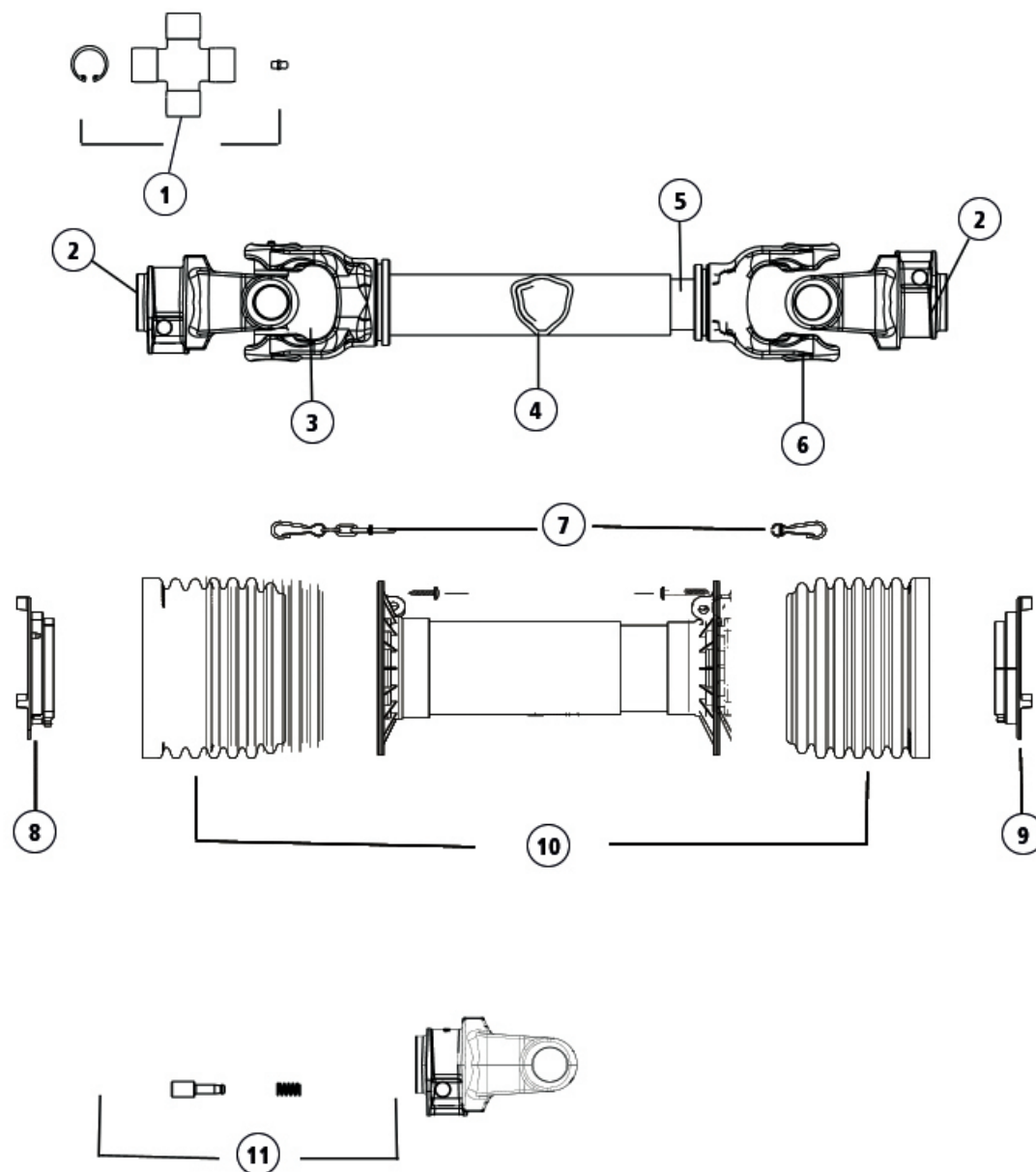

Pos.-Nr. No. Número	Ersatzteilnummer Manufacturer part number Numéro d'article du fabricant Número de pieza del fabricante					DE Bezeichnung	EN Designation	FR Désignation	ES Designación
	Anzahl quantity quantité número								
	MU-E 120	MU-E 140	MU-E 160	MU-E 180	MU-E 200				
1	4120E0012R25					Kreuzgarnitur	Cross Kit	Croisillon	Crucetas
	2	2	2	2	2				
2	5070E0355					Außengabel	Outer Yoke	Mâchoires	Horquillas
	2	2	2	2	2				
3	204046851					Innengabel für Außenrohr	Outer Yoke Teleskop-Tube	Mâchoires pour tube extérieur	Horquillas para tubo exterior
	1	1	1	1	1				
4	125081000R06					Profil-Außenrohr	Outer Telescope Tube	Tube externe	Tubo exterior
	1	1	1	1	1				
5	125071000R06					Profil-Innenrohr	Inner Telescope Tube	Tube interne	Tubo interior
	1	1	1	1	1				
6	204046852					Innengabel für Innenrohr	Inner Yoke Telescope Tube	Mâchoires pour tube intérieur	Horquillas para tubo interior
	1	1	1	1	1				
7	252000050R02					Haltekette	chain	Chaînes de retenue	Cadenas de seguridad
	2	2	2	2	2				
8	255041002R02					Lauftring	Raceway	Paliers de glissement	Anillo soporte
	1	1	1	1	1				
9	255041001R02					Lauftring	Raceway	Paliers de glissement	Anillo soporte
	1	1	1	1	1				
10	5CG4086FXSS					Gelenkwellen- schutz	Safety Shield complete	Protection contre les accidents	Protecciones de seguridad
	1	1	1	1	1				
11	403000001					Schiebestift	Push Pin Kit	Veru rapide	Pulsador
	2	2	2	2	2				

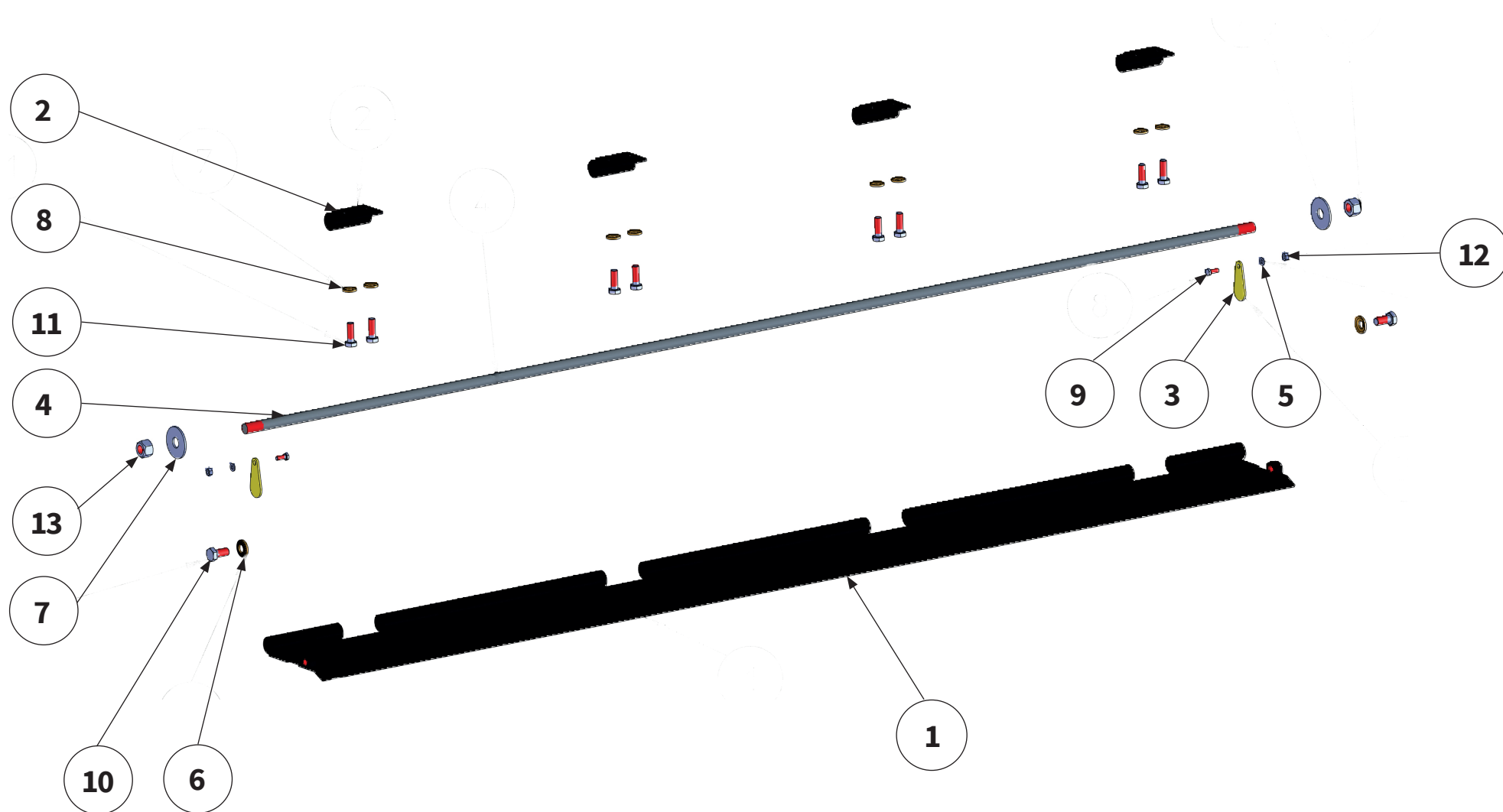

Pos.-Nr. No. Numéro Número	Ersatzteilnummer Manufacturer part number Numéro d' article du fabricant Número de pieza del fabricante					DE Bezeichnung	EN Designation	FR Désignation	ES Designación
	Anzahl quantity quantité número								
	MU-E 120	MU-E 140	MU-E 160	MU-E 180	MU-E 200				
1	00017423 1	00017387 1	00017179 1	00017352 1	00015298 1	Kurzschnittklappe	short-cut flap	Clapet de coupe courte	Tapa de corte corto
2	2	2	00015304 4	4	4	Kurzschnitt- klappenhalter	holder	Support	Soporte
3	2	2	00017538 2	2	2	Sicherheits- abdeckung	cover	Recouvrement	Cubierta
4	00017544 1	00017543 1	00017542 1	00017540 1	00017539 1	Welle	shaft	Arbre	Eje
5	2	2	MU980011 2	2	2	Scheibe	washer	Disque	Arandela
6	2	2	MUNSKL12 2	2	2	Scheibe	washer	Disque	Arandela
7	2	2	MU980403 2	2	2	Scheibe	washer	Disque	Arandela
8	4	4	MUNSKL10 8	8	8	Scheibe	washer	Disque	Arandela
9	2	2	MU980004 2	2	2	Schraube	bolt	Vis	Tornillo
10	2	2	MU980341 2	2	2	Schraube	bolt	Vis	Tornillo
11	4	4	MU980205 8	8	8	Schraube	bolt	Vis	Tornillo
12	2	2	MU980010 2	2	2	Mutter	nut	Écrou	Tuerca
13	2	2	MU980401 2	2	2	Mutter	nut	Écrou	Tuerca



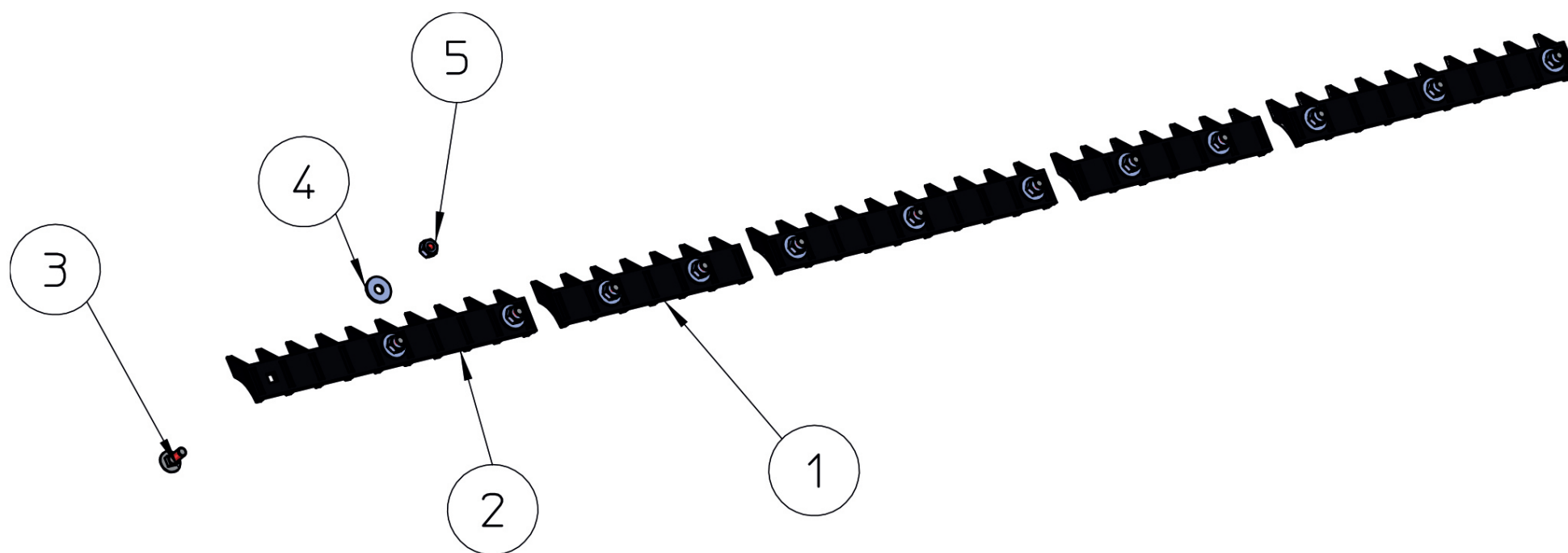

Pos.-Nr. No. Numéro Número	Ersatzteilnummer Manufacturer part number Numéro d' article du fabricant Número de pieza del fabricante					DE Bezeichnung	EN Designation	FR Désignation	ES Designación
	Anzahl quantity quantité número								
	MU-E 120	MU-E 140	MU-E 160	MU-E 180	MU-E 200				
1	-	2	00005516 -	2	-	Gegenschneide 300	short-chopping bar	Lame hache-paille courte	Listón de corte de paja corto
2	3	2	00005518 4	3	5	Gegenschneide 400	short-chopping bar	Lame hache-paille courte	Listón de corte de paja corto
3	9	10	00000904 12	13	15	Schraube	bolt	Vis	Tornillo
4	9	10	MU0099950 12	13	15	Scheibe	washer	Disque	Arandela
5	9	10	MU0099960 12	13	15	Mutter	nut	Écrou	Tuerca



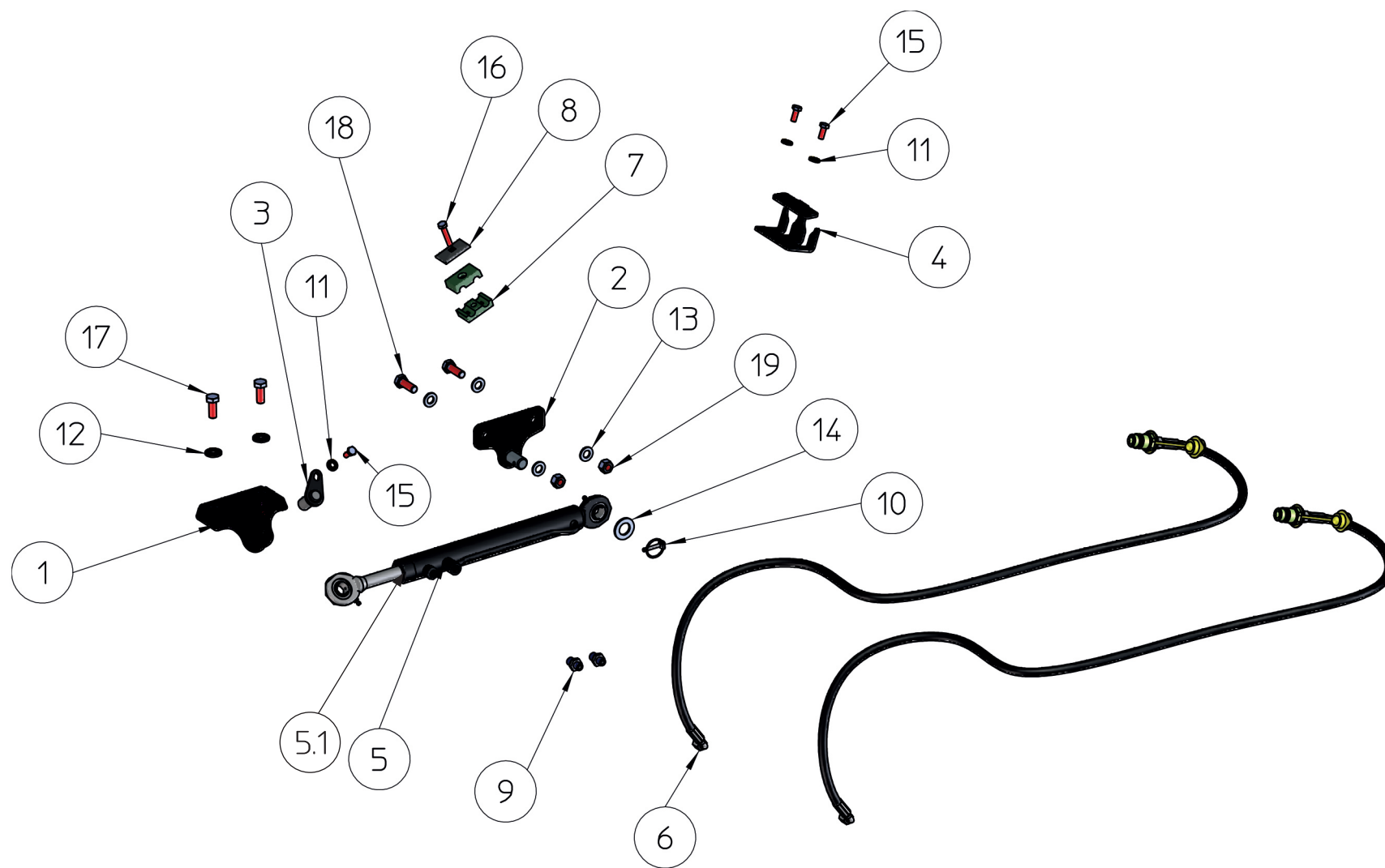

Pos.-Nr. No. Numéro Número	Ersatzteilnummer Manufacturer part number Numéro d'article du fabricant Número de pieza del fabricante					DE Bezeichnung	EN Designation	FR Désignation	ES Designación
	Anzahl quantity quantité número								
	MU-E 120	MU-E 140	MU-E 160	MU-E 180	MU-E 200				
1	-	1	1	1	-	Zylinderhalter	cylinder bracket	Porte-cylindre	Portacilindro
2	-	1	1	1	-	Zylinderhalter	cylinder bracket	Porte-cylindre	Portacilindro
3	-	1	1	1	-	Lasche	pin	Axe	Perno
4	-	1	1	1	-	Hydraulikhalter	holder	Support	Soporte
5	-	1	1	1	-	Hydraulikzylinder	hydraulic cylinder	Vérin hydraulique	Cilindro hidráulico
5.1	-	1	1	1	-	Dichtsatz	packet seal	Kit d'étanchéité	Juego de estanqueización
6	-	2	2	2	-	Hydraulikschlauch	hydraulic hose	Tuyau hydraulique	Tubo flexible hidráulico
7	-	1	1	1	-	Schellenkörper	clamp body	Corps de collier	Cuerpo de la abrazadera
8	-	1	1	1	-	Deckplatte	cover plate	Plaque de recouvrement	Placa de revestimiento
9	-	2	2	2	-	Verschraubung	Screwed connection	Raccord à vis	Atornillamiento
10	-	1	1	1	-	Klappsplint	lynch pin	Esse d'essieu	Pasador abatible
11	-	3	3	3	-	Scheibe	washer	Disque	Arandela



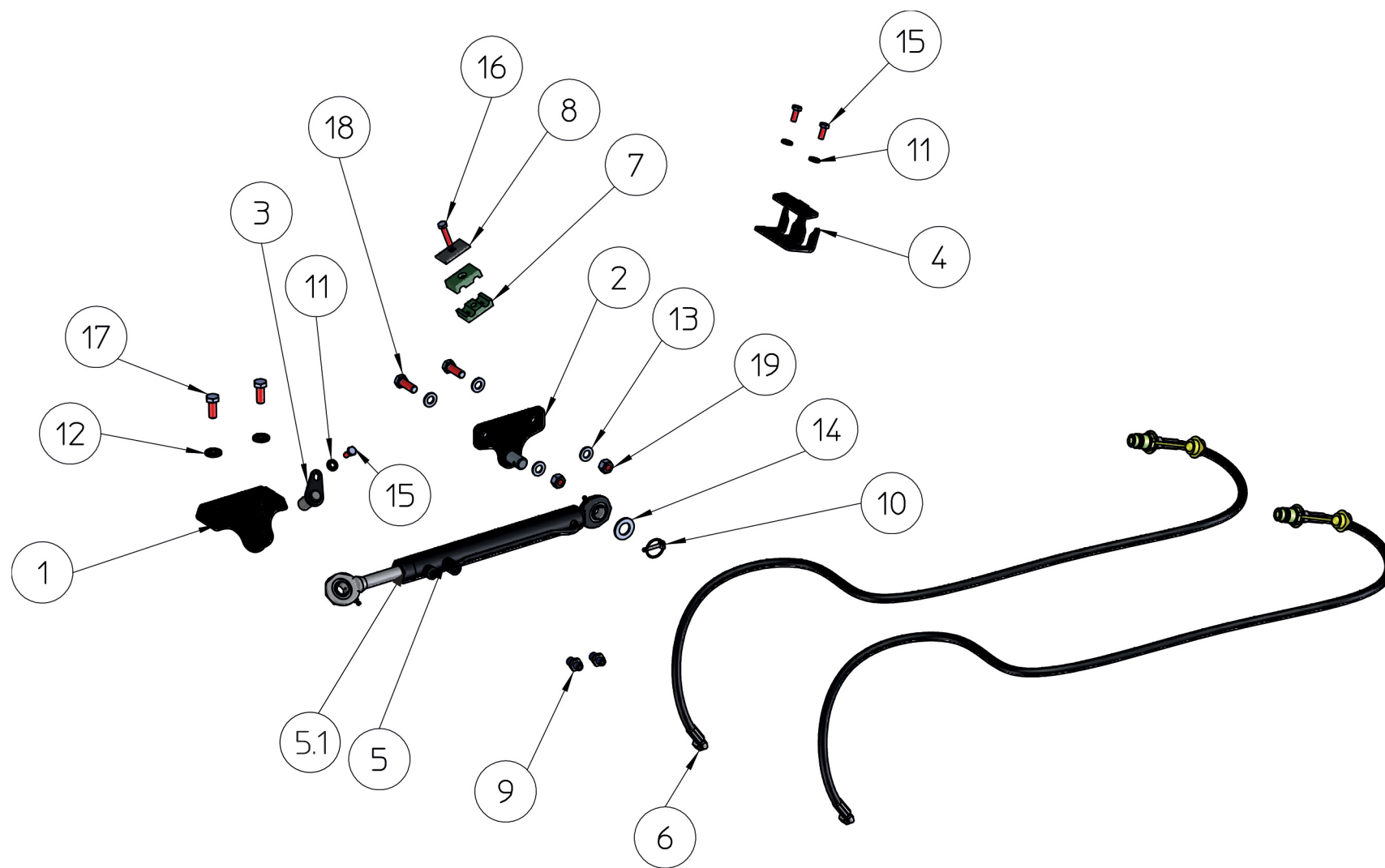

Pos.-Nr. No. Número	Ersatzteilnummer Manufacturer part number Numéro d' article du fabricant Número de pieza del fabricante					DE Bezeichnung	EN Designation	FR Désignation	ES Designación
	Anzahl quantity quantité número								
	MU-E 120	MU-E 140	MU-E 160	MU-E 180	MU-E 200				
12	-	4	4	4	-	Scheibe	washer	Disque	Arandela
13	-	4	4	4	-	Scheibe	washer	Disque	Arandela
14	-	1	1	1	-	Scheibe	washer	Disque	Arandela
15	-	3	3	3	-	Schraube	bolt	Vis	Tornillo
16	-	1	1	1	-	Schraube	bolt	Vis	Tornillo
17	-	2	2	2	-	Schraube	bolt	Vis	Tornillo
18	-	2	2	2	-	Schraube	bolt	Vis	Tornillo
19	-	2	2	2	-	Mutter	nut	Écrou	Tuerca



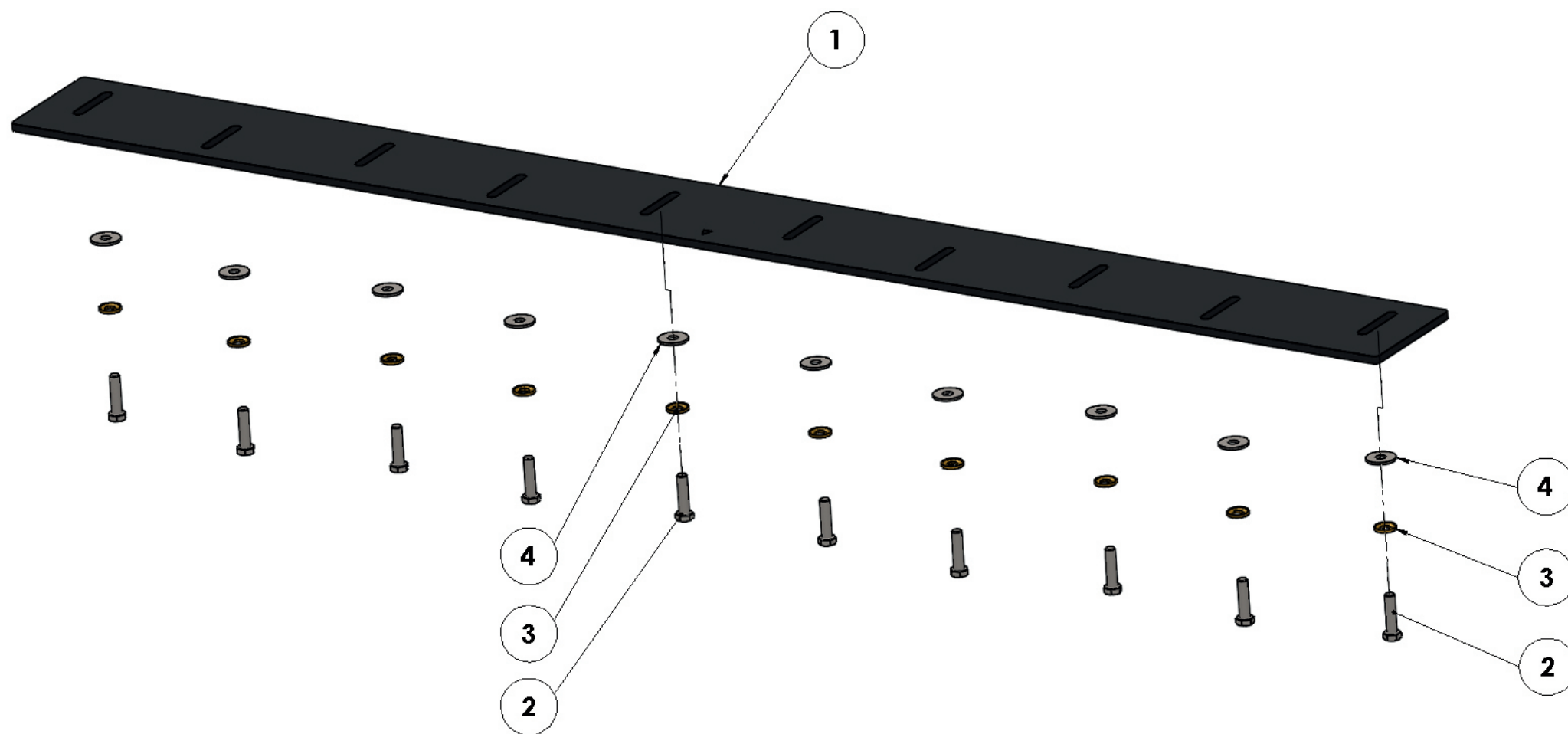

Pos.-Nr. No. Numéro Número	Ersatzteilnummer Manufacturer part number Numéro d' article du fabricant Número de pieza del fabricante					DE Bezeichnung	EN Designation	FR Désignation	ES Designación
	Anzahl quantity quantité número								
	MU-E 120	MU-E 140	MU-E 160	MU-E 180	MU-E 200				
1	00017425 1	00017389 1	00017364 1	00017356 1	00017325 1	Schneidblech	cutting bar	Règle coupante	Carril de corte
2	MU980205 11 13 17 19 21					Schraube	bolt	Vis	Tornillo
3	MUNSKL10 11 13 17 19 21					Scheibe	washer	Disque	Arandela
4	MU0099950 11 13 17 19 21					Scheibe	washer	Disque	Arandela



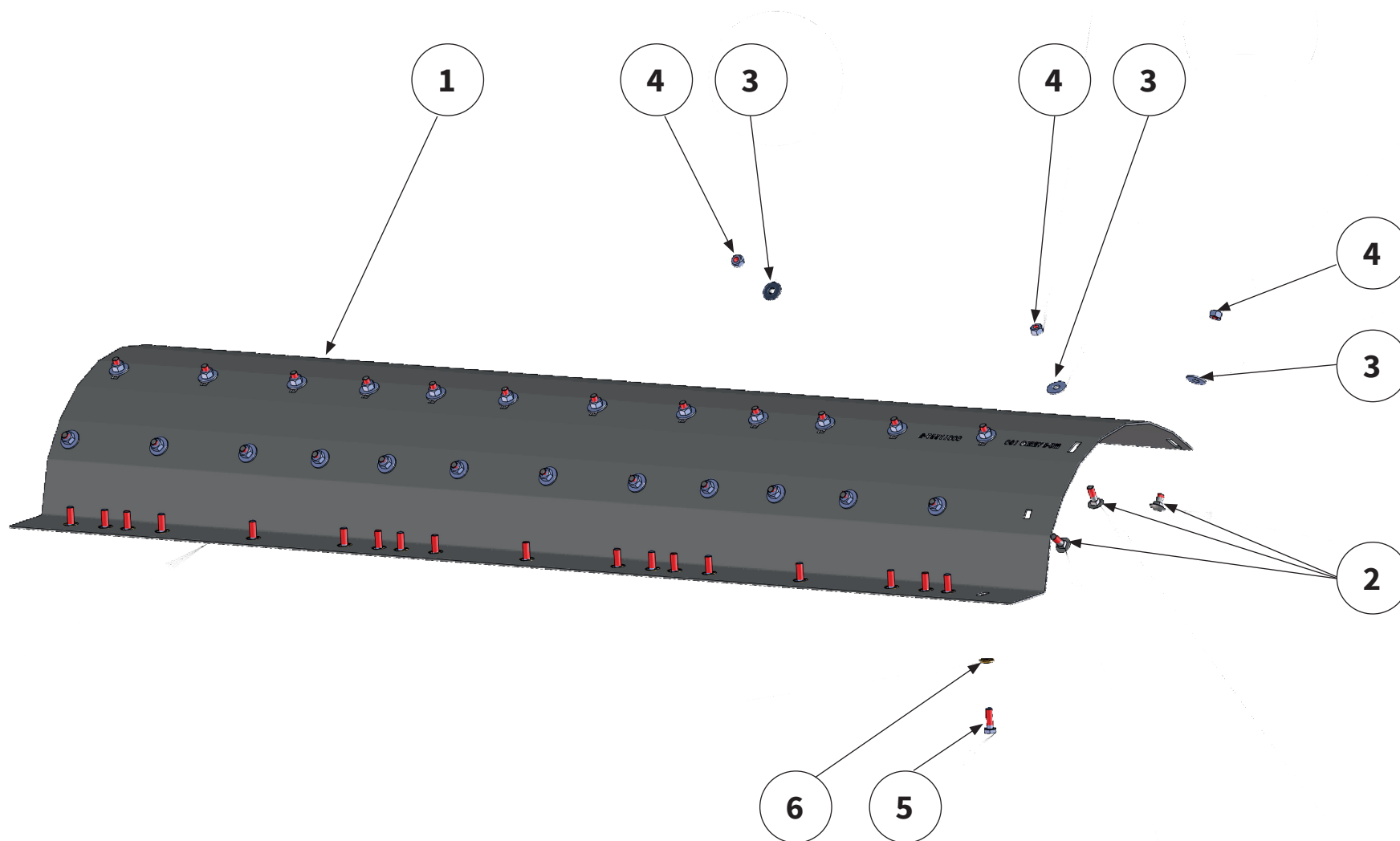

Pos.-Nr. No. Numéro Número	Ersatzteilnummer Manufacturer part number Numéro d' article du fabricant Número de pieza del fabricante					DE Bezeichnung	EN Designation	FR Désignation	ES Designación
	Anzahl quantity quantité número								
	MU-E 120	MU-E 140	MU-E 160	MU-E 180	MU-E 200				
1	00017426 1	00017391 1	00017181 1	00017357 1	00017312 1	Verschleißeinlage	wear insert	Blindage	Junta de desgaste
2	MU980206 18 18 18 24 24					Schraube	bolt	Vis	Tornillo
3	MU0099950 18 18 18 24 24					Scheibe	washer	Disque	Arandela
4	MU0099960 18 18 18 24 24					Mutter	nut	Écrou	Tuerca
5	MU980205 11 13 17 19 21					Schraube	bolt	Vis	Tornillo
6	MUNSKL10 11 13 17 19 21					Scheibe	washer	Disque	Arandela



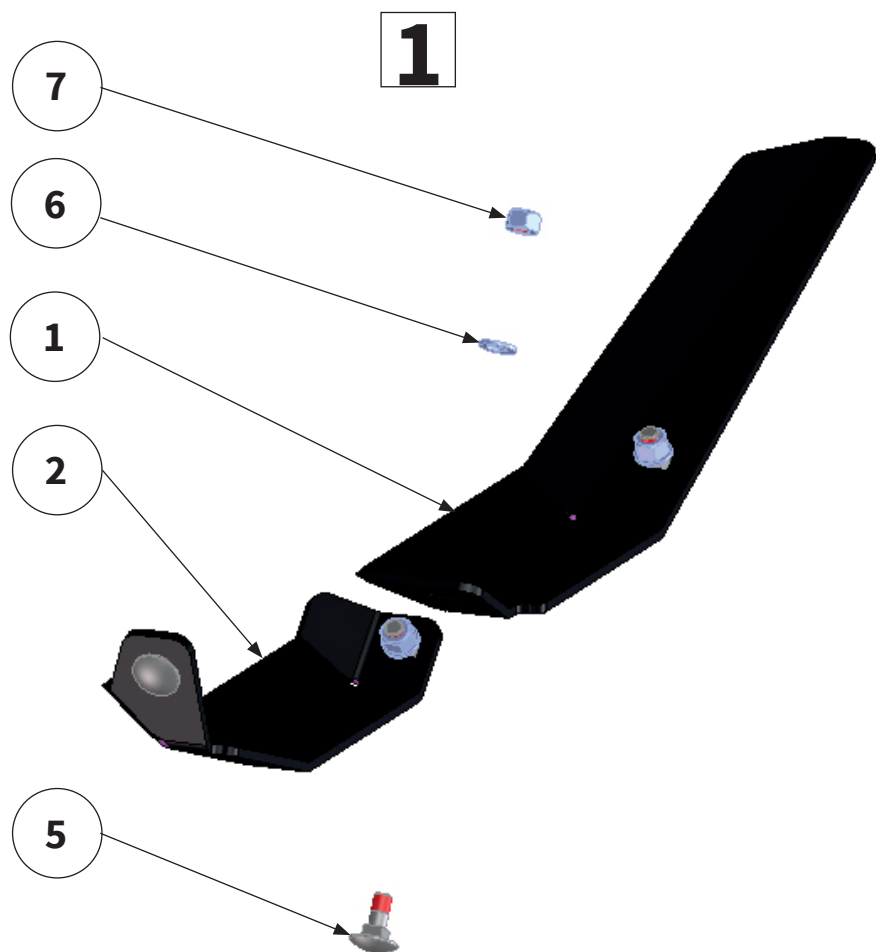

Fahrtrichtung links
 direction of travel left
 dans le sens de la marche á gauche
 en sentido de marcha a la izquierda

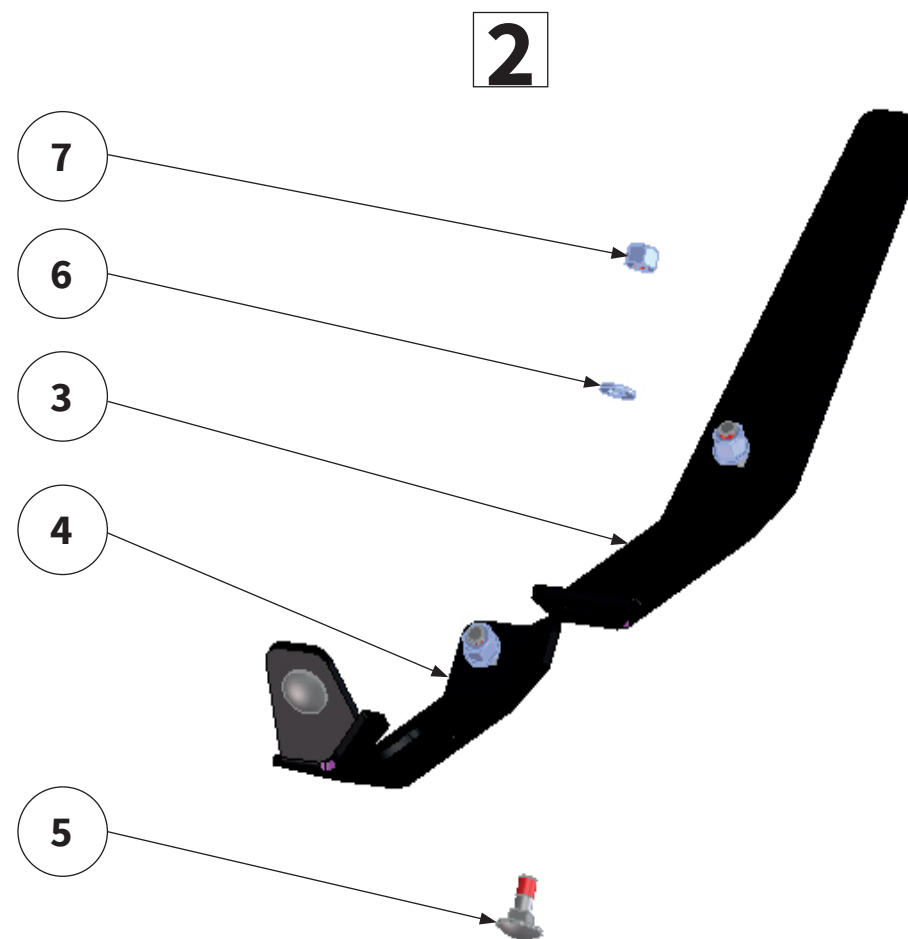

Fahrtrichtung rechts
 direction of travel right
 dans le sens de la marche á droite
 en sentido de la marcha a la derecha

1

Pos.-Nr. No. Número Número	Ersatzteilnummer Manufacturer part number Numéro d'article du fabricant Número de pieza del fabricante					DE Bezeichnung	EN Designation	FR Désignation	ES Designación
	Anzahl quantity quantité número								
	MU-E 120	MU-E 140	MU-E 160	MU-E 180	MU-E 200				
1	00015313					Verschleißkufe	wear runner	Patin d'usure	Cuchilla de desgaste
	1	1	1	1	1				
2	00015315					Verschleißkufe	wear runner	Patin d'usure	Cuchilla de desgaste
	1	1	1	1	1				
5	MU980107					Schraube	bolt	Vis	Tornillo
	4	4	4	4	4				
6	MU980102					Scheibe	washer	Disque	Arandela
	4	4	4	4	4				
7	MU0099961					Mutter	nut	Écrou	Tuerca
	4	4	4	4	4				

2

Pos.-Nr. No. Número Número	Ersatzteilnummer Manufacturer part number Numéro d'article du fabricant Número de pieza del fabricante					DE Bezeichnung	EN Designation	FR Désignation	ES Designación
	Anzahl quantity quantité número								
	MU-E 120	MU-E 140	MU-E 160	MU-E 180	MU-E 200				
3	00015314					Verschleißkufe	wear runner	Patin d'usure	Cuchilla de desgaste
	1	1	1	1	1				
4	00015316					Verschleißkufe	wear runner	Patin d'usure	Cuchilla de desgaste
	1	1	1	1	1				
5	MU980107					Schraube	bolt	Vis	Tornillo
	4	4	4	4	4				
6	MU980102					Scheibe	washer	Disque	Arandela
	4	4	4	4	4				
7	MU0099961					Mutter	nut	Écrou	Tuerca
	4	4	4	4	4				

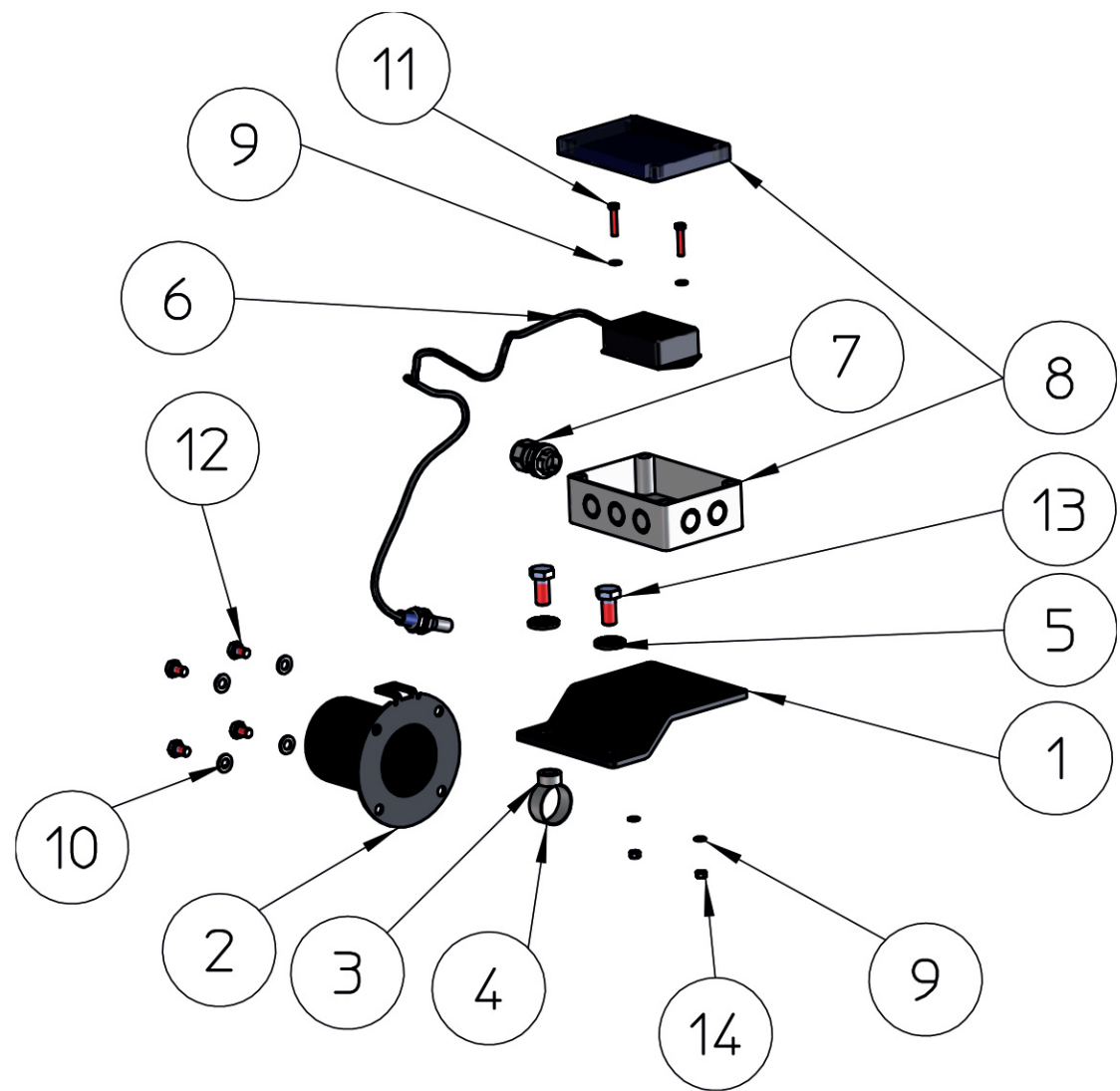

Pos.-Nr. No. Número Número	Ersatzteilnummer Manufacturer part number Numéro d' article du fabricant Número de pieza del fabricante					DE Bezeichnung	EN Designation	FR Désignation	ES Designación
	Anzahl quantity quantité número								
	MU-E 120	MU-E 140	MU-E 160	MU-E 180	MU-E 200				
1	1	1	00017546 1	1	1	Halter	holder	Support	Soporte
2	1	1	00017323 1	1	1	Sensorhalterung	holder	support	Soporte
3	1	1	00008229 1	1	1	Drehzahlgeber- magnet	engine speed sensor magnet	régulateur de vitesse Aimant	transmisor del número de revolu- ciones Imán
4	1	1	00017319 1	1	1	Drehzahlgeber- magnet mit Schelle	engine speed sensor magnet clamp body	régulateur de vitesse Aimant Cuerpo de la abrazadera	transmisor del número de revolu- ciones Imán Corps de collier
5	2	2	MUNSKL12 2	2	2	Scheibe	washer	Disque	Arandela
6	1	1	00015048 1	1	1	Betriebsstunden- zähler	operating hours counter	Compteur horaire	Contador de horas de servicio
7	1	1	00008094 1	1	1	Einrastver- schraubung	srew connection	connexion à vis	conexión por tornillo
8	1	1	00010187 1	1	1	Verteilerkasten	distribution box	boîte de distribution	caja de distribución
9	4	4	MU980006 4	4	4	Scheibe	washer	Disque	Arandela
10	4	4	MU980102 4	4	4	Scheibe	washer	Disque	Arandela
11	2	2	MU980008 2	2	2	Schraube	bolt	Vis	Tornillo
12	4	4	MU980159 4	4	4	Schraube	bolt	Vis	Tornillo
13	2	2	MU980341 2	2	2	Schraube	bolt	Vis	Tornillo
14	2	2	MU980009 2	2	2	Mutter	nut	Écrou	Tuerca

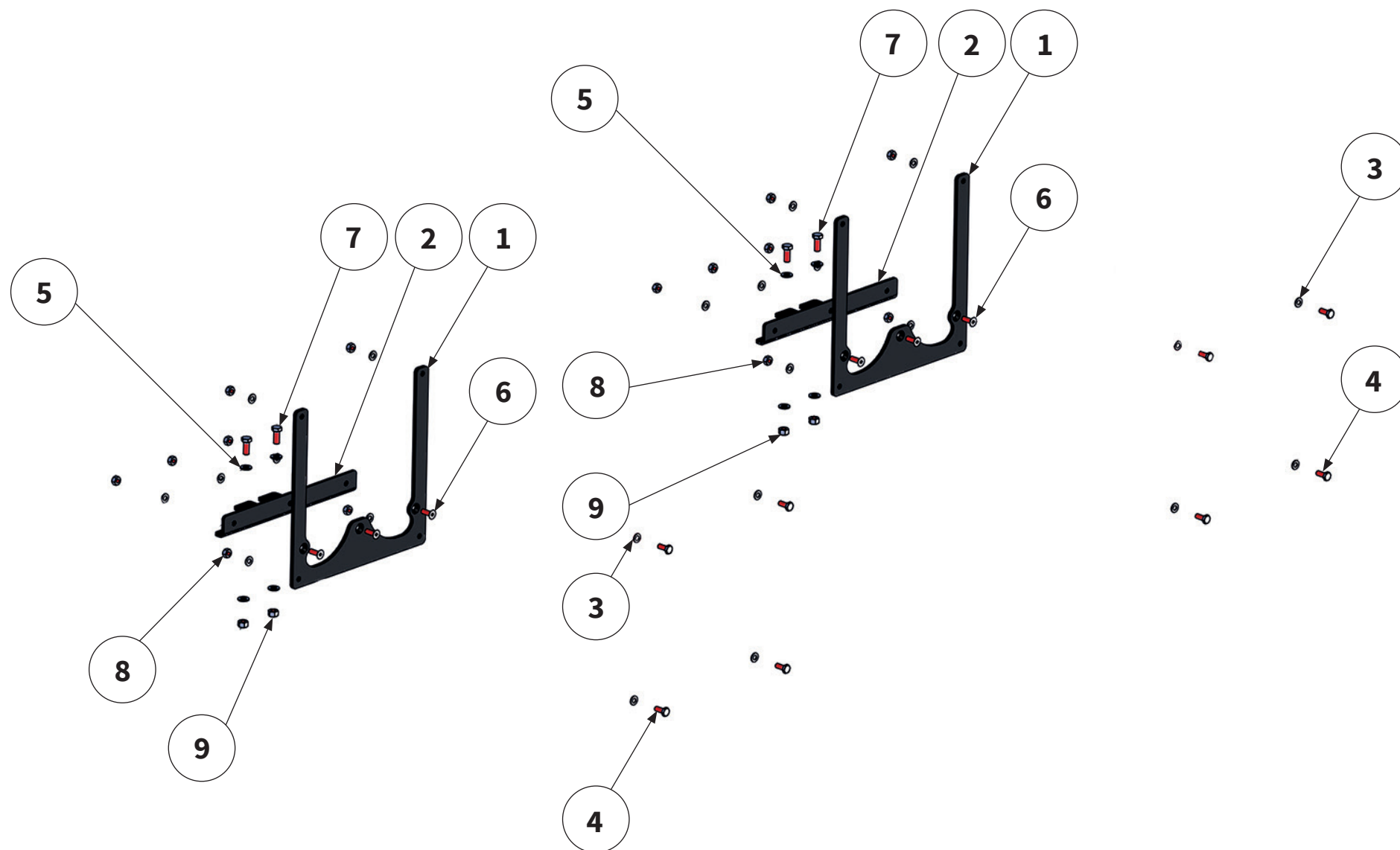

Pos.-Nr. No. Numéro Número	Ersatzteilnummer Manufacturer part number Numéro d'article du fabricant Número de pieza del fabricante					DE Bezeichnung	EN Designation	FR Désignation	ES Designación
	Anzahl quantity quantité número								
	MU-E 120	MU-E 140	MU-E 160	MU-E 180	MU-E 200				
1	00014968					Warntafelhalter	warning sign holder	Support de panneau de signalisation	Soporte del panel de aviso
	2	2	2	2	2				
2	00017317					Beleuchtungs- halter	holder	Support	Soporte
	2	2	2	2	2				
3	MU980202					Scheibe	washer	Disque	Arandela
	22	22	22	22	22				
4	MU980208					Schraube	bolt	Vis	Tornillo
	8	8	8	8	8				
5	MU980302					Scheibe	washer	Disque	Arandela
	8	8	8	8	8				
6	MU980252					Schraube	bolt	Vis	Tornillo
	6	6	6	6	6				
7	MU980307					Schraube	bolt	Vis	Tornillo
	4	4	4	4	4				
8	MU0099960					Mutter	nut	Écrou	Tuerca
	14	14	14	14	14				
9	MU980301					Mutter	nut	Écrou	Tuerca
	4	4	4	4	4				



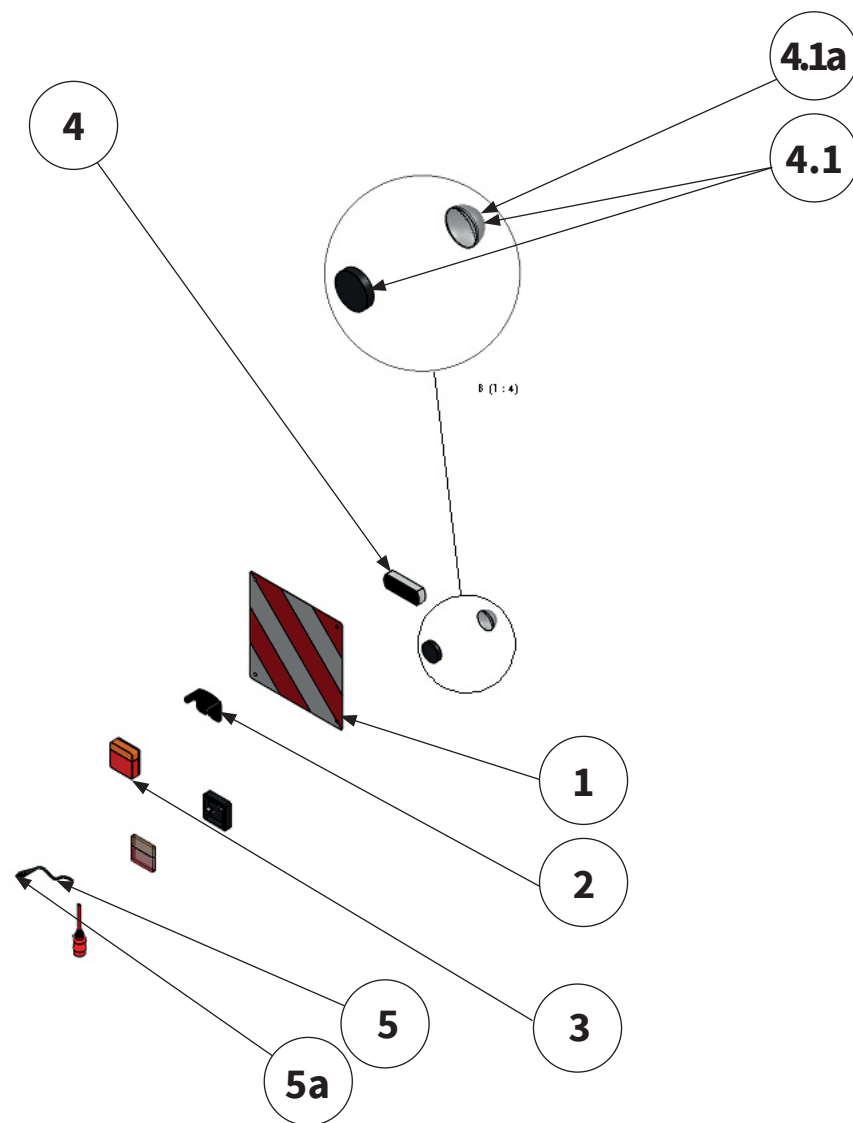
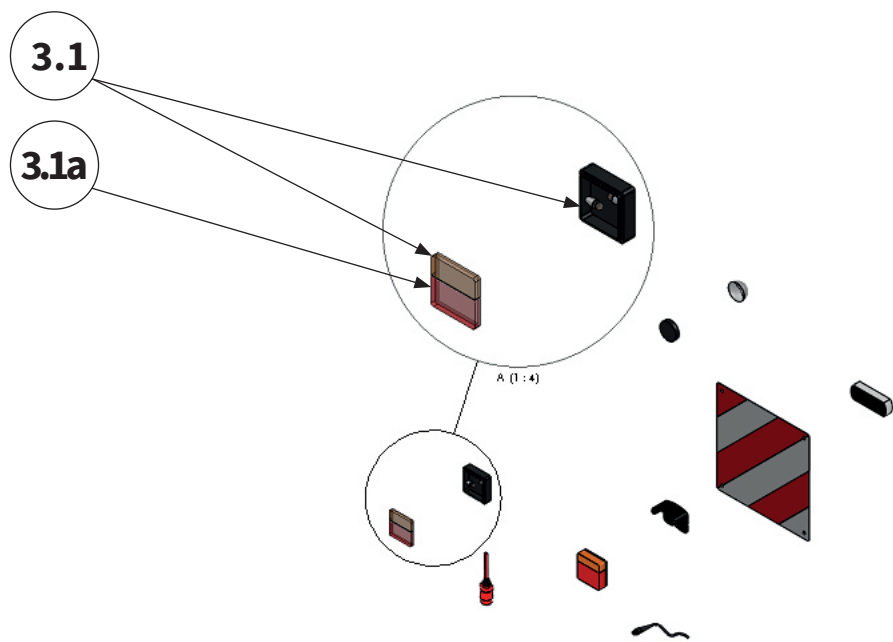

Pos.-Nr. No. Número	Ersatzteilnummer Manufacturer part number Numéro d'article du fabricant Número de pieza del fabricante					DE Bezeichnung	EN Designation	FR Désignation	ES Designación
	Anzahl quantity quantité número								
	MU-E 120	MU-E 140	MU-E 160	MU-E 180	MU-E 200				
1	R 1130/B					Warntafel	warning sign	Panneau de signalisation	Panel de aviso
	2	2	2	2	2				
2	308026-0230					Schutzabdeckung	protection cover	Recouvrement de protection	Cubierta protectora
	2	2	2	2	2				
3	3H3148-001					LED Blinkerleuchte	LED Direction indicator	LED luminaire fclignotant	LED lámpara intermitente
	2	2	2	2	2				
3a	319016-0020					Leuchte kpl.	light cpl.	Luminaire	Lámpara
	2	2	2	2	2				
3.1a	3L3348-002					Deckel	cap	Couvercle	Tapa
	2	2	2	2	2				
4	2P3158-011					LED Positionsleuchte	LED position light	LED position clignotant	LED Pilotos delanteros de posición
	2	2	2	2	2				
4a	319016-0021					Leuchte kpl.	light cpl.	Luminaire	Lámpara
	2	2	2	2	2				
4.1a	2L3348-001					Deckel	cap	Couvercle	Tapa
	2	2	2	2	2				
5	130400-016 (5m)					LED Verbindungskabel	LED connecting cable	LED câble de connexion	LED cable de conexión
	2	2	2	2	2				
5a	130400-014 (7m)								
	2	2	2	2	2				



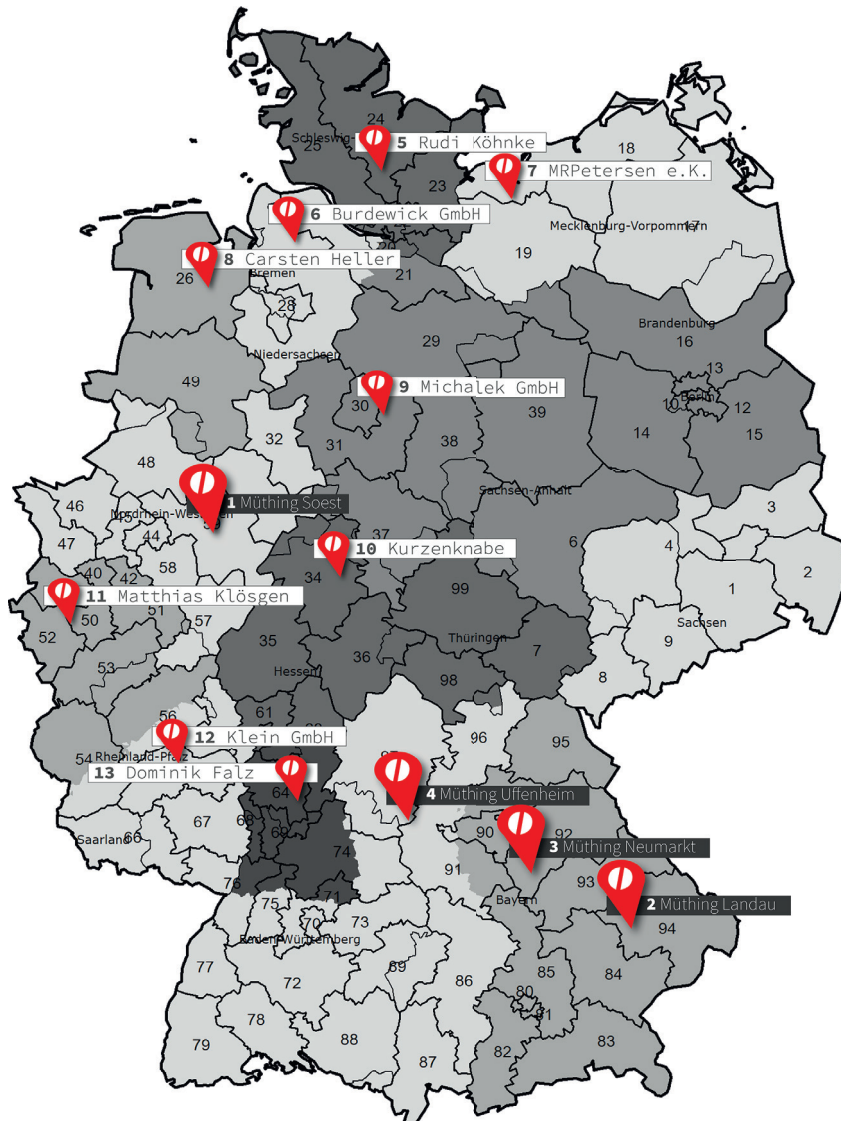

(1) Müthing GmbH & Co. KG Soest

Am Silberg 23
59494 Soest
Tel.: 02921 / 9651 - 0
Fax: 02921 / 73080
E-Mail: et-soest@muething.com

(2) Müthing GmbH & CO. KG Landau

Wiesenweg 6
94405 Landau
Tel.: 09951 / 6908 - 0
Fax: 09951 / 6333
E-Mail: et-landau@muething.com

(3) Müthing GmbH & Co. KG Neumarkt

Hans-Dehn-Str. 7
92318 Neumarkt
Tel.: 09181 / 2976 - 0
Fax: 09181 / 21841
E-Mail: neumarkt@muething.com

(4) Müthing GmbH & Co. KG Uffenheim

Am Brünlein 2
97215 Uffenheim
Tel.: 09842 / 9866 - 0
Fax: 09842 / 9866 - 67
E-Mail: et-uff@muething.com

(5) Rudi Köhnke

Wohldweg 16
24558 Henstedt-Ulzburg
Tel.: 04193 / 91544
Fax: 04193 / 759576
E-Mail: krkoehnke@aol.com

(6) Burdewick GmbH

Mittelstenaher Str. 33
21769 Lamstedt
Tel.: 04773 / 8941 - 0
Fax: 04773 / 8941 - 41
E-Mail: info@burdewick.de

(7) MRPetersen e.K. Werksvertretung

Christiansburger Weg 20
24969 Lindewitt / OT Sillerup
Tel.: 04604 / 9866 - 36
Fax: 04604 / 9866 - 37
E-Mail: rp@mrpetersen.de

(8) Müthing GmbH & Co. KG Soest - Carsten Heller Werksbeauftragter

Tel.: 0160 / 96919245
Fax: 04461 / 759302
E-Mail: c.heller@muething.com

(9) Michalek GmbH

Industriestraße 14
31275 Lehrte
Tel.: 05132 / 2006 - 0
Fax: 05132 / 2006 - 30
E-Mail: info@michalek-ww.de

(10) Kurzenknabe

Obervellmarer Weg 36
34314 Espenau
Tel.: 05673 / 4012
Fax: 05673 / 2495
E-Mail: info@kurzenknabe-gmbh.de

(11) Matthias Klösger

Drovestrasse 104
52372 Kreuzau
Tel.: 02422 / 9019 - 25
Fax: 02422 / 9019 - 26
E-Mail: matthias.kloesgen@t-online.de

(12) Klein GmbH

Hauptstraße 2
55627 Weiler / Nahe
Tel.: 06754 / 404
Fax: 06754 / 643
E-Mail: klein-ww-weiler@t-online.de

(13) Dominik Falz

Carl-Benz- Str. 4
64711 Erbach / Odw.
Tel.: 06062 / 1867
Fax: 06062 / 61851
E-Mail: d.falz@muething-mulcher.de

Bei weiteren Fragen zu Technik und Einsatz Ihres Gerätes stehen Ihnen unsere Mitarbeiter oder unsere Vertriebspartner gerne zur Verfügung.

Our employees or sales partners are happy to help should you have any further questions on the technical aspects and use of your implement.

Nos collaborateurs ou nos partenaires commerciaux sont à votre entière disposition pour toutes questions complémentaires relatives aux caractéristiques techniques ou à l'utilisation de votre engin.

Tanto nuestros empleados como los socios comerciales de la marca estamos a su disposición para atender cualquier consulta técnica o sobre piezas que pueda tener respecto a su equipo.

Blank page with horizontal dotted lines for writing.



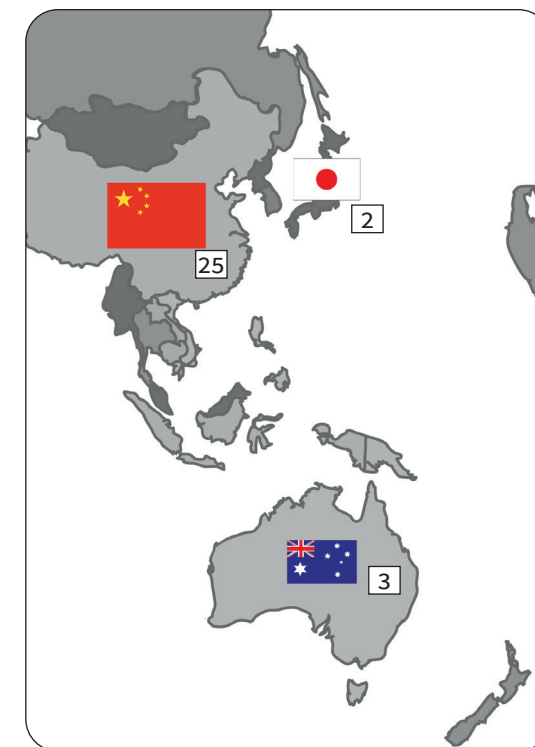

**(1) Prairie Agri Sales Ltd.**

W. Heidebrecht
P.O Box 216
Road 6W , 26028
Lowe Farm, MB R0G 1E0
Tel.: 001-204-746-6994
Fax: 001-204-515-4064
E-Mail: wheidebrecht@prairiegrisaes.ca

**(6) IP Innovations et Paysage**

ZI de Saint Nizier
F - 42190 Charlieu
Tel.: 0033 / 477 605454
Fax: 0033 / 477 606846
E-Mail: info@innovex-gmbh.de

**(11) Oy J-Trading Ab**

Kuriiritie 15
01510 Vantaa
Tel.: 00358 / 207458600
Fax: 00358 / 207458651
E-Mail: info@j-trading.fi

**(16) EZ Agrar e. Gen**

Salzburger Straße 38
4020 Linz
Tel.: 0043 / 732 347266
Fax: 0043 / 732 347260
E-Mail: office@ezagr.ar.at

**(21) Mühthng GmbH & Co. KG Soest**

Am Silberg 23
59494 Soest
Tel.: 02921 / 9651 -0
Fax: 02921 / 73080
E-Mail: et-soest@muething.com

**(2) Agri Direct Co. Ltd.**

Higashimemuro, Memuro-cho,
Kasai-gun
18-7 Kita 1-sen
Hokkaido 082-0004
Tel.: 0081 / 155612777
Fax: 0081 / 155612755
E-Mail: info@agridirect.jp

**(7) GTJ**

Peter Janssen
Way Broek 5
6041PJ Roermond
Tel.: 0031 / 615370411
E-Mail: p.janssen@gtjtrading.nl

**(12) Brøns Group**

Hovedvejen 20
6780 Skærbæk
Tel.: 0045 / 74753112
E-Mail: brons@bronsgroup.com

**(17) Güttler Mezőgazdasági**

Gépgyárto és Szolgá Kft.
Külterület 022/ 35
6800 Hódmezővásárhely
Tel.: 0036 / 62 533690
Fax: 0036 / 62 533691
E-Mail: orsolay.torok@guttler.hu

**(22) Mühthng GmbH & Co. KG Uffenheim**

Am Brunnlein 2
97215 Uffenheim
Tel.: 09842 / 9866 - 0
Fax: 09842 / 9866 -67
E-Mail: et-uff@muething.com

**(3) Southern Cross Mowers PTY Ltd.**

Marcus Cornish
1/29 Mustang Drive, PO Box 454
Rutherford NSW Australia 2320
Tel.: 0061 / 240440313
Fax: 0061 / 249321088
E-Mail: mcornish@sxm.com.au

**(8) Van Dyke Marcel Belgium**

Provinciebaan 71 - 2235 Houtvenne
Tel.: 0032 / 16699156
E-Mail: info@vandyck.be
GÖWEIL BNL PGmbH - Mirfeld
Zur Schmiede 23 - 4770 Amel
E-Mail: office@goeweil.be

**(13) Konekesko Eesti AS**

Pildiküla Rae vald
Porguvälja tee 3a
75308 Harjumaa MK
Tel.: 00372 / 6059100
Fax: 00372 / 6059101
E-Mail: kristjan.nelis@kesko.ee

**(18) Topagri S.r.o.**

Kostalkova 1527
26601 Beroun
Tel.: 00420 / 311 636766
Fax: 00420 / 311621822
E-Mail: topagri@topagri.cz

**(23) EZ Landmaschinen AG**

Bützbergstrasse 70
4912 Aarwangen
Tel.: 0041 / 62 9226801
Fax: 0041 / 62 9230369
E-Mail: info@ezlandmaschinen.ch

**(4) Simon Richard Ltd.**

Crown Tailrig
Simon Richardt
Bonchester Bridge
Hawick TD9 8RA
Tel.: 0044 / 1450860774
Fax: 0044 / 1450860772
E-Mail: mail@simon-richard.co.uk

**(9) Felten Freres et Fils Sarl**

Zone Artisanale
9775 Weicherdange
Tel.: 00352 921612
Fax: 00352 920530
E-Mail: info@felten.lu

**(14) SIA Konekesko Latvija**

Tiraines 15
1058 Riga
Tel.: 00371 / 67064300
Fax: 00371 / 67064301
E-Mail: aivars.metla-rozents@kesko.lv

**(19) Ematech s.r.o**

Piestanska 3/3
95605 Radosina
Tel.: 00421 / 385398119
Fax: 00421 / 385398216
E-Mail: ematech@ematech.sk

**(24) G.I.Antonakis A.E.**

3 xlm Thiva-Mouriki
32200 Thiva
Tel.: 0030 / 2262 025915
Fax: 0030 / 2262 025914
E-Mail: gianton@otenet.gr

**(5) Delgado Delgado e Hijos, S.A.**

C / Sevilla , 23
34004 Palencia
Tel.: 0034 / 979728450
Fax: 0034 / 979710390
E-Mail: recambios@deltacinco.es

**(10) ForSentralen AS**

Einar M. Bardal/ Carl M. Bardal
Bardalsvegen 100
7724 Steinkjer
Tel.: 0047 / 7414-7600
Fax: 0047 / 7414-9399
E-Mail: forsentralen@online.no

**(15) UAB Konekesko**

Vilniaus raj.
Moletu g. 13
14262 Didžioji Riese
Tel.: 00370 / 46421752
Fax: 00370 / 46421753
E-Mail: vilnius.sventkauskas@kesko.lt

**(20) NHR Agropartners SRL**

Judet Ilfov
Calea Bucurestilor 247
075100 Otopeni
Tel.: 0040 / 21 3007906
Fax: 0040 / 213521660
E-Mail: office@vait.ro

**(25) Ten Square International Inc. Nanjing**

Rm.402 Bldg.2, Zhongqing Plaza NO.96
Caochangmen St. Nanjing, Jiangsu
210013 China
Tel.: 0086 / 25 86210358
Fax: 0086 / 25 86212081
E-Mail: usoffice@tensquareintl.com

A large rectangular area filled with horizontal dotted lines, intended for handwritten notes or text.

Blank lined page for notes.





Müthing GmbH & Co. KG Soest
Am Silberberg 23
59494 Soest

Tel +49 (0) 2921 96510
Fax +49 (0) 2921 73080
soest@muething.com

Müthing GmbH & Co. KG Uffenheim
Am Brünlein 2
97215 Uffenheim

Tel +49 (0) 9842 98660
Fax +49 (0) 9842 98667
uffenheim@muething.com

WWW.MUETHING.COM