



ERSATZTEILLISTE | Spare parts list
Liste des pièces de rechange | Lista de repuestos

MU-E-HY VARIO 140 - 200

AB SERIE | as of series | á partir de série | desde de la serie 2019

AUSGABE | edition | version | edición 10.2020

ARTIKELNUMMER | article number | numéro d'article | número de artículo MU-E-HY_ET_19_2020-09

Übertragen Sie hier bitte die Daten Ihres Gerätes und des verwendeten Getriebes.

Enter the details for your implement and the gear box you are using here.

Veuillez inscrire ici les références de votre machine et celles du boîtier.

Introduzca aquí los datos de su equipo y la transmisión utilizada.

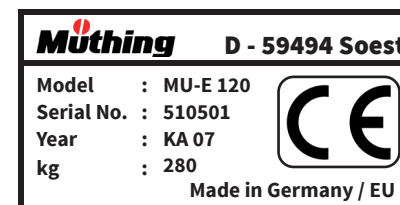

*Beispiel Typenschild | Type plate example
Exemple de plaque signalétique | Ejemplo de una placa de características*

Benennung Designation Désignation Designación	Eintrag Entry N° d'enregistrement Registro
Modell Model Modèle Modelo	MU-E-HY VARIO 140 - 200 <input type="checkbox"/> 140 <input type="checkbox"/> 160 <input type="checkbox"/> 180 <input type="checkbox"/> 200
Seriennummer Serial number N° de série Número de serie	
Baujahr Year of manufacture Année de construction Año de construcción	
Getriebetyp Gearbox type Type de Système d'entraînement Tipo de transmisión	
Anbaubock Headstock Attelage Soporte adosado	<input type="checkbox"/> fest fixed fixe fijo <input type="checkbox"/> verschiebbar movable déportable móvil
Händler Dealer Distributeur Concesionario	
Inbetriebnahme am Commissioning date Date de mise en service Fecha de puesta en servicio	

Bei bitte deutlich ankreuzen !

Where there are checkboxes , please check these clearly!

Veuillez cocher les cases lisiblement!

Por favor, marque con una cruz en la casilla .



20 horizontal dotted lines for writing.



Einleitung Introduction Introduction Introducción 	6
Gerätebeschreibung Device description Description de l'appareil Description del dispositivo 	7
Grundausführung Basic model Modèle de base Modelo básico 	
Gehäuse Housing Carter Caja 	8
Kurzhäckselleiste Short chopping bar Lame hache-paille courte Listón de corte de paja corto 	14
Anbaubock Front Front Headstock Tête d'attelage avant Soporte adosado delante 	16
Hydro Antrieb Hydraulic drive Entraînement hydraulique Accionamiento hidráulico 	20
Hydraulikantrieb Übersetzung Hydraulic drive ratio Rapport de démultiplication hydraulique Relación de transmisión hidráulica 	24
Schäkelrotor Shackle rotor Rotor manilles Rotor del grillete 	26
Stützwalze Support roller Rouleau d'appui Cilindro de apoyo 	30
Sonderzubehör Optional accessory Accessoires optionnels Componente especial 	
Stützrad Support wheel Roue d'appui Rueda de soporte 	34
Heck Stützrad Rear Support wheel Roue d'appui arrière Rueda de soporte detrás 	36
Anbaudreieck Kat.1 Implement triangle Kat.1 Triangle d'attelage Kat.1 Triángulo del dispositivo Kat.1 	38
Anbaudreieck Kat.1N Implement triangle Kat.1N Triangle d'attelage Kat.1N Triángulo del dispositivo Kat.1N 	40
Kurzschnittklappe Short-cut flap Clapet de coupe courte Tapa de corte corto 	42
Hydraulische Seitenverschiebung Hydraulic side shift Déport latéral hydraulique Desplazamiento lateral hidráulico 	44
Schneidschiene Cutting bar Contre-Lame Réglable Carril de corte 	48
Verschleißeinlage Wear insert Intercalaire anti-usure Junta de desgaste 	50
Verschleißkufen Wear runner Patin d'usure Cuchilla de desgaste 	52
Hydraulische Druckentlastung MU-SOFA Hydraulic pressure relief MU-SOFA Délestage hydraulique MU-SOFA Descarga de presión hidráulica MU-SOFA 	54
Betriebsstundenzähler Operating hours counter Compteur horaire Contador de horas de servicio 	58
Beleuchtungsträger Lighting equipment Support d'éclairage Soporte de alumbrado 	60
Warntafel mit Beleuchtungseinrichtung Warning sign with lighting equipment Panneau de signalisation avec système d'éclairage Panel de aviso con dispositivo de iluminación 	62

20 horizontal dotted lines for writing.



SEHR GEEHRTER KUNDE,

auf den folgenden Seiten finden Sie eine vollständige Übersicht aller Bauteile Ihres Müthing Mulchgerätes MU-E-HY VARIO 140 - 200. Anhand dieser Unterlage bitten wir Sie benötigte Ersatzteile genau zu identifizieren und mit den nachfolgenden Angaben zu bestellen. Benötigen Sie Hilfe oder weitere Informationen kontaktieren Sie uns.

Vielen Dank - Ihr Müthing-Team

CHER CLIENT,

Vous trouverez sur les pages suivantes une description complète des composants de votre broyeur Müthing MU-E-HY VARIO 140 - 200. Nous vous invitons à identifier exactement les pièces de rechange requises à l'appui de ce document et de les commander en indiquant le n° de référence de pièces de rechange. N'hésitez pas à nous contacter si vous avez besoin d'aide ou d'informations complémentaires.

Merci beaucoup – Votre équipe Müthing

DEAR CUSTOMER,

The following pages offer a complete overview of the components in your Müthing MU-E-HY VARIO 140 - 200 mulcher. We are providing you with this document so that you can identify exactly the spare parts you require and order them using the spare part numbers listed. Should you need any assistance or further information, please contact us.

Kind regards - Your Müthing team

ESTIMADO CLIENTE,

En las siguientes páginas ponemos a su disposición una relación completa de los componentes de su trituradora MU-E-HY VARIO 140 - 200 de Müthing. Le rogamos que con ayuda de este listado identifique las piezas de repuesto necesarias y las encargue con su correspondiente número de repuesto. No dude en ponerse en contacto con nosotros para solicitar ayuda o información ampliada.

Muchas gracias - Su equipo Müthing



Beachten Sie immer die Sicherheitshinweise der Betriebsanleitung !

Always follow the safety instructions in the operating manual.

Veuillez toujours tenir compte des consignes de sécurité figurant dans le manuel d'utilisation !

Observe siempre las indicaciones de seguridad de las instrucciones de servicio !

DIE HAUPTBAUGRUPPEN SIND:

1. Mulchergehäuse mit Schutzlamellen, hinterem Gummischutz und Gleitkufen
2. Dreipunktanbaubock
3. Rotor mit Lagerung, Werkzeugen und Werkzeughaltern
4. Stützwalze (Stützräder) mit Lagerung
5. Hydro Antrieb mit Keilriemenschutzhaube
6. Sonderzubehör

LES GROUPES PRINCIPAUX SONT:

1. Carter du broyeur avec lamelles de protection, protection en caoutchouc à l'arrière et patins de glissement
2. Attelage trois points
3. Rotor équilibré avec outils et supports d'outils
4. Rouleau-support (roues supports) avec suspension
5. Entraînement hydraulique avec capot de protection
6. Accessoires spécifiques

THE MAIN COMPONENTS ARE:

1. Mulcher housing with protective strips, rear rubber protector and skids
2. Three-point headstock
3. Rotor with mount, tools and tool holders
4. Support roller (support wheels) with mount
5. Hydraulic drive with V-belt guard
6. Optional accessories

LOS GRUPOS CONSTRUCTIVOS PRINCIPALES SON:

1. Carcasa de la trituradora con placas de protección, protección trasera de goma y patines
2. Enganche de tres puntos
3. Rotor con cojinete, herramientas y portaherramientas
4. Cilindro de apoyo (ruedas de apoyo) con cojinete
5. Accionamiento hidráulico con cubierta protectora de la correa
6. Accesorio especial



| Hauptbaugruppe Schlegelmulcher Baureihe MU-E-HY VARIO 140 - 200

| Main assembly of the MU-E-HY VARIO 140 - 200 flail mulcher

| Groupe principal Broyeur à marteaux série MU-E-HY VARIO 140 - 200

| Grupo constructivo desbrozadora serie MU-E-HY VARIO 140 - 200

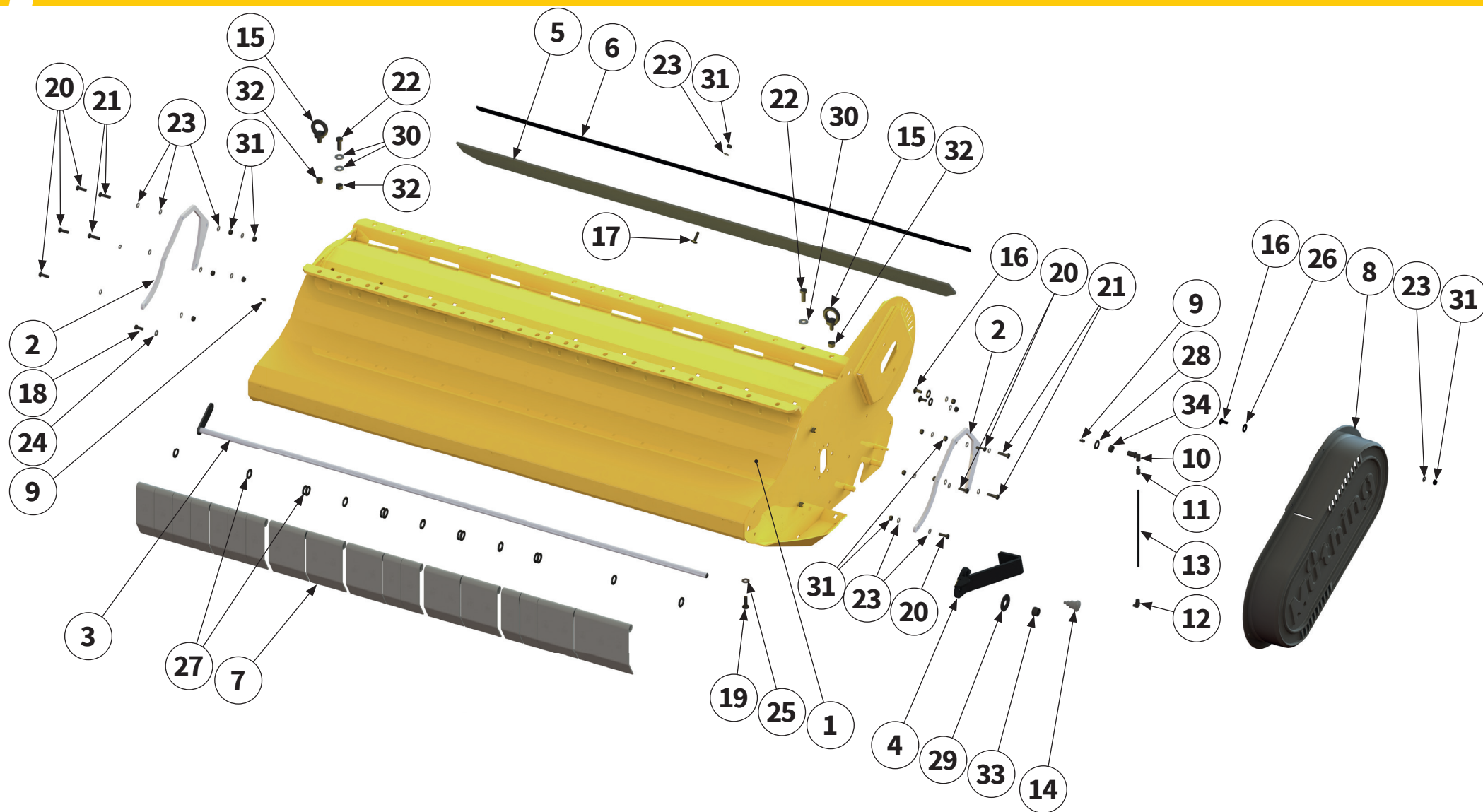

Pos.-Nr. No. Número	Ersatzteilnummer Manufacturer part number Numéro de pièce du fabricant Número de pieza del fabricante				DE Bezeichnung	EN Designation	FR Désignation	ES Designación
	Anzahl quantity quantité número							
	MU-E 140	MU-E 160	MU-E 180	MU-E 200				
1	00017402 1	00017171 1	00017361 1	00017120 1	Gehäuse	housing	Carter	Caja
2	00015256 2				Blech	sheet metal	Tôle	Chapa
3	00017380 1	00017173 1	00017347 1	00017112 1	Pendelwelle	swing shaft	Arbre oscillant	Eje del péndulo
4	00017060 1				Stütze	support	Support	Apoyo
5	00003524 1	00003519 1	00017348 1	00015266 1	Schutzgummi	protective rubber	Protection	Goma protectora
6	00003523 1	00003518 1	00017338 1	00015244 1	Klemmleiste	clamping strip	Tôle de support	Barra de conexión
7	MU000313-1 23				Pendelschutz- klappe	flap with swing protection	Volet de protection oscillant	Tapa protectora del péndulo
8	00017121 1				Schutz- abdeckung	protective cover	Recouvrement de protection	Cubierta protectora
9	DIN71412A-H1-M08X1 2				Schmiernippel	lubricating nipple	Nipple de graissage	Engrasador
10	00017522 1				Winkelverbinder	elbow connector	Connecteur d'angle	Escuadra de unión
11	MULI0002 1				Verschraubung	threaded connection	Raccord à vis	Unión atornillada
12	MULI0006 1				Verschraubung	threaded connection	Raccord à vis	Unión atornillada
13	MULI0005 0,25m				Schmierleitung	lubrication line	Conduite de graissage	Tubería de engrase
14	00017113 1				Rastbolzen	stop bolt	Boulon d'arrêt	Perno de retención

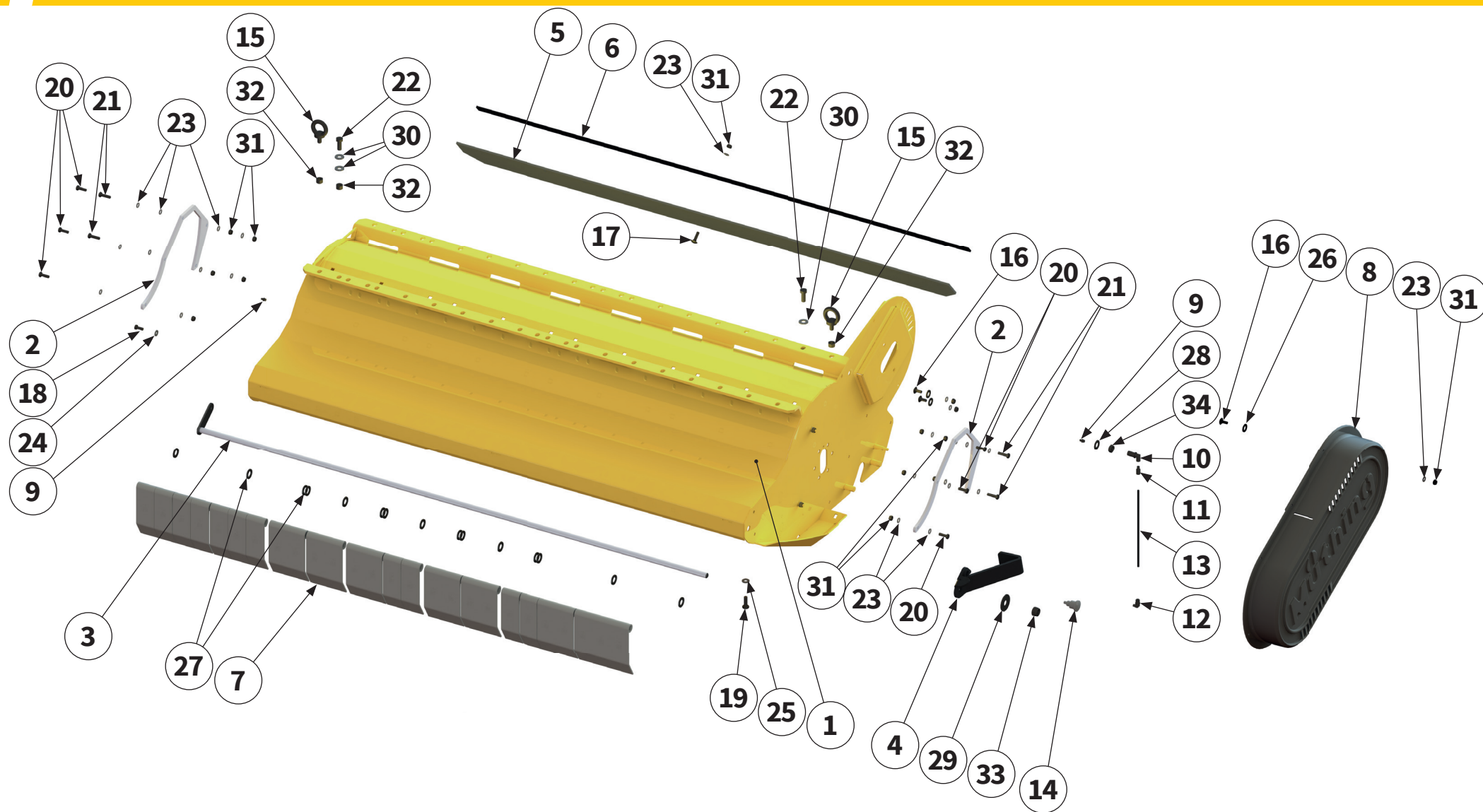

Pos.-Nr. No. Número	Ersatzteilnummer Manufacturer part number Numéro de pièce du fabricant Número de pieza del fabricante				DE Bezeichnung	EN Designation	FR Désignation	ES Designación
	Anzahl quantity quantité número							
	MU-E 140	MU-E 160	MU-E 180	MU-E 200				
15	00008092				Ringschraube	ring bolt	Vis à œillet	Armella
	2	2	2	2				
16	MU980107				Schraube	bolt	Vis	Tornillo
	3	3	3	3				
17	MU0099987				Schraube	bolt	Vis	Tornillo
	11	13	13	15				
18	MU980115				Schraube	bolt	Vis	Tornillo
	1	1	1	1				
19	MU980205				Schraube	bolt	Vis	Tornillo
	13	17	19	21				
20	MU980109				Schraube	bolt	Vis	Tornillo
	6	6	6	6				
21	MU0099908				Schraube	bolt	Vis	Tornillo
	4	4	4	4				
22	MU980307				Schraube	bolt	Vis	Tornillo
	2	2	2	2				
23	MU0099999				Scheibe	washer	Disque	Arandela
	34	38	38	42				
24	MUNSKL08				Scheibe	washer	Disque	Arandela
	1	1	1	1				
25	MUNSKL10				Scheibe	washer	Disque	Arandela
	13	17	19	21				
26	MU980302				Scheibe	washer	Disque	Arandela
	3	3	3	3				
27	MU980402				Scheibe	washer	Disque	Arandela
	15	15	2	8				



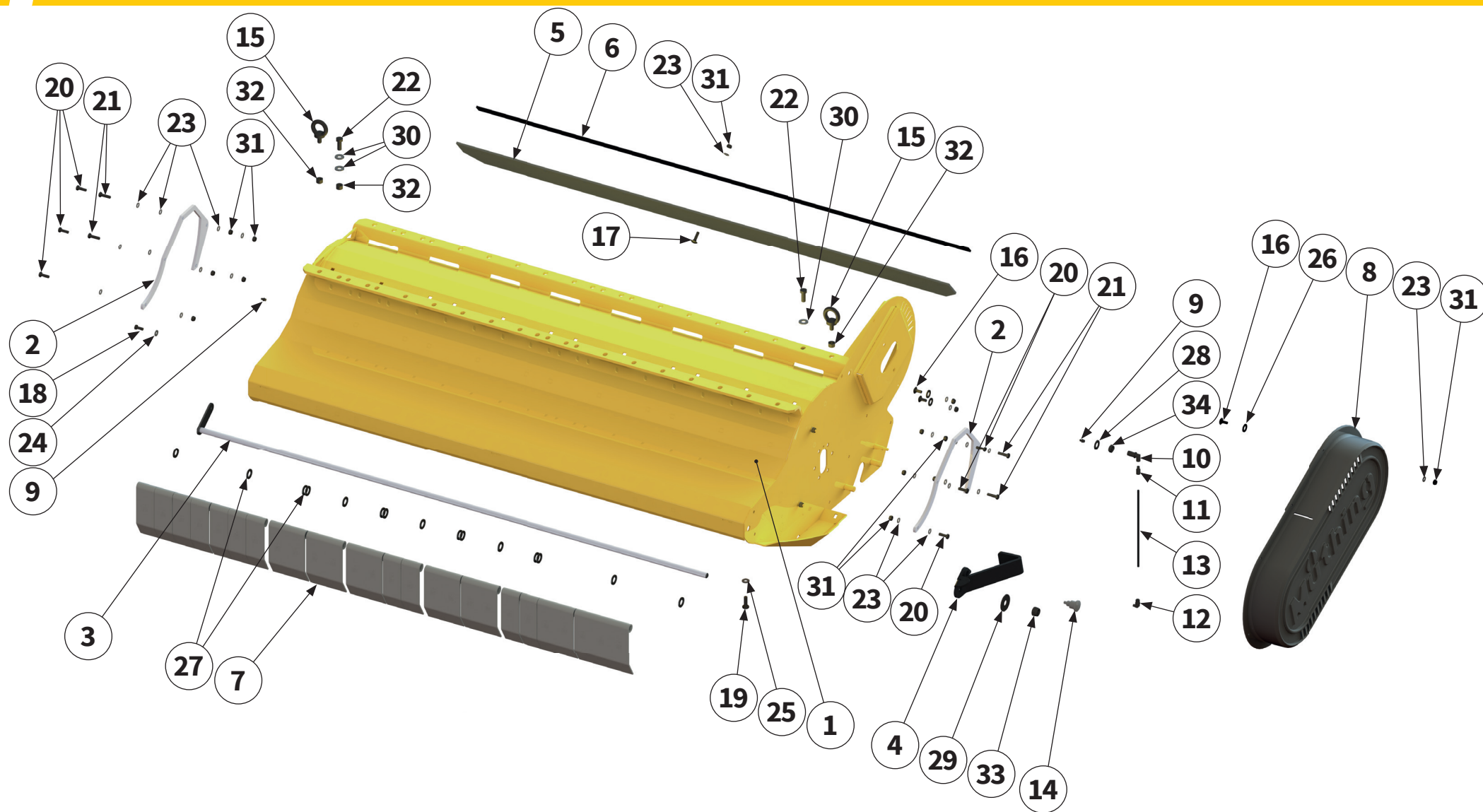

Pos.-Nr. No. Numéro Número	Ersatzteilnummer Manufacturer part number Numéro de pièce du fabricant Número de pieza del fabricante				DE Bezeichnung	EN Designation	FR Désignation	ES Designación
	Anzahl quantity quantité número							
	MU-E 140	MU-E 160	MU-E 180	MU-E 200				
28	MU980502				Scheibe	washer	Disque	Arandela
	1	1	1	1				
29	MU980403				Scheibe	washer	Disque	Arandela
	1	1	1	1				
30	MUNSKL12				Scheibe	washer	Disque	Arandela
	4	4	4	4				
31	MU0099961				Mutter	nut	Écrou	Tuerca
	26	28	28	30				
32	MU980301				Mutter	nut	Écrou	Tuerca
	4	4	4	4				
33	MU980401				Mutter	nut	Écrou	Tuerca
	1	1	1	1				
34	MU980521				Mutter	nut	Écrou	Tuerca
	1	1	1	1				



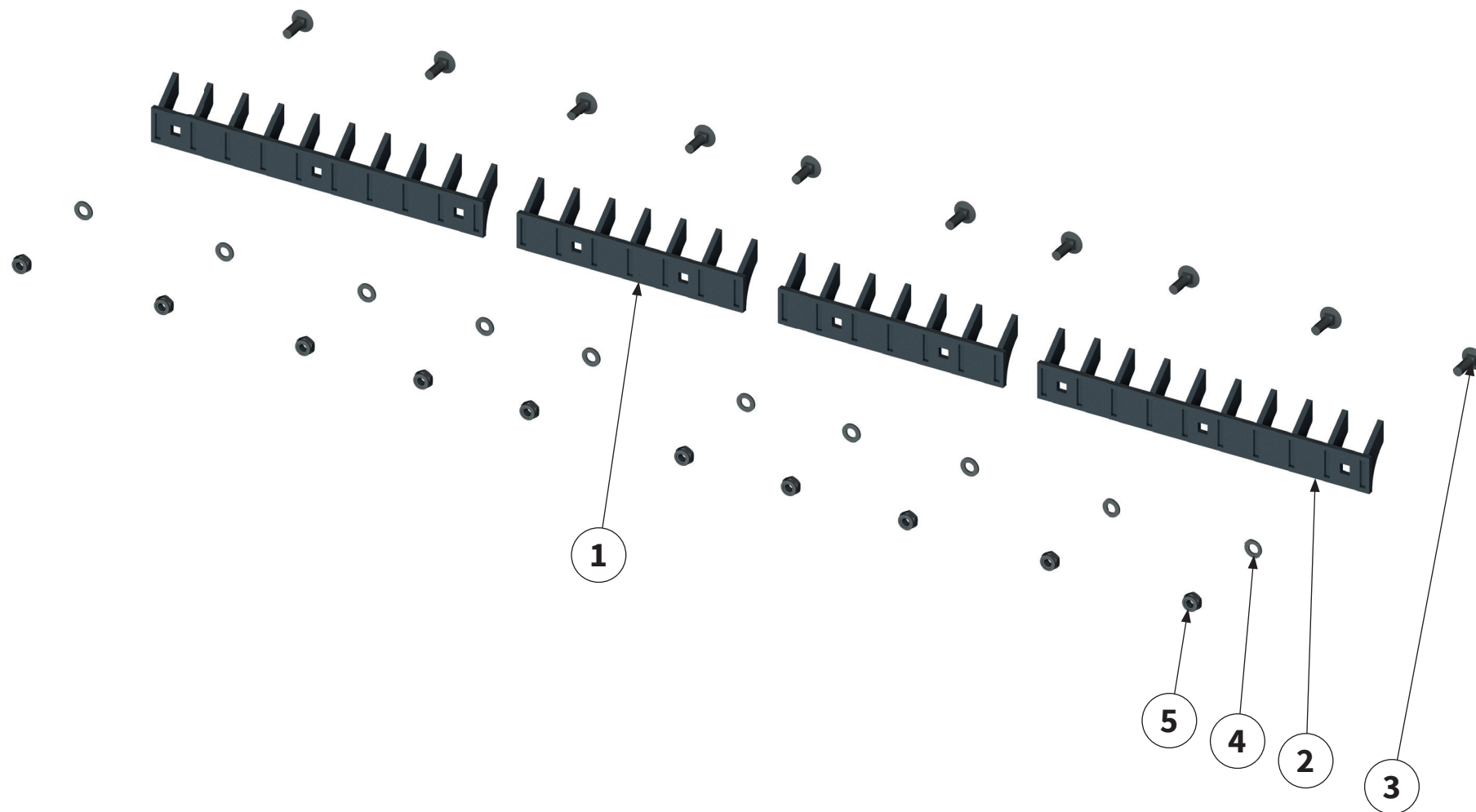

Pos.-Nr. No. Numéro Número	Ersatzteilnummer Manufacturer part number Numéro de pièce du fabricant Número de pieza del fabricante				DE Bezeichnung	EN Designation	FR Désignation	ES Designación
	Anzahl quantity quantité número							
	MU-E 140	MU-E 160	MU-E 180	MU-E 200				
1	00005516				Gegenschneide 300	shear bar	Lame hache-paille courte	Contracuchilla
	2	-	2	-				
2	00005518				Gegenschneide 400	shear bar	Lame hache-paille courte	Contracuchilla
	2	4	3	5				
3	00000904				Schraube	bolt	Vis	Tornillo
	10	12	13	15				
4	MU980202				Scheibe	washer	Disque	Arandela
	10	12	13	15				
5	MU0099960				Mutter	nut	Écrou	Tuerca
	10	12	13	15				



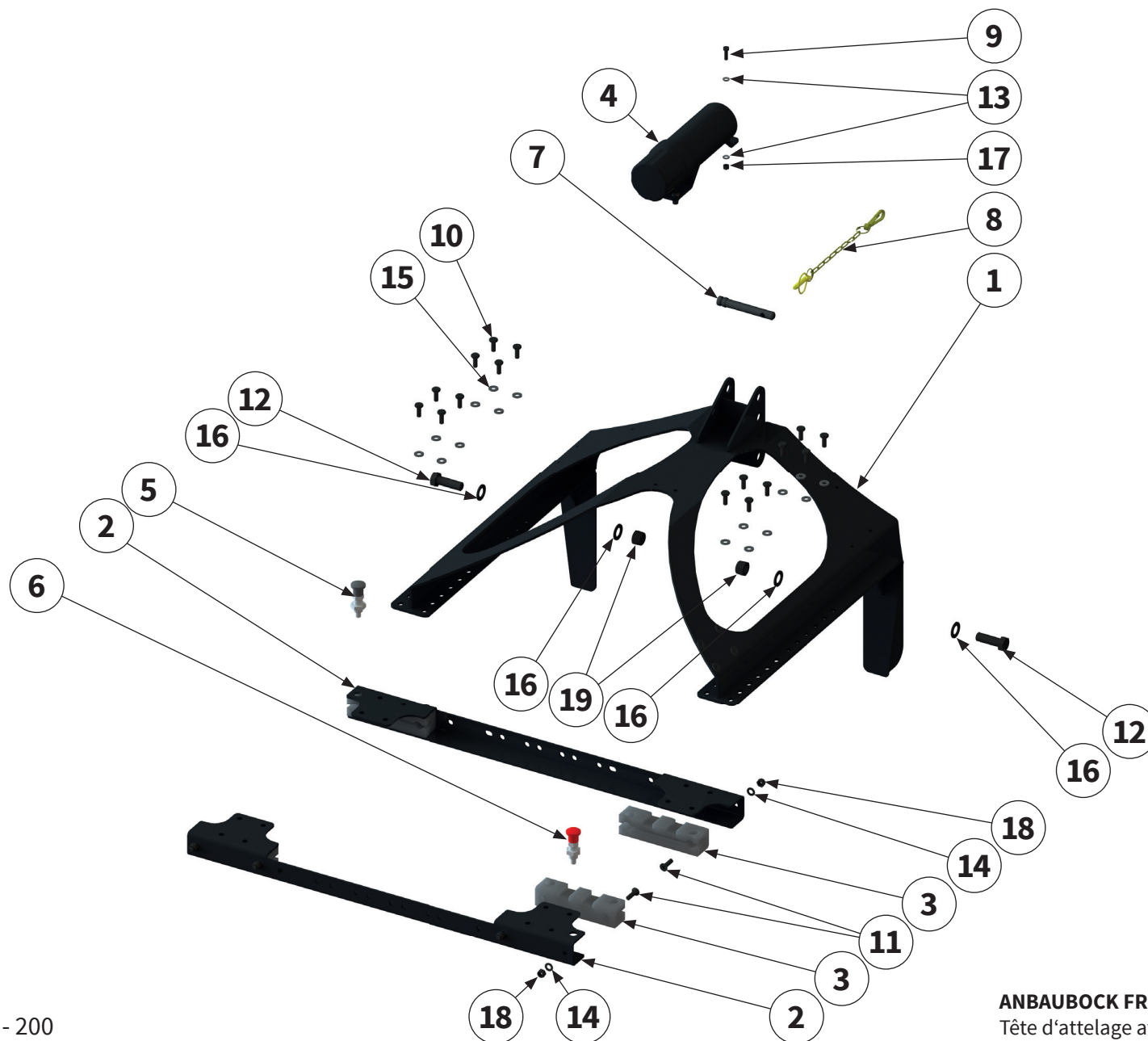

Pos.-Nr. No. Número	Ersatzteilnummer Manufacturer part number Numéro de pièce du fabricant Número de pieza del fabricante				DE Bezeichnung	EN Designation	FR Désignation	ES Designación
	Anzahl quantity quantité número							
	MU-E 140	MU-E 160	MU-E 180	MU-E 200				
1	00017130				Anbaubock	headstock	Tête d'attelage	Soporte adosado
	1	1	1	1				
2	00015845				Gleitschieneaufnahme	slide bar holder	Logement d' rail de glissement	Alojamiento del riel de deslizamiento
	2	2	2	2				
3	00015846				Gleitplatte	slide plate	Plaque de glissement	Placa deslizante
	2	2	2	2				
4	00034497				Dokumentenrolle	document roll	Document rouleau	Rollo de documento
	1	1	1	1				
5	00015865				Rastbolzen	stop bolt	Boulon d'arrêt	Perno de retención
	1	1	1	1				
6	00031524				Rastbolzen	stop bolt	Boulon d'arrêt	Perno de retención
	1	1	1	1				
7	MU0205041				Oberlenkerbolzen	upper link pin	Boulon de liaison supérieure	Perno del brazo superior
	1	1	1	1				
8	MU2500106				Kette	chain	Chaîne	Cadena
	1	1	1	1				
9	MU980109				Schraube	bolt	Vis	Tornillo
	3	3	3	3				
10	MU980208				Schraube	bolt	Vis	Tornillo
	16	16	16	16				
11	MU980251				Schraube	bolt	Vis	Tornillo
	8	8	8	8				
12	MU981008				Schraube	bolt	Vis	Tornillo
	2	2	2	2				
13	MU0099999				Scheibe	washer	Disque	Arandela
	6	6	6	6				

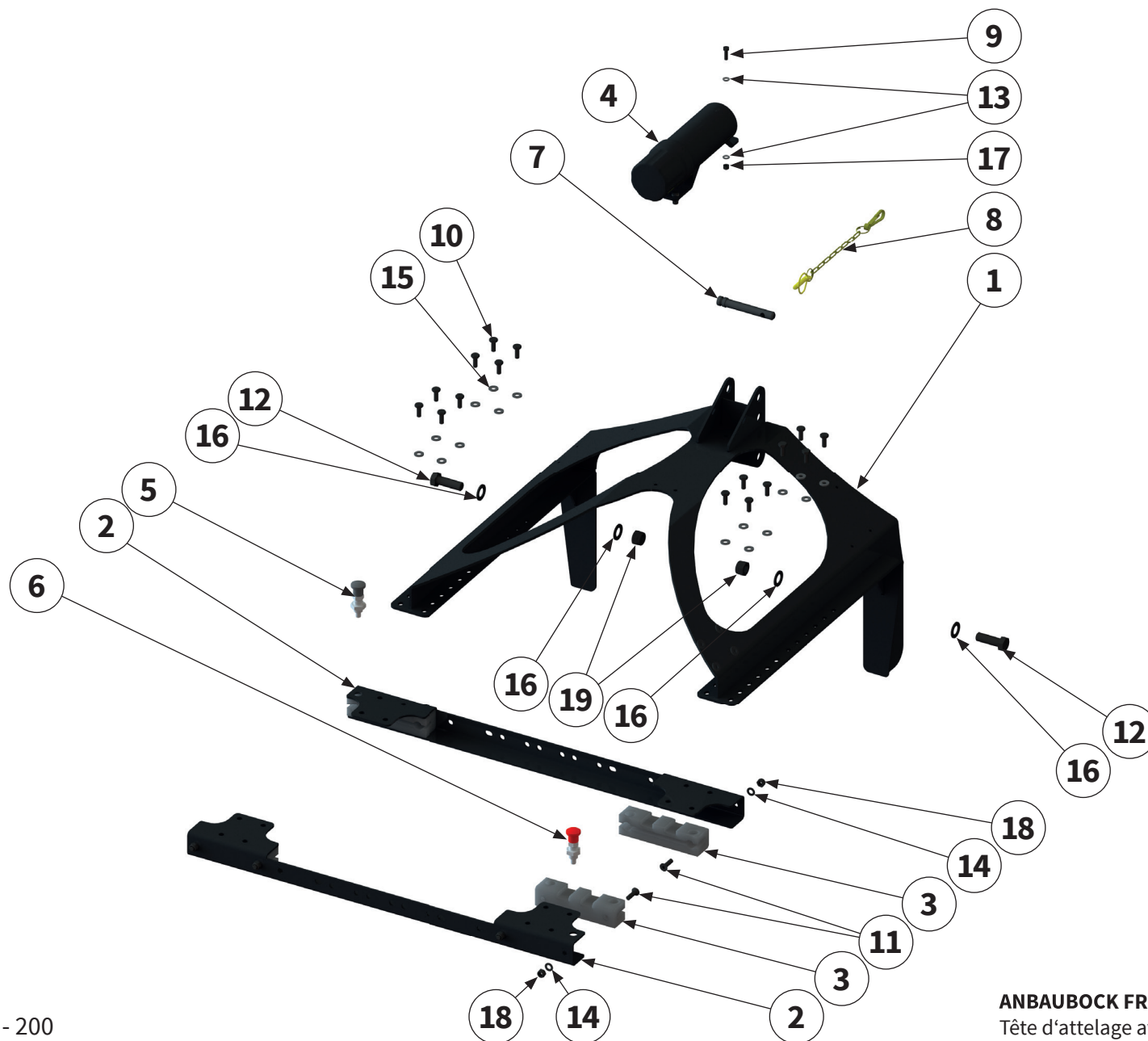

ANBAUBOCK FRONT | Front Headstock |
Tête d'attelage avant | Soporte adosado delante |

Pos.-Nr. No. Numéro Número	Ersatzteilnummer Manufacturer part number Numéro de pièce du fabricant Número de pieza del fabricante				DE Bezeichnung	EN Designation	FR Désignation	ES Designación
	Anzahl quantity quantité número							
	MU-E 140	MU-E 160	MU-E 180	MU-E 200				
14	MU980202				Scheibe	washer	Disque	Arandela
	8	8	8	8				
15	MUNSLK10				Scheibe	washer	Disque	Arandela
	16	16	16	16				
16	MU980505				Scheibe	washer	Disque	Arandela
	4	4	4	4				
17	MU0099961				Mutter	nut	Écrou	Tuerca
	3	3	3	3				
18	MU0099960				Mutter	nut	Écrou	Tuerca
	8	8	8	8				
19	MU0099959				Mutter	nut	Écrou	Tuerca
	2	2	2	2				

Pos.-Nr. No. Número	Ersatzteilnummer Manufacturer part number Numéro de pièce du fabricant Número de pieza del fabricante				DE Bezeichnung	EN Designation	FR Désignation	ES Designación
	Anzahl quantity quantité número							
	MU-E 140	MU-E 160	MU-E 180	MU-E 200				
1	00014772				Spannblech	clamping plate	Plaque de serrage	Chapa de sujeción
	1	1	1	1				
2	00015680				Zahnradmotor	hydraulic motor	Moteur hydraulique	Motor hidráulico
	1	1	1	1				
	Volumina volume volume el volumen = 20 ccm/U							
2a	00017440				Zahnradmotor	hydraulic motor	Moteur hydraulique	Motor hidráulico
	1	1	1	1				
	Volumina volume volume el volumen = 26 ccm/U							
3	00015678				Lager	bearing	Palier	Rodamiento
	1	1	1	1				
4	MUDM0004				Dichtsatz	sealpacket	Kit d'étanchéité	Juego de estanqueización
	1	1	1	1				
5	00015682				Flansch	flange	Bride	Brida
	1	1	1	1				
6	00015684				Flansch	flange	Bride	Brida
	1	1	1	1				
7	00015668				Verschraubung	threaded connection	Raccord à vis	Unión atornillada
	1	1	1	1				
8	00015669				Verschraubung	threaded connection	Raccord à vis	Unión atornillada
	1	1	1	1				
9	00015796				Hydraulikschlauch	hydraulic hose	Tuyau hydraulique	Tubo flexible hidráulico
	1	1	1	1				
10	00015799				Hydraulikschlauch	hydraulic hose	Tuyau hydraulique	Tubo flexible hidráulico
	1	1	1	1				
11	MU981036				Schraube	bolt	Vis	Tornillo
	2	2	2	2				
12	MU981133				Schraube	bolt	Vis	Tornillo
	2	2	2	2				

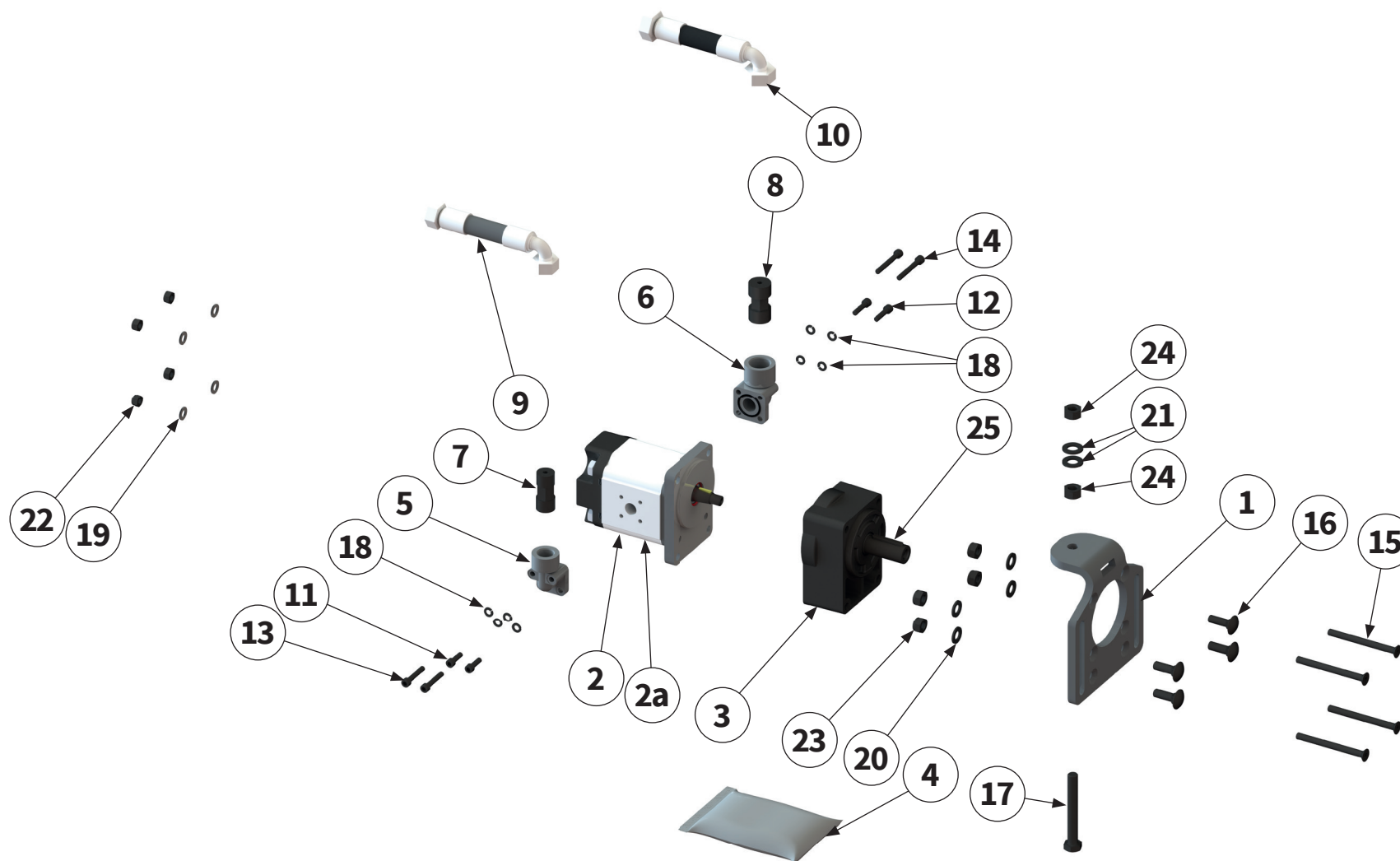

Pos.-Nr. No. Número	Ersatzteilnummer Manufacturer part number Numéro de pièce du fabricant Número de pieza del fabricante				DE Bezeichnung	EN Designation	FR Désignation	ES Designación
	Anzahl quantity quantité número							
	MU-E 140	MU-E 160	MU-E 180	MU-E 200				
13	MU981134				Schraube	bolt	Vis	Tornillo
	2	2	2	2				
14	MU981135				Schraube	bolt	Vis	Tornillo
	2	2	2	2				
15	00008123				Schraube	bolt	Vis	Tornillo
	4	4	4	4				
16	00000904				Schraube	bolt	Vis	Tornillo
	4	4	4	4				
17	MU980316				Schraube	bolt	Vis	Tornillo
	1	1	1	1				
18	MU981052				Scheibe	washer	Disque	Arandela
	8	8	8	8				
19	MU0099999				Scheibe	washer	Disque	Arandela
	4	4	4	4				
20	MU980202				Scheibe	washer	Disque	Arandela
	4	4	4	4				
21	MU980302				Scheibe	washer	Disque	Arandela
	2	2	2	2				
22	MU0099961				Mutter	nut	Écrou	Tuerca
	4	4	4	4				
23	MU0099960				Mutter	nut	Écrou	Tuerca
	4	4	4	4				
24	MU980300				Mutter	nut	Écrou	Tuerca
	2	2	2	2				
25	00008108				Passfeder	parallel key	Clavette	Chaveta de ajuste
	1	1	1	1				



Pos.-Nr. No. Numéro Número	Ersatzteilnummer Manufacturer part number Numéro de pièce du fabricant Número de pieza del fabricante								DE Bezeichnung	EN Designation	FR Désignation	ES Designación
	Volumenstrom Fahrzeug Vehicle volume flow rate Débit volumique véhicule Caudal vehículo											
	50 l/min	55 l/min	60 l/min	65 l/min	70 l/min	75 l/min	80 l/min	90 l/min				
1	MU981913 1	MU981910 1	MU981911 1	MU981913 1	MU981910 1	MU981911 1	MU981909 1	00017144 1	Keilriemen- scheibe	belt pulley	Poulie	Polea
2	00017144 1	MU981909 1	MU981911 1	000017144 1	MU981909 1	MU981911 1	MU981910 1	MU981913 1	Keilriemen- scheibe	belt pulley	Poulie	Polea
3	00009138 1				00008140 1				Spannbuchse	clamping bush	Douille de serrage	Manguito de sujeción
4	00005570 1		MU980829 1	00005570 1		MU980829 1			Spannbuchse	clamping bush	Douille de serrage	Manguito de sujeción
5	MU980827 2		00014143 2	MU980827 2		00017143 2	MU980827 2		Keilriemen	V-belt	Courroie trapézoïdale	Correa trape- zoidal



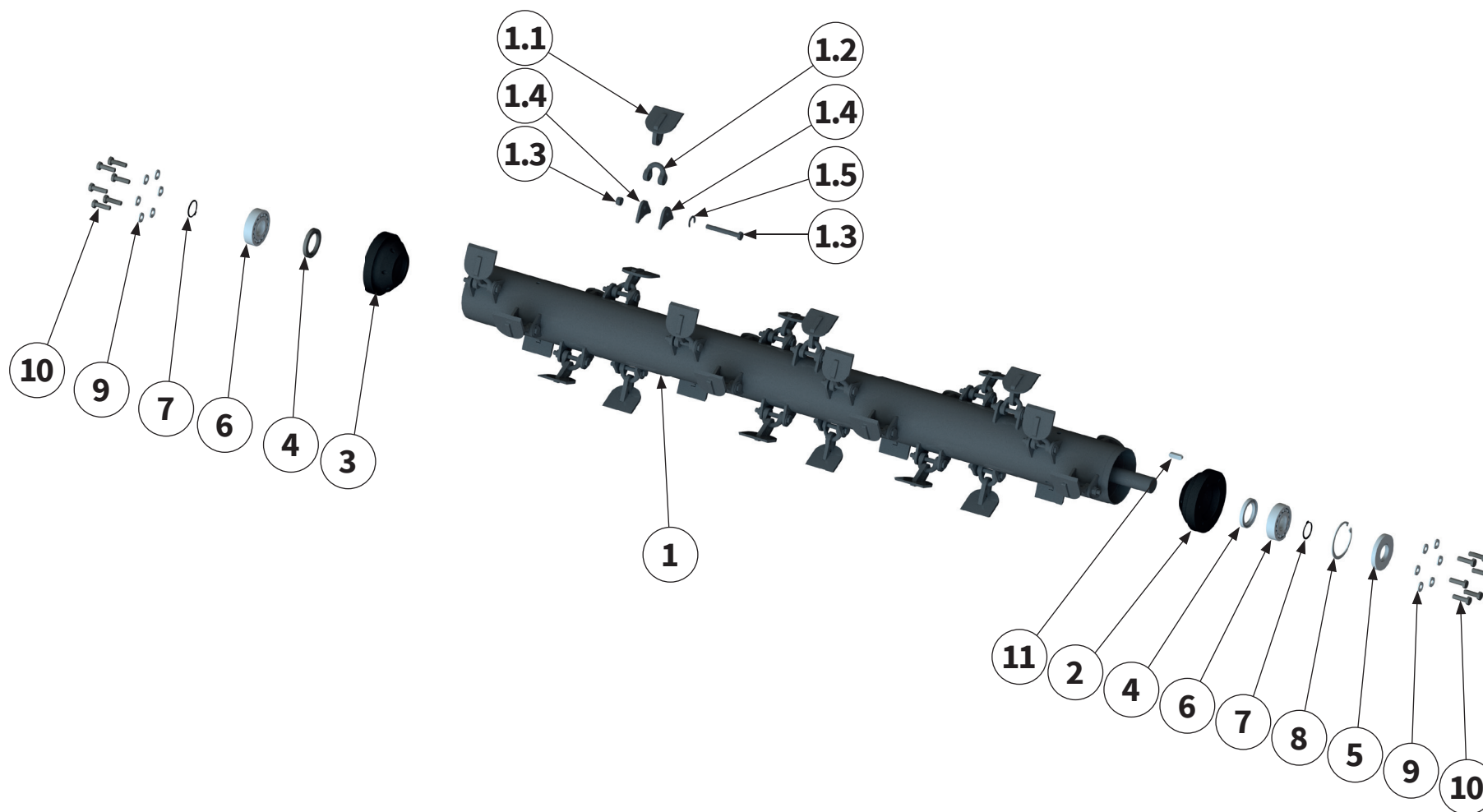

Pos.-Nr. No. Número	Ersatzteilnummer Manufacturer part number Numéro de pièce du fabricant Número de pieza del fabricante				DE Bezeichnung	EN Designation	FR Désignation	ES Designación
	Anzahl quantity quantité número							
	MU-E 140	MU-E 160	MU-E 180	MU-E 200				
1	00017384 1	00017078 1	00017236 1	00015218 1	Rotor inkl. Werkzeug	rotor with tools	Rotor avec outils	Rotor con herram
1.1	MU4				Schäkelmesser	shackle flail	Lame de manille	Chuchilla del grillete
	24	28	32	36				
1.2	MU0801031				Schäkel	shackle	Manille	Grillete
	24	28	32	36				
1.3	MU0801041				Schraube mit Mut- ter	bolt with nut	Vis avec Écrou	Tornillo con Tuerca
	24	28	32	36				
1.4	00015026				Werkzeughalter	tool holder	Porte-outil	Portaherramientas
	48	56	64	72				
1.5	MU0702051				Verdrehsicherung	anti-twist protection	Sécurité anti-torsion	Seguro contra giro
	24	28	32	36				
2	00015217				Rotorhalterung	rotor holder	Support de rotor	Soporte del rotor
	1	1	1	1				
3	00015216				Rotorhalterung	rotor holder	Support de rotor	Soporte del rotor
	1	1	1	1				
4	MU981101				Wellendichtring	shaft sealing ring	Baque à lèvres	Retén de eje
	2	2	2	2				
5	MU623007				Wellendichtring	shaft sealing ring	Baque à lèvres	Retén de eje
	1	1	1	1				
6	MU981102				Wälzlager	roller bearing	Palier à roulement	Rodamiento
	2	2	2	2				
7	MU490009				Sicherungsring	circlip	Bague de sécurité	Anillo de seguridad
	2	2	2	2				
8	MU981896				Sicherungsring	circlip	Bague de sécurité	Anillo de seguridad
	1	1	1	1				

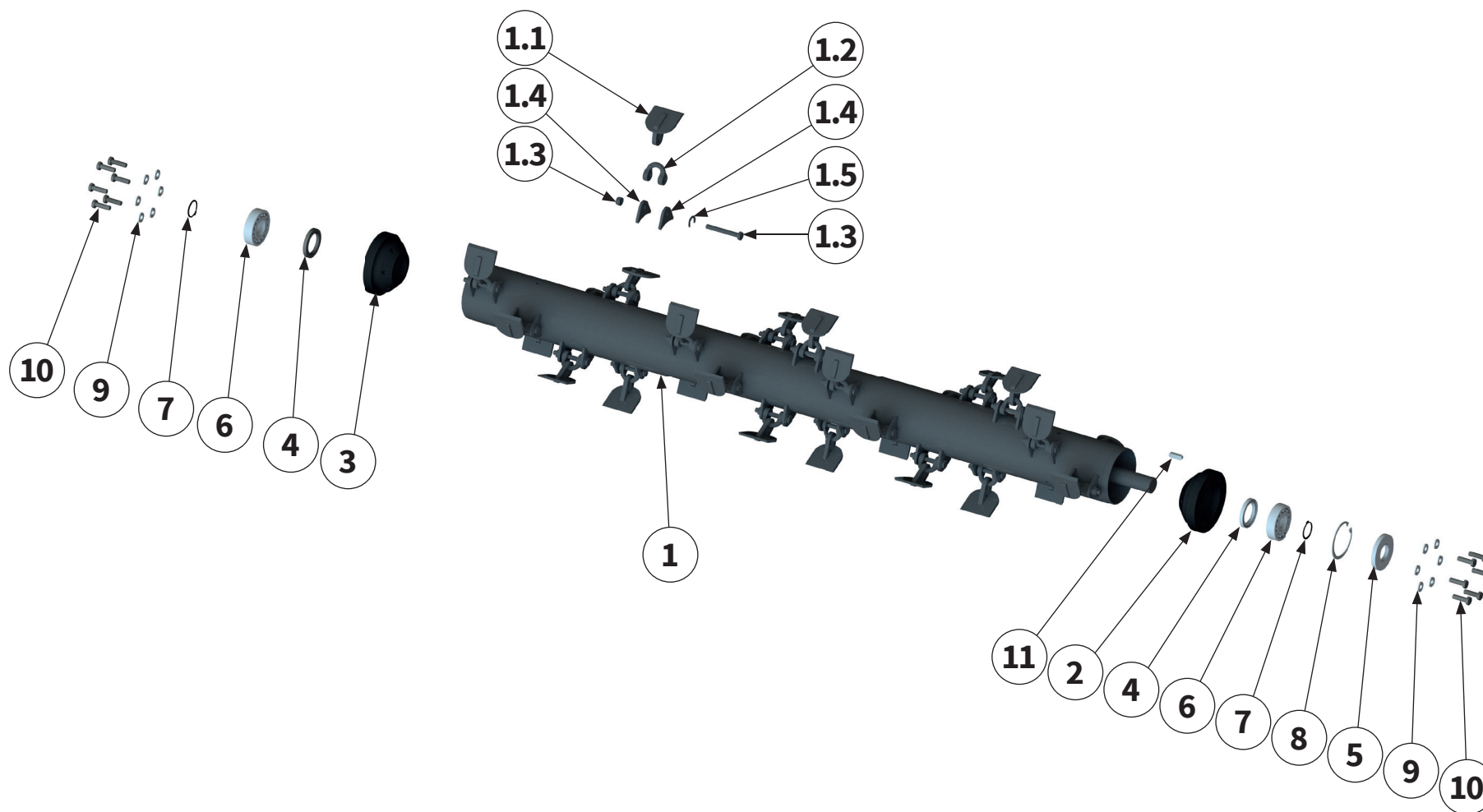

Pos.-Nr. No. Numéro Número	Ersatzteilnummer Manufacturer part number Numéro de pièce du fabricant Número de pieza del fabricante				DE Bezeichnung	EN Designation	FR Désignation	ES Designación
	Anzahl quantity quantité número							
	MU-E 140	MU-E 160	MU-E 180	MU-E 200				
9	MUNSKL10				Scheibe	washer	Disque	Arandela
	12	12	12	12				
10	MU980222				Schraube	bolt	Vis	Tornillo
	12	12	12	12				
11	MU0099955				Passfeder	parallel key	Clavette	Chaveta de ajuste
	1	1	1	1				

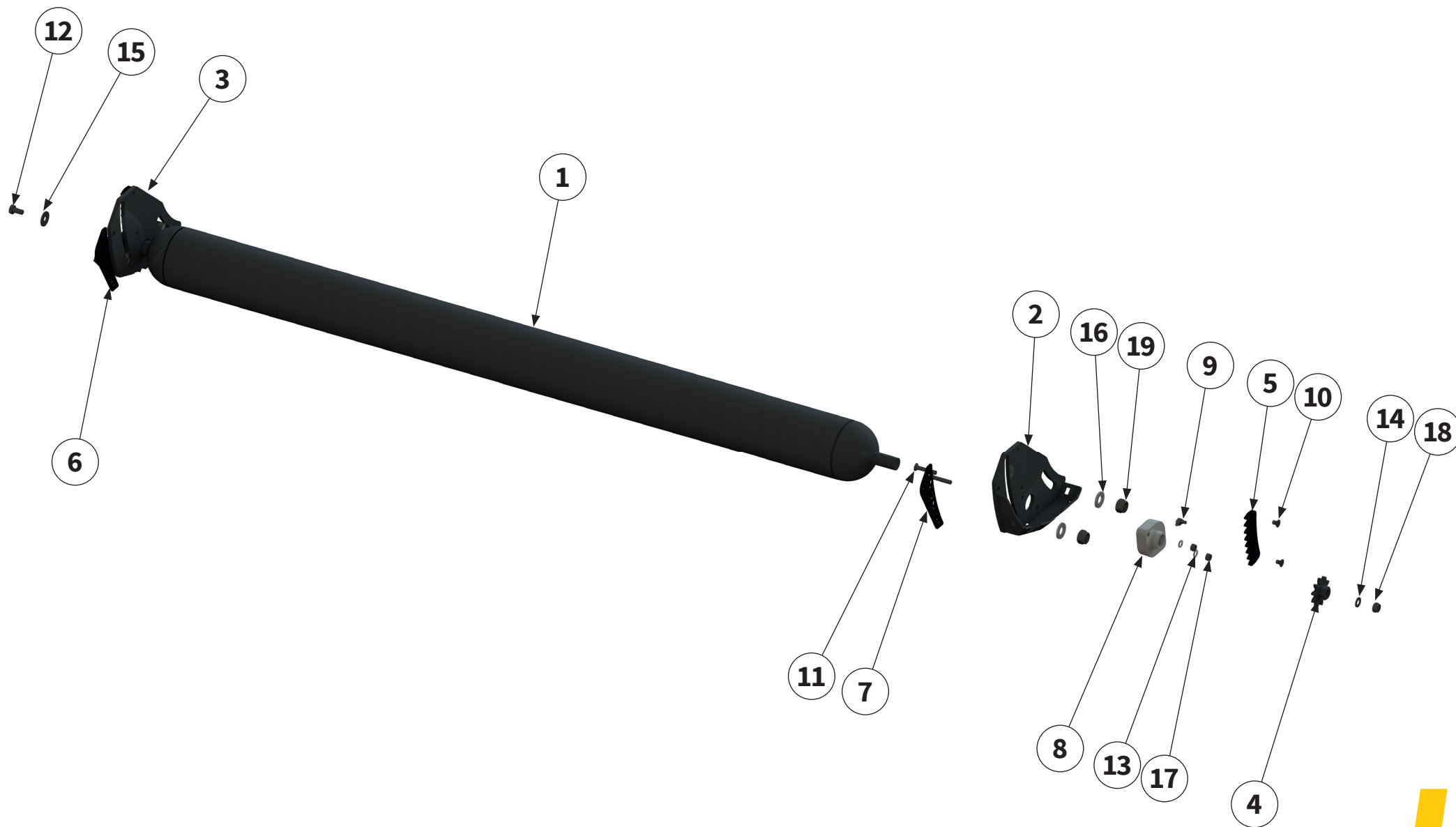

Pos.-Nr. No. Número	Ersatzteilnummer Manufacturer part number Numéro de pièce du fabricant Número de pieza del fabricante				DE Bezeichnung	EN Designation	FR Désignation	ES Designación
	Anzahl quantity quantité número							
	MU-E 140	MU-E 160	MU-E 180	MU-E 200				
1	MU0110793 1	MU0110794 1	MU0110795 1	MU0110796 1	Stützwalze	support roller	Rouleau d'appui	Cilindro de apoyo
2	00015272 1 1 1 1				Halteplatte	retainer plate	Plaque de support	Placa de retención
3	00015275 1 1 1 1				Halteplatte	retainer plate	Plaque de support	Placa de retención
4	00015277 2 2 2 2				Zahnrad	gearwheel	Roue dentée	Rueda dentada
5	00015278 2 2 2 2				Zahnstange	toothed rack	Crémaillère	Cremallera
6	00015261 1 1 1 1				Nonius	vernier scale	Nonio	Nonio
7	00015262 1 1 1 1				Nonius	vernier scale	Nonio	Nonio
8	00001673 2 2 2 2				Flanschlager mit Kappe	flange bearing with cap	Palier avec recouvrement	Cojinete con brida con cubierta
9	DIN71412C-H3-M08X1 2 2 2 2				Schmiernippel	lubricating nipple	Nipple de graissage	Engrasador
10	MU981902 4 4 4 4				Schraube	bolt	Vis	Tornillo
11	MU999004 4 4 4 4				Schraube	bolt	Vis	Tornillo
12	MU0099970 1 1 1 1				Schraube	bolt	Vis	Tornillo
13	MU0099999 4 4 4 4				Scheibe	washer	Disque	Arandela

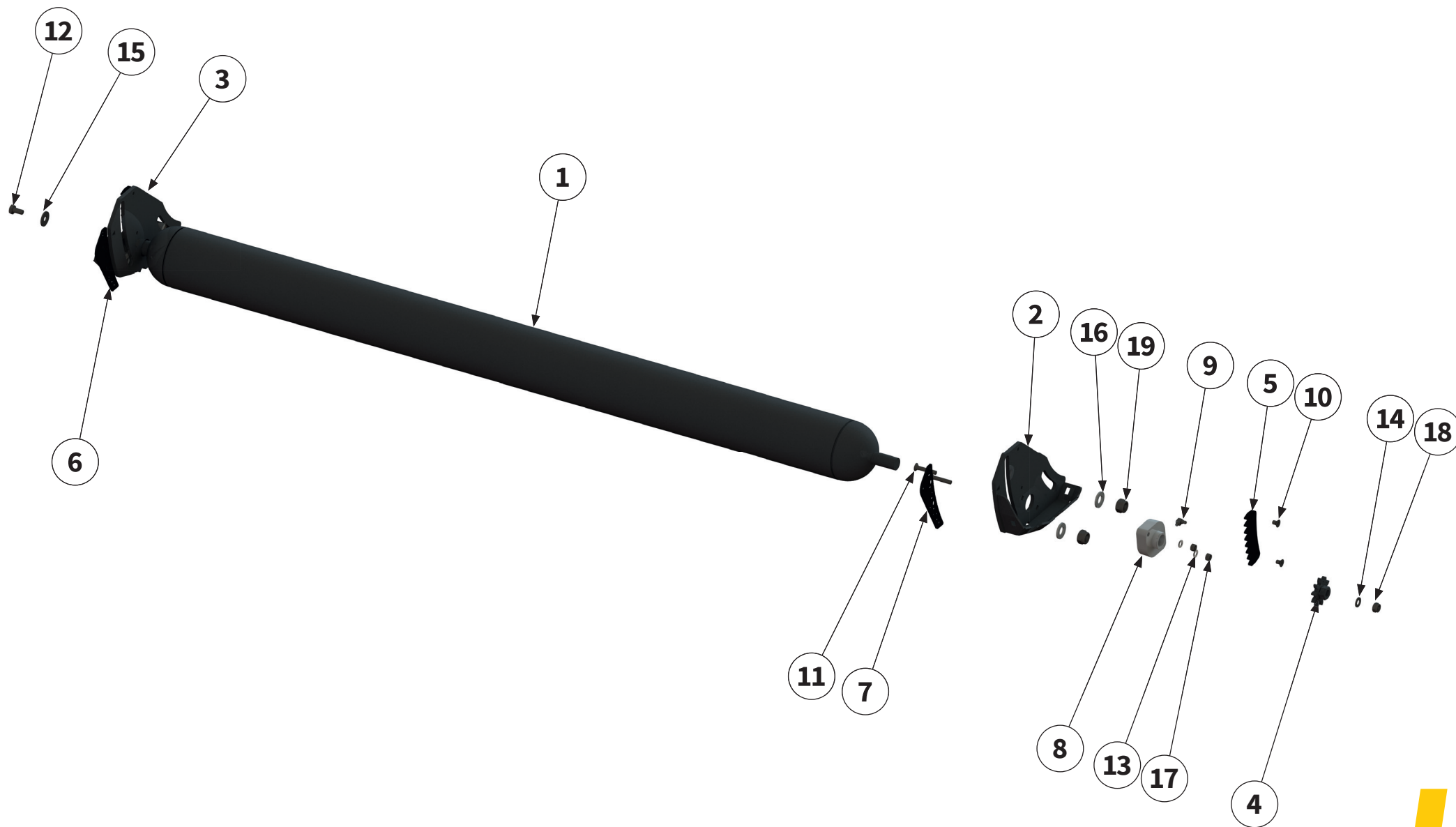

Pos.-Nr. No. Numéro Número	Ersatzteilnummer Manufacturer part number Numéro de pièce du fabricant Número de pieza del fabricante				DE Bezeichnung	EN Designation	FR Désignation	ES Designación
	Anzahl quantity quantité número							
	MU-E 140	MU-E 160	MU-E 180	MU-E 200				
14	MU980202				Scheibe	washer	Disque	Arandela
	2	2	2	2				
15	MU0099950				Scheibe	washer	Disque	Arandela
	1	1	1	1				
16	MUNSKL16				Scheibe	washer	Disque	Arandela
	2	2	2	2				
17	MU0099961				Scheibe	washer	Disque	Arandela
	4	4	4	4				
18	MU0099960				Mutter	nut	Écrou	Tuerca
	2	2	2	2				
19	MU980401				Mutter	nut	Écrou	Tuerca
	4	4	4	4				

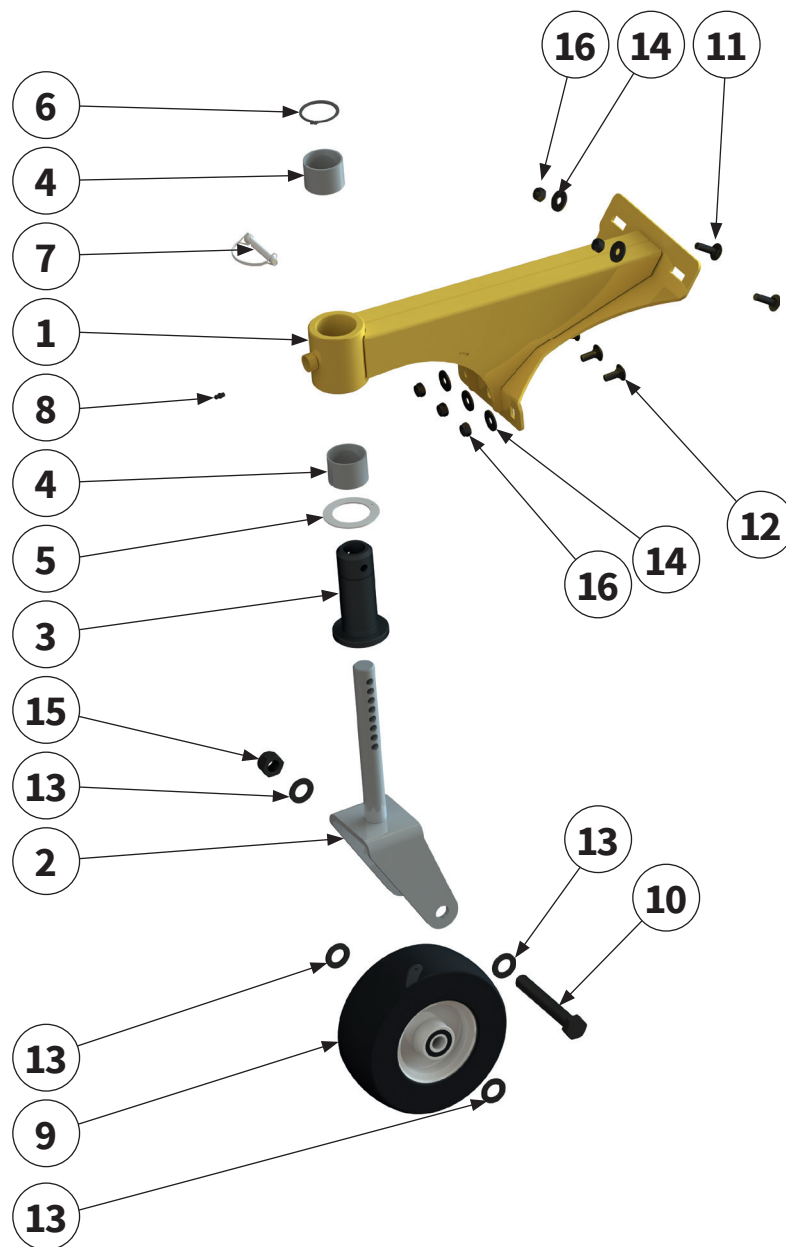

Pos.-Nr. No. Número	Ersatzteilnummer Manufacturer part number Numéro de pièce du fabricant Número de pieza del fabricante				DE Bezeichnung	EN Designation	FR Désignation	ES Designación
	Anzahl quantity quantité número							
	MU-E 140	MU-E 160	MU-E 180	MU-E 200				
1	00017204				Stützradträger	support wheel carrier	Support de la roue d'appui	Soporte de la rueda de soporte
	1	1	1	1				
2	MU0110751				Radgabel	wheel yoke	Fourche de roue	Horquilla de rueda
	1	1	1	1				
3	MU0211071				Flanschmuffe	bush	Douille	Casquillo
	1	1	1	1				
4	MU0211111				Gleitlagerbuchse	bush	Douille	Casquillo
	2	2	2	2				
5	MU0211101				Anlaufscheibe	thrust washer	Rondelle de butée	Arandela de tope
	1	1	1	1				
6	MU0099990				Sicherungsring	circlip	Bague de sécurité	Anillo de seguridad
	1	1	1	1				
7	MU0099946				Rohrklappsplint	pipe lynch pin	Goupille rabattable	Conector de tapa de tubo
	1	1	1	1				
8	DIN71412A-H1-M06X1				Schmiernippel	lubricating nipple	Nipple de graissage	Engrasador
	1	1	1	1				
9	MU0211091-3				Stützrad	support wheel	Roue d'appui	Rueda de soporte
	1	1	1	1				
10	MU0099977				Schraube	bolt	Vis	Tornillo
	1	1	1	1				
11	00000905				Schraube	bolt	Vis	Tornillo
	2	2	2	2				
12	00000903				Schraube	bolt	Vis	Tornillo
	3	3	3	3				
13	MU980505				Scheibe	washer	Disque	Arandela
	4	4	4	4				
14	MU0099950				Scheibe	washer	Disque	Arandela
	5	5	5	5				
15	MU0099959				Mutter	nut	Écrou	Tuerca
	1	1	1	1				
16	MU0099960				Mutter	nut	Écrou	Tuerca
	5	5	5	5				

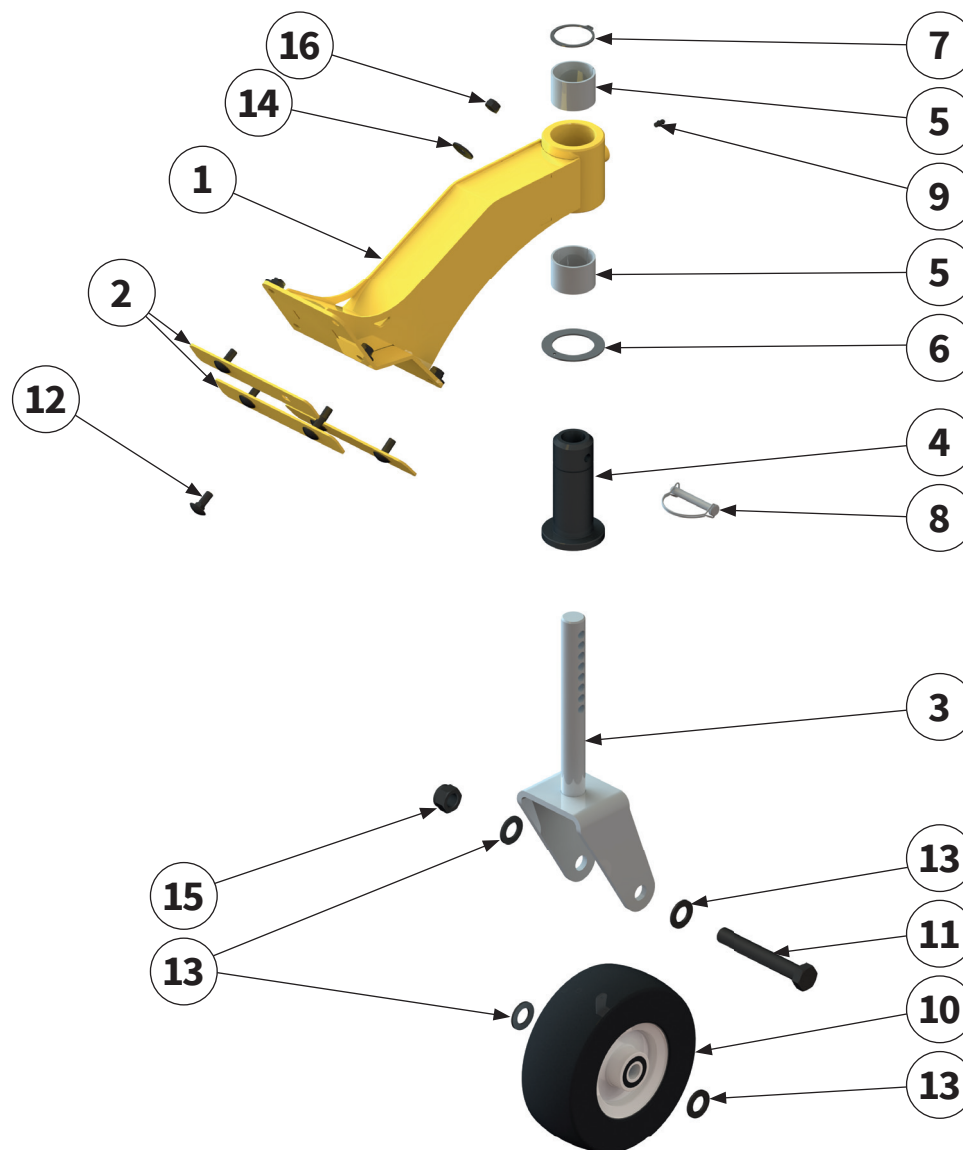

Pos.-Nr. No. Número	Ersatzteilnummer Manufacturer part number Numéro de pièce du fabricant Número de pieza del fabricante				DE Bezeichnung	EN Designation	FR Désignation	ES Designación
	Anzahl quantity quantité número							
	MU-E 140	MU-E 160	MU-E 180	MU-E 200				
1	00033188				Stützradträger	support wheel carrier	Support de la roue d'appui	Soporte de la rueda de soporte
	1	1	1	1				
2	00033190				Blech	sheet metal	Tôle	Chapa
	3	3	3	3				
3	MU0110751				Radgabel	wheel yoke	Fourche de roue	Horquilla de rueda
	1	1	1	1				
4	MU0211071				Flanschmuffe	bush	Douille	Casquillo
	1	1	1	1				
5	MU0211111				Gleitlagerbuchse	bush	Douille	Casquillo
	2	2	2	2				
6	MU0211101				Anlaufscheibe	thrust washer	Rondelle de butée	Arandela de tope
	1	1	1	1				
7	MU0099990				Sicherungsring	circlip	Bague de sécurite	Anillo de seguridad
	1	1	1	1				
8	MU0099946				Rohrklappsplint	pipe lynch pin	Goupille rabattable	Conector de tapa de tubo
	1	1	1	1				
9	DIN71412A-H1-M06X1				Schmiernippel	lubricating nipple	Nipple de graissage	Engrasador
	1	1	1	1				
10	MU0211091-3				Stützrad	support wheel	Roue d'appui	Rueda de soporte
	1	1	1	1				
11	MU0099977				Schraube	bolt	Vis	Tornillo
	1	1	1	1				
12	00000903				Schraube	bolt	Vis	Tornillo
	6	6	6	6				
13	MU980505				Scheibe	washer	Disque	Arandela
	4	4	4	4				
14	MU0099950				Scheibe	washer	Disque	Arandela
	6	6	6	6				
15	MU0099959				Mutter	nut	Écrou	Tuerca
	1	1	1	1				
16	MU0099960				Mutter	nut	Écrou	Tuerca
	6	6	6	6				

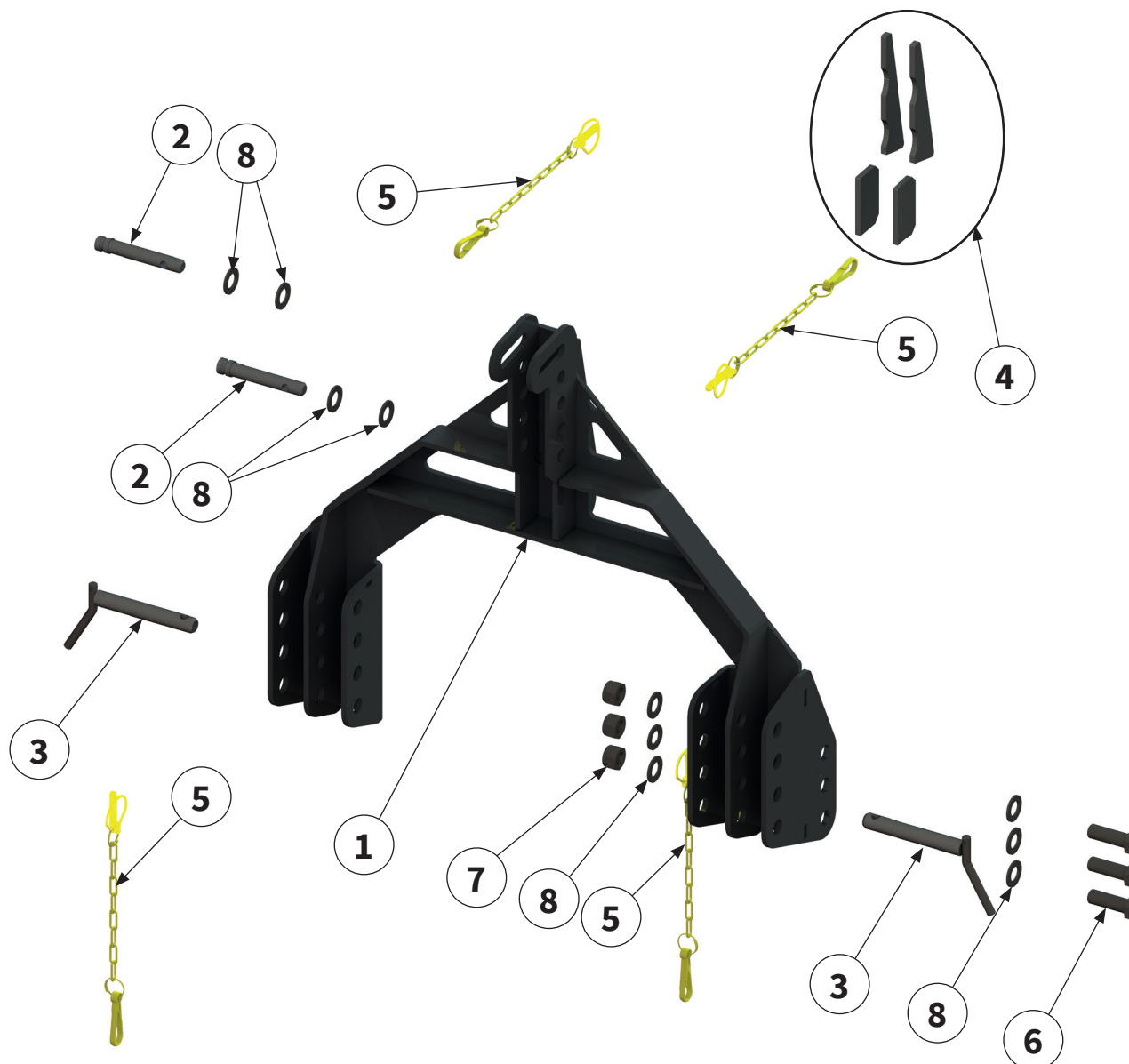

ANBAUDREIECK KAT.1 | Implement triangle Kat.1 |
Triangle d'attelage Kat.1 | Triángulo del dispositivo Kat.1

Pos.-Nr. No. Numéro Número	Ersatzteilnummer Manufacturer part number Numéro de pièce du fabricant Número de pieza del fabricante				DE Bezeichnung	EN Designation	FR Désignation	ES Designación
	Anzahl quantity quantité número							
	MU-E 140	MU-E 160	MU-E 180	MU-E 200				
1	00017335				Anbaudreieck	implement triangle	Triangle d'attelage	Triángulo del dispositivo
	1	1	1	1				
2	MU0010871				Unterlenkerbolzen	lower link pin	Boulon de maillon inférieur	Perno del brazo inferior
	2	2	2	2				
3	MAZ-81110				Oberlenkerbolzen	upper link pin	Boulon de liaison supérieure	Perno del brazo superior
	2	2	2	2				
4	00033003				Versteifungsstrebe	reinforcing strut	Tirant de renforcement	Tirante
	1	1	1	1				
5	MU2500106				Kette	chain	Chaîne	Cadena
	4	4	4	4				
6	MU981008				Schraube	bolt	Vis	Tornillo
	6	6	6	6				
7	MU0099959				Mutter	nut	Ècrou	Tuerca
	6	6	6	6				
8	MU980505				Scheibe	washer	Disque	Arandela
	16	16	16	16				

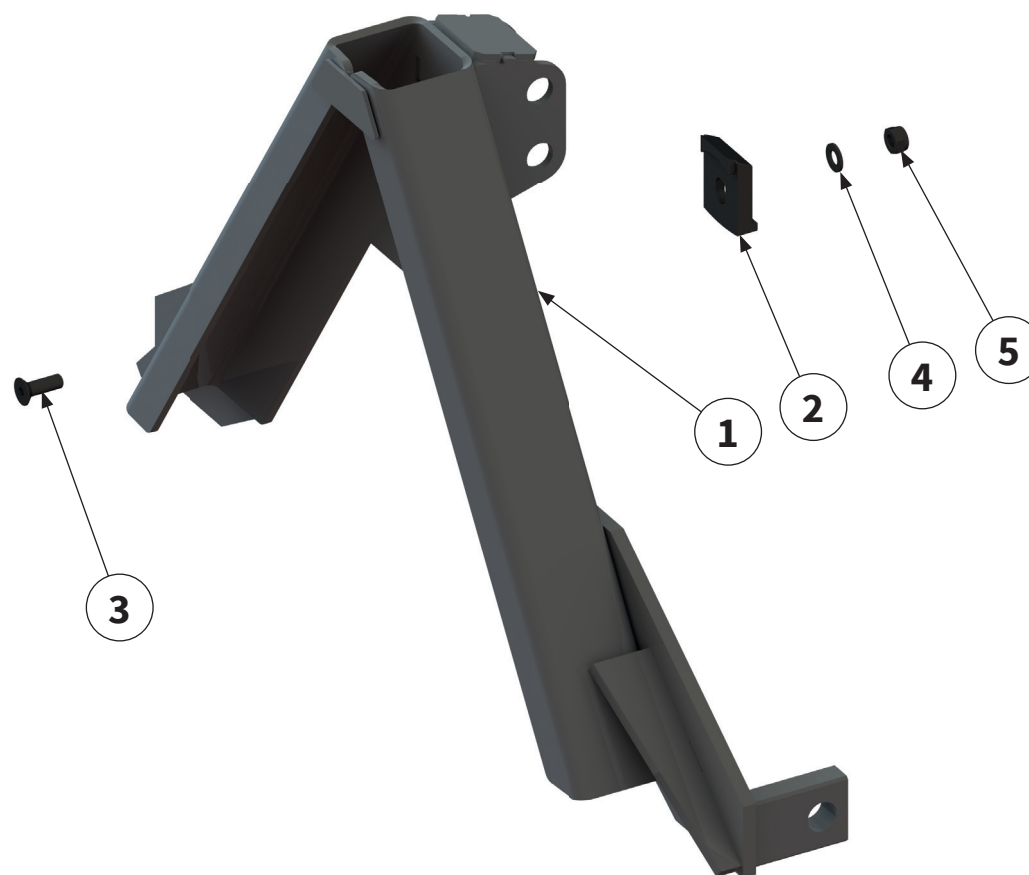

Pos.-Nr. No. Numéro Número	Ersatzteilnummer Manufacturer part number Numéro de pièce du fabricant Número de pieza del fabricante				DE Bezeichnung	EN Designation	FR Désignation	ES Designación
	Anzahl quantity quantité número							
	MU-E 140	MU-E 160	MU-E 180	MU-E 200				
1	00017133				Gerätedreieck	implement triangle	Triangle d'attelage	Triángulo del dispositivo
	1	1	1	1				
2	MU0011071				Sperrplatte	locking plate	Plaque de verrouillage	Placa de bloqueo
	1	1	1	1				
3	MU980339				Schraube	bolt	Vis	Tornillo
	1	1	1	1				
4	MU980302				Scheibe	washer	Disque	Arandela
	1	1	1	1				
5	MU980301				Mutter	nut	Écrou	Tuerca
	1	1	1	1				

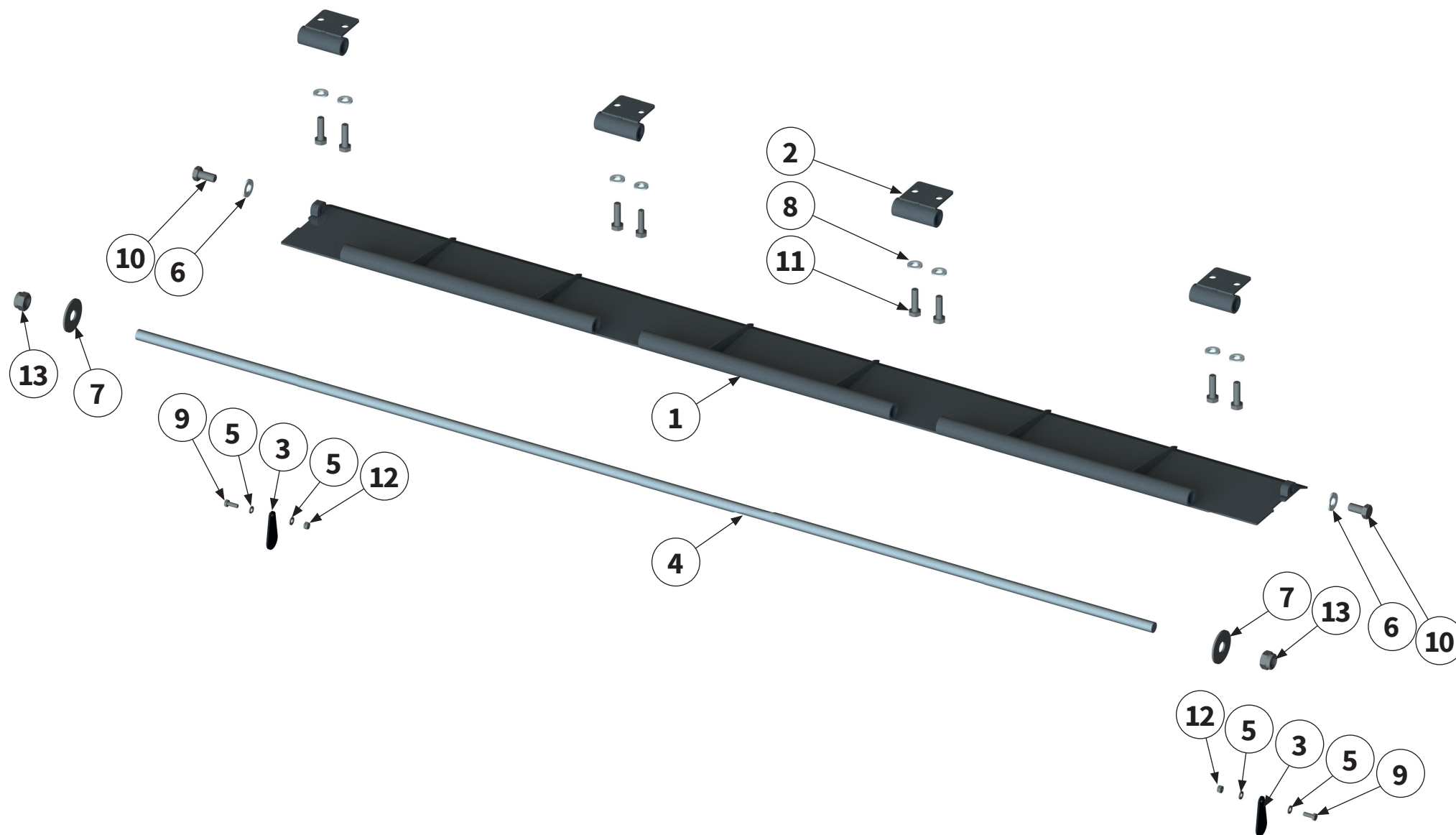

Pos.-Nr. No. Numéro Número	Ersatzteilnummer Manufacturer part number Numéro de pièce du fabricant Número de pieza del fabricante				DE Bezeichnung	EN Designation	FR Désignation	ES Designación
	Anzahl quantity quantité número							
	MU-E 140	MU-E 160	MU-E 180	MU-E 200				
1	00017387 1	00017179 1	00017352 1	00015298 1	Kurzschnittklappe	short-cut flap	Clapet de coupe courte	Tapa de corte corto
2	00015304 2 4 4 4				Halter	holder	Support	Soporte
3	00017538 2 2 2 2				Sicherheits- abdeckung	cover	Recouvrement	Cubierta
4	00017543 1	00017542 1	00017540 1	00017539 1	Achse	axle	Essieu	Eje
5	MU980011 4 4 4 4				Scheibe	washer	Disque	Arandela
6	MUNSKL12 2 2 2 2				Scheibe	washer	Disque	Arandela
7	MU980403 2 2 2 2				Scheibe	washer	Disque	Arandela
8	MUNSKL10 4 8 8 8				Scheibe	washer	Disque	Arandela
9	MU980004 2 2 2 2				Schraube	bolt	Vis	Tornillo
10	MU980341 2 2 2 2				Schraube	bolt	Vis	Tornillo
11	MU980222 4 8 8 8				Schraube	bolt	Vis	Tornillo
12	MU980010 2 2 2 2				Mutter	nut	Écrou	Tuerca
13	MU980401 2 2 2 2				Mutter	nut	Écrou	Tuerca



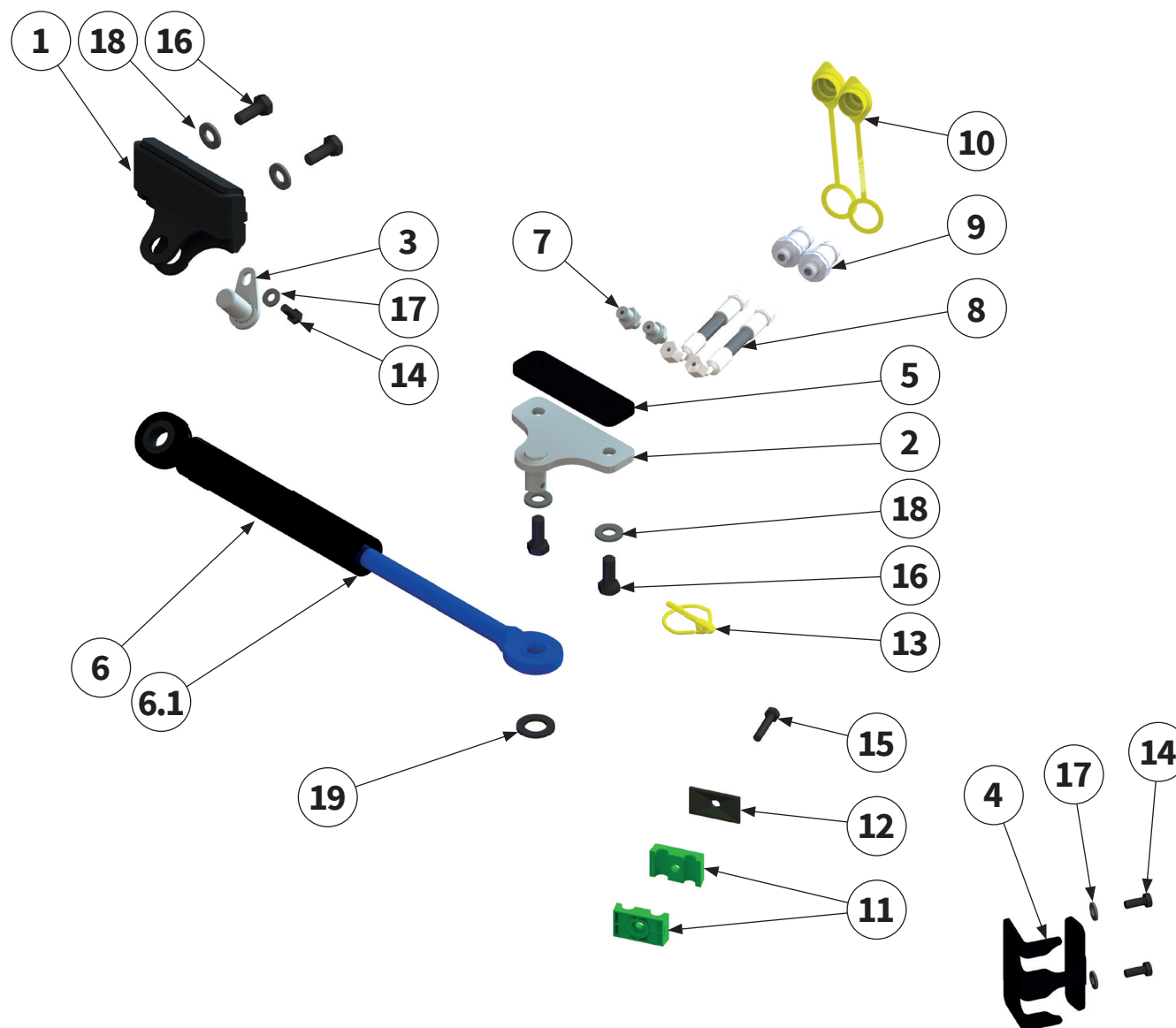

Pos.-Nr. No. Numéro Número	Ersatzteilnummer Manufacturer part number Numéro de pièce du fabricant Número de pieza del fabricante				DE Bezeichnung	EN Designation	FR Désignation	ES Designación
	Anzahl quantity quantité número							
	MU-E 140	MU-E 160	MU-E 180	MU-E 200				
1	00017196				Zylinderhalter	cylinder bracket	Porte-cylindre	Porta cilindro
	1	1	1	1				
2	00017193				Zylinderhalter	cylinder bracket	Porte-cylindre	Porta cilindro
	1	1	1	1				
3	00017190				Bolzen	pin	Axe	Perno
	1	1	1	1				
4	00017527				Halter	holder	Support	Soporte
	1	1	1	1				
5	00018310				Blech	sheet metal	Tôle	Chapa
	1	1	1	1				
6	00017187				Hydraulikzylinder	hydraulic cylinder	Vérin hydraulique	Cilindro hidráulico
	1	1	1	1				
6.1	MUDZ0002				Dichtsatz	packet seal	Kit d'étanchéité	Juego de estanqueización
	1	1	1	1				
7	00008101				Verschraubung	threaded connection	Raccord à vis	Unión atornillada
	2	2	2	2				
8	00014432				Hydraulikschlauch	hydraulic hose	Tuyau hydraulique	Tubo flexible hidráulico
	2	2	2	2				
9	MHS-060807				Hydraulikstecker	hydraulic connector	Raccord hydraulique	Conector hidráulico
	2	2	2	2				
10	MKF-3127				Staubschutzkappe	dust cap	Couvercle anti-pousière	Caperuza guardapolvo
	2	2	2	2				
11	00017532				Schellenkörper	clamp body	Corps de collier	Cuerpo de la abrazadera
	1	1	1	1				
12	00002475				Deckplatte	cover plate	Plaque de recouvrement	Placa de revestimiento
	1	1	1	1				
13	00005052				Klappstecker	lynch pin	Esse d'essieu	Pasador abatible
	1	1	1	1				

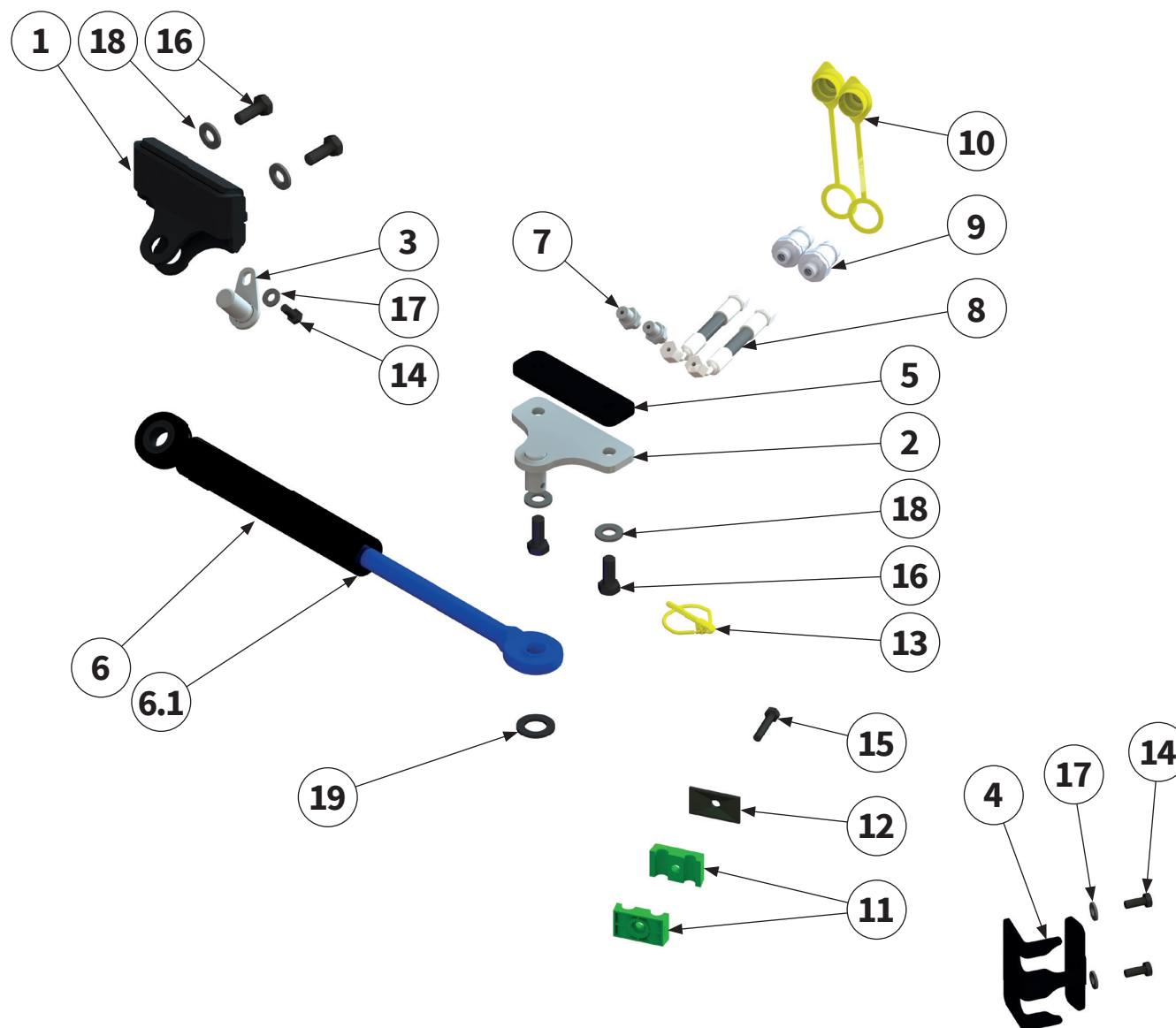

Pos.-Nr. No. Número	Ersatzteilnummer Manufacturer part number Numéro de pièce du fabricant Número de pieza del fabricante				DE Bezeichnung	EN Designation	FR Désignation	ES Designación
	Anzahl quantity quantité número							
	MU-E 140	MU-E 160	MU-E 180	MU-E 200				
14	MU980115				Schraube	bolt	Vis	Tornillo
	3	3	3	3				
15	MU980112				Schraube	bolt	Vis	Tornillo
	1	1	1	1				
16	MU980307				Schraube	bolt	Vis	Tornillo
	2	2	2	2				
17	MUNSKL08				Scheibe	washer	Disque	Arandela
	3	3	3	3				
18	MUNSKL12				Scheibe	washer	Disque	Arandela
	4	4	4	4				
19	MU980505				Scheibe	washer	Disque	Arandela
	1	1	1	1				



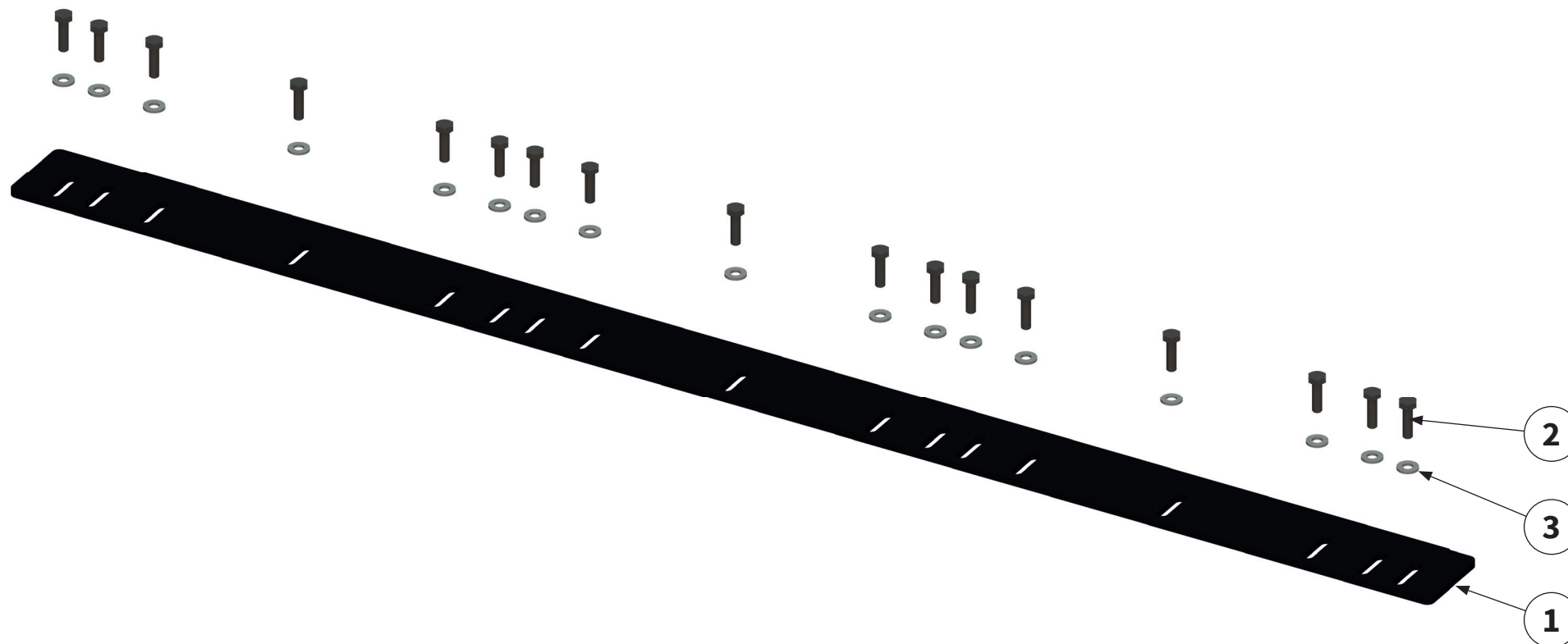

Pos.-Nr. No. Numéro Número	Ersatzteilnummer Manufacturer part number Numéro de pièce du fabricant Número de pieza del fabricante				DE Bezeichnung	EN Designation	FR Désignation	ES Designación
	Anzahl quantity quantité número							
	MU-E 140	MU-E 160	MU-E 180	MU-E 200				
1	00017389 1	00017364 1	00017356 1	00017325 1	Schneidblech	cutting bar	Contre-lame réglable	Carril de corte
2	MU980222				Schraube	bolt	Vis	Tornillo
	13	17	19	21				
3	MUNSKL10				Scheibe	washer	Disque	Arandela
	13	17	19	21				

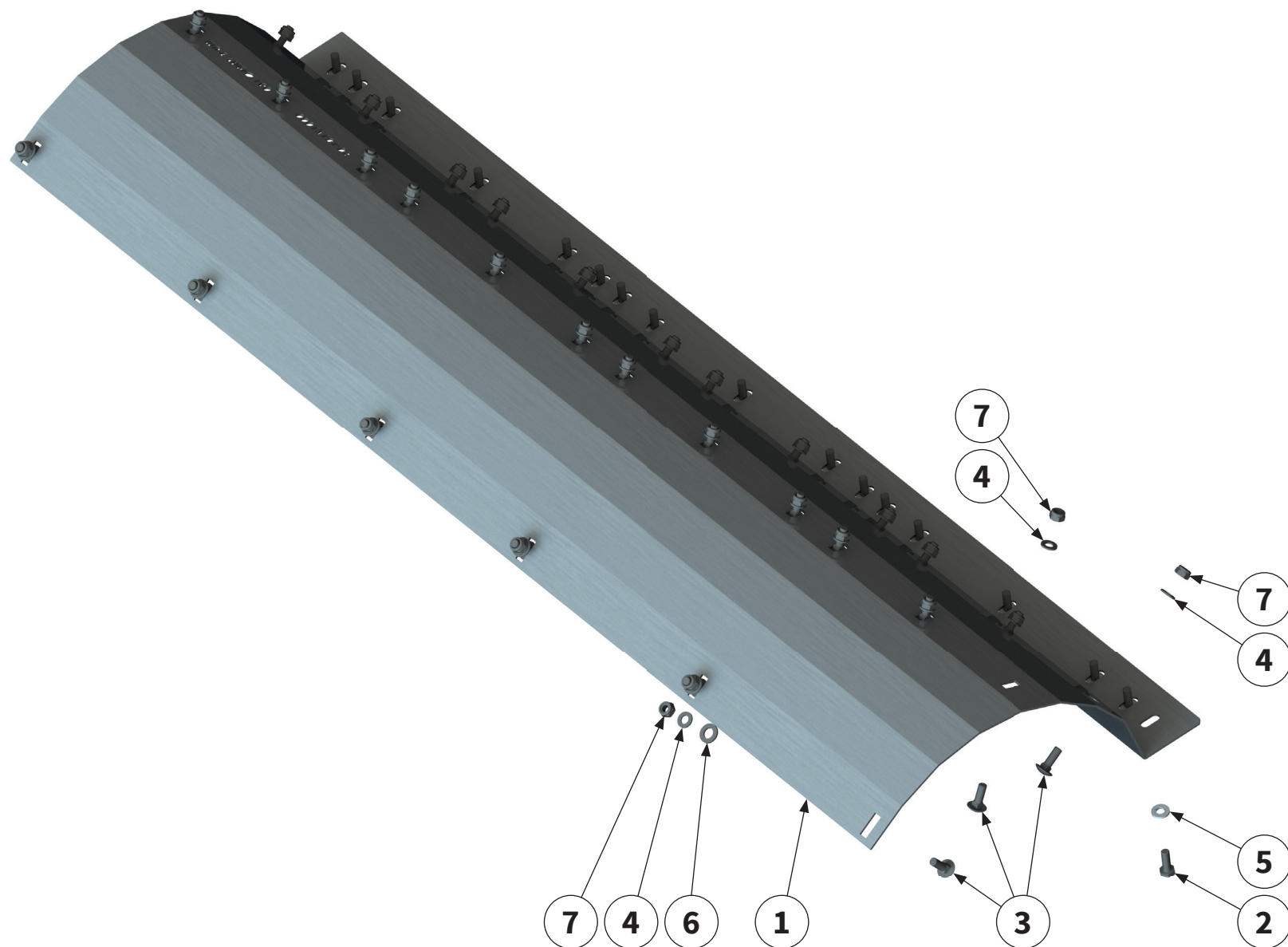

Pos.-Nr. No. Numéro Número	Ersatzteilnummer Manufacturer part number Numéro de pièce du fabricant Número de pieza del fabricante				DE Bezeichnung	EN Designation	FR Désignation	ES Designación
	Anzahl quantity quantité número							
	MU-E 140	MU-E 160	MU-E 180	MU-E 200				
1	00017391 1	00017181 1	00017357 1	00015312 1	Verschleißeinlage	wear insert	Intercalaire anti-usure	Junta de desgaste
2	MU980205				Schraube	bolt	Vis	Tornillo
	13	17	19	21				
3	00000904				Schraube	bolt	Vis	Tornillo
	27	31	38	38				
4	MU980202				Scheibe	washer	Disque	Arandela
	27	31	38	38				
5	MUNSKL10				Scheibe	washer	Disque	Arandela
	13	17	19	21				
6	MU980302				Scheibe	washer	Disque	Arandela
	6	6	8	8				
7	MU0099960				Mutter	nut	Écrou	Tuerca
	27	31	38	38				

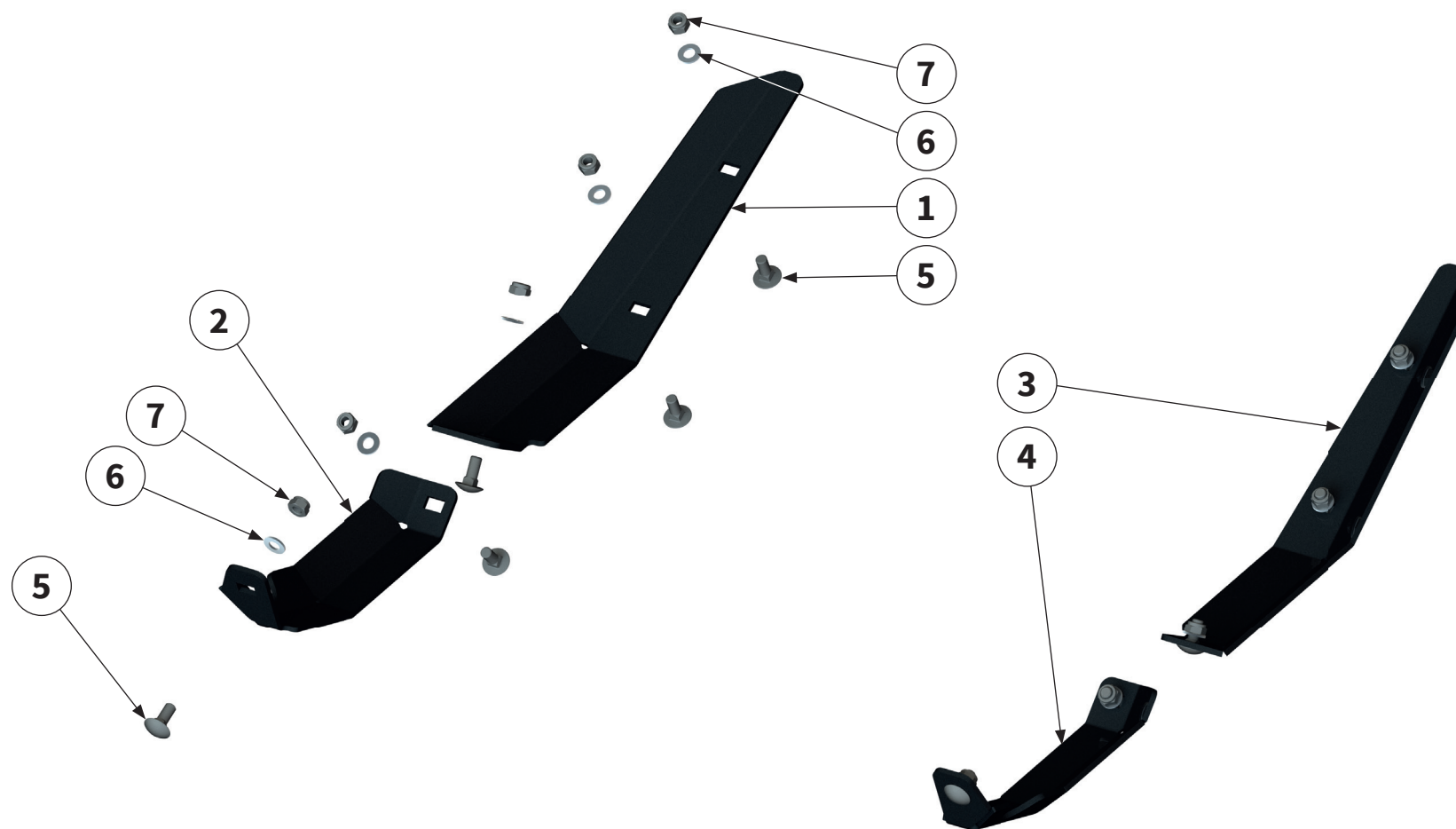

Fahrtrichtung links
Direction of travel left
Dans le sens de la marche á gauche
En sentido de marcha a la izquierda

Fahrtrichtung rechts
Direction of travel right
Dans le sens de la marche á droite
En sentido de la marcha a la derecha

Pos.-Nr. No. Numéro Número	Ersatzteilnummer Manufacturer part number Numéro de pièce du fabricant Número de pieza del fabricante				DE Bezeichnung	EN Designation	FR Désignation	ES Designación
	Anzahl quantity quantité número							
	MU-E 140	MU-E 160	MU-E 180	MU-E 200				
1	00015313				Verschleißkufe	wear runner	Patin d'usure	Cuchilla de desgaste
	1	1	1	1				
2	00015315				Verschleißkufe	wear runner	Patin d'usure	Cuchilla de desgaste
	1	1	1	1				
3	00015314				Verschleißkufe	wear runner	Patin d'usure	Cuchilla de desgaste
	1	1	1	1				
4	00015316				Verschleißkufe	wear runner	Patin d'usure	Cuchilla de desgaste
	1	1	1	1				
5	MU980107				Schraube	bolt	Vis	Tornillo
	10	10	10	10				
6	MU0099999				Scheibe	washer	Disque	Arandela
	10	10	10	10				
7	MU0099961				Mutter	nut	Écrou	Tuerca
	10	10	10	10				

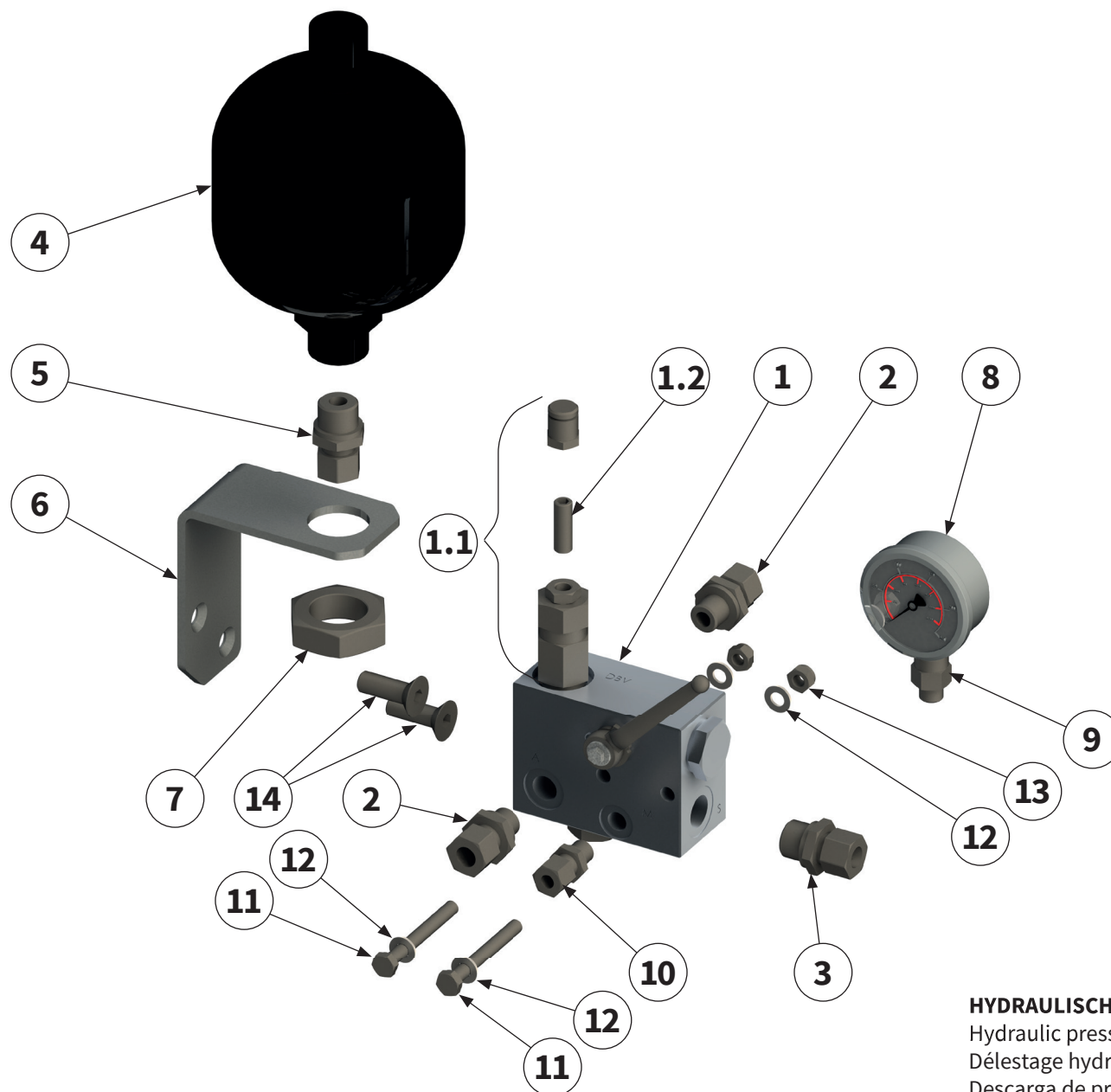

HYDRAULISCHE DRUCKENTLASTUNG MU-SOFA |
 Hydraulic pressure relief MU-SOFA |
 Délestage hydraulique MU-SOFA |
 Descarga de presión hidráulica MU-SOFA |

Pos.-Nr. No. Número	Ersatzteilnummer Manufacturer part number Numéro de pièce du fabricant Número de pieza del fabricante				DE Bezeichnung	EN Designation	FR Désignation	ES Designación
	Anzahl quantity quantité número							
	MU-E 140	MU-E 160	MU-E 180	MU-E 200				
1	1552600				Ventilblock	Valve block	Bloc de soupapes	Bloque de válvulas
	1	1	1	1				
1.1	180352				Ventileinsatz	Valve core	Garniture de s oupape	Inserto de válvula
	1	2	1	1				
1.2	209343				Gewindestift	threaded pin	Tige filetée	Perno roscado
	1	1	1	1				
2	GE-12-PLR-3/8				Verschraubung	Screwed connection	Raccord à vis	Atornillamiento
	2	2	2	2				
3	GE-12-PLR-1/2				Verschraubung	Screwed connection	Raccord à vis	Atornillamiento
	1	1	1	1				
4	209162				Stickstoffspeicher	Nitrogen accumulator	Poche d'azote	Burbuja de nitrógeno
	1	1	1	1				
5	GE-12-PLM-22X1.5				Verschraubung	Screwed connection	Raccord à vis	Atornillamiento
	1	2	1	1				
6	00009033				Haltewinkel	holder	Support	Soporte
	1	1	1	1				
7	00001159				Mutter	nut	Écrou	Tuerca
	1	1	1	1				
8	112922				Manometer	Pressure gauge	Manomètre	Manómetro
	1	1	1	1				
9	MAV-LR08R1/4Zoll				Verschraubung	Screwed connection	Raccord à vis	Atornillamiento
	1	1	1	1				



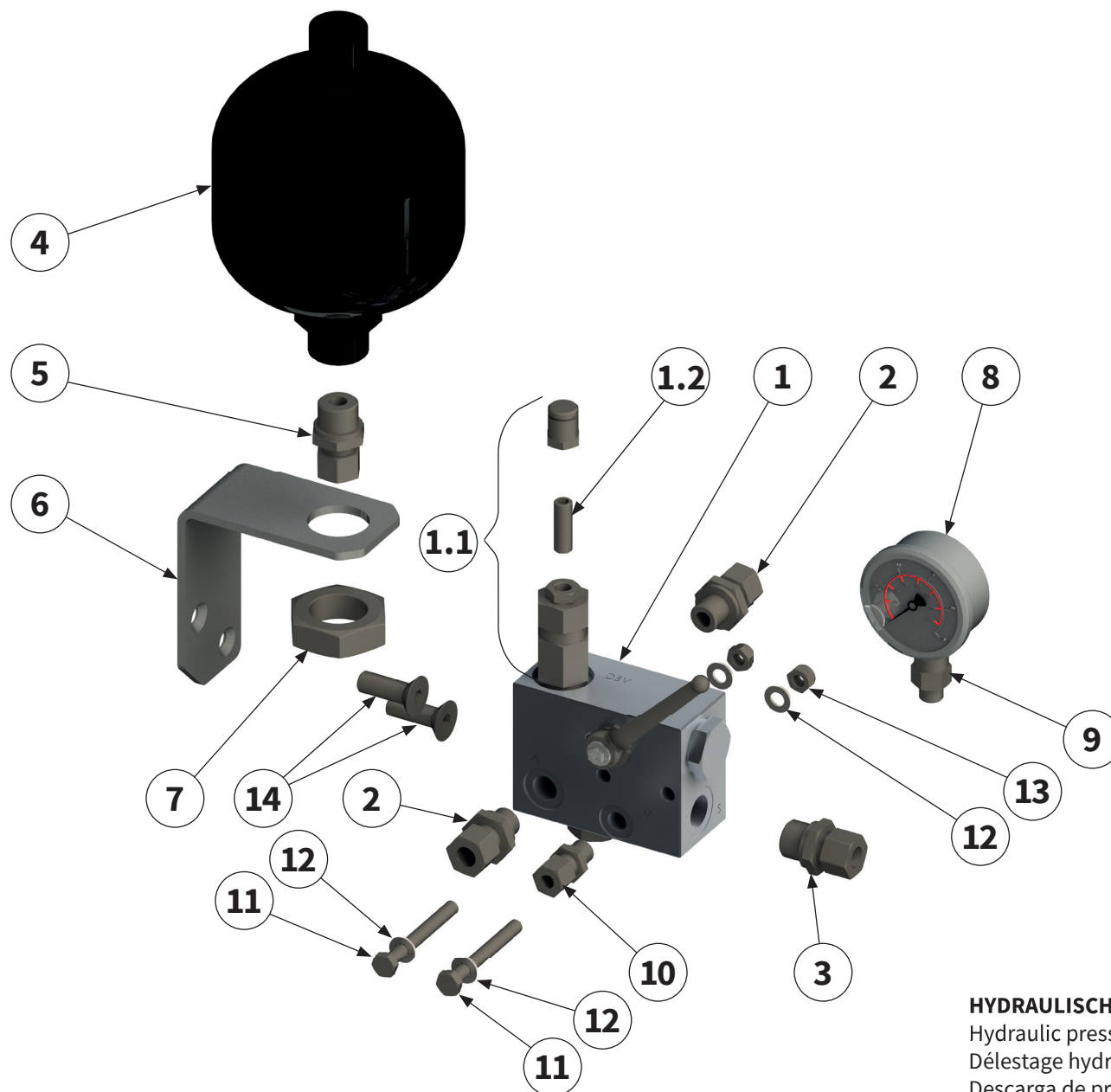

HYDRAULISCHE DRUCKENTLASTUNG MU-SOFA |
 Hydraulic pressure relief MU-SOFA |
 Délestage hydraulique MU-SOFA |
 Descarga de presión hidráulica MU-SOFA |

Pos.-Nr. No. Numéro Número	Ersatzteilnummer Manufacturer part number Numéro de pièce du fabricant Número de pieza del fabricante				DE Bezeichnung	EN Designation	FR Désignation	ES Designación
	Anzahl quantity quantité número							
	MU-E 140	MU-E 160	MU-E 180	MU-E 200				
10	GE-08-PLR-1/4				Verschraubung	Screwed connection	Raccord à vis	Atornillamiento
	1	1	1	1				
11	MU980122				Schraube	bolt	Vis	Tornillo
	2	2	2	2				
12	MU0099999				Scheibe	washer	Disque	Arandela
	6	6	6	6				
13	MU0099961				Mutter	nut	Écrou	Tuerca
	4	4	4	4				
14	MU980134				Schraube	bolt	Vis	Tornillo
	2	2	2	2				

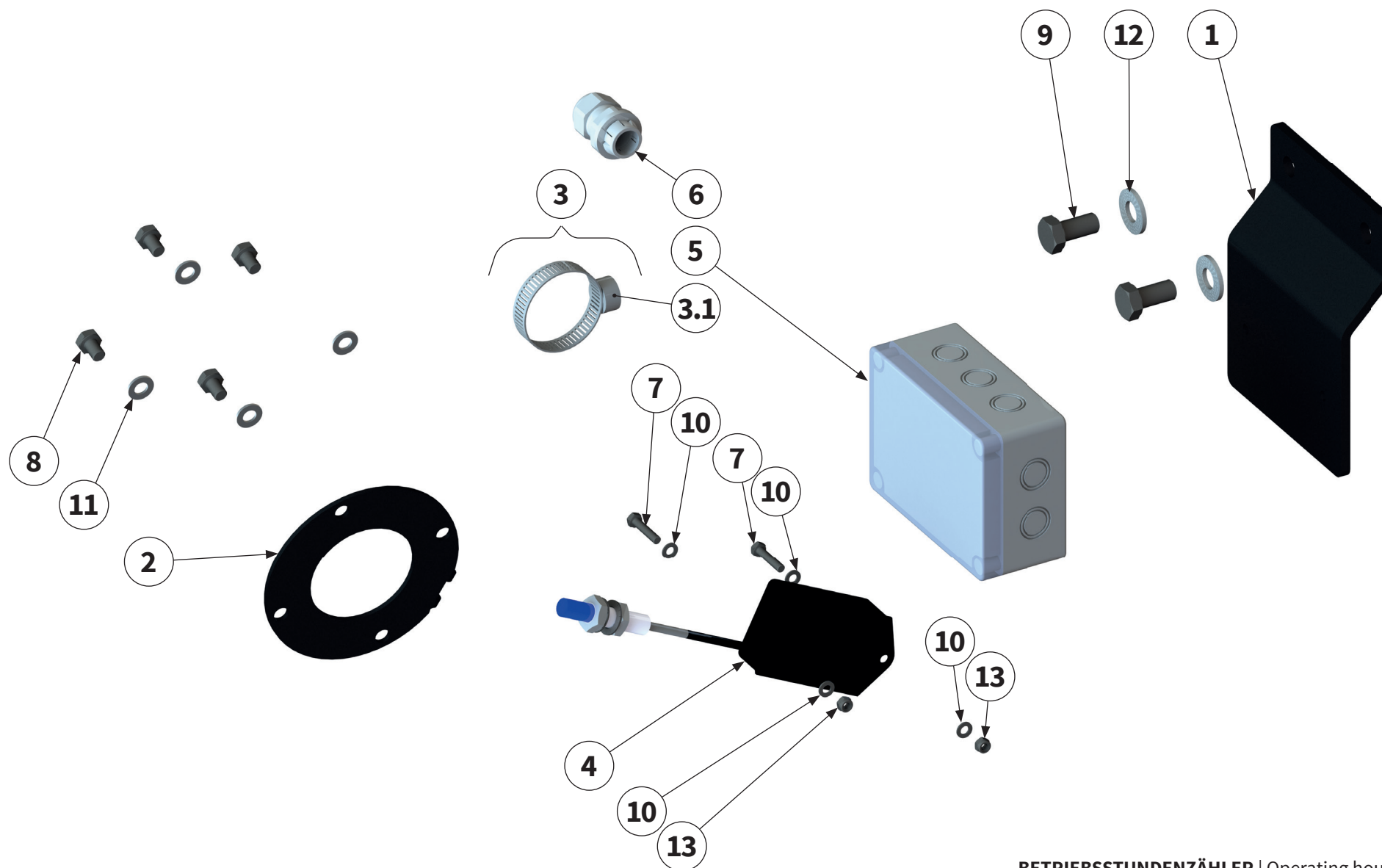

Pos.-Nr. No. Número	Ersatzteilnummer Manufacturer part number Numéro de pièce du fabricant Número de pieza del fabricante				DE Bezeichnung	EN Designation	FR Désignation	ES Designación
	Anzahl quantity quantité número							
	MU-E 140	MU-E 160	MU-E 180	MU-E 200				
1	00017546				Halter	holder	Support	Soporte
	1	1	1	1				
2	00017322				Blech	sheet metal	Tôle	Chapa
	1	1	1	1				
3	00017319				Drehzahlgeber- magnet mit Schelle	rpm sensor magnet with clamp	Régulateur de vitesse Aimant avec Collier	Imán del transmi- sor del número de revoluciones con Abrazadera
	1	1	1	1				
3.1	00008229				Drehzahlgeber- magnet	rpm sensor magnet	Régulateur de vitesse Aimant	Imán del transmisor del número de revo- luciones
	1	1	1	1				
4	00015048				Betriebsstunden- zähler	operating hours counter	Compteur horaire	Contador de horas de servicio
	1	1	1	1				
5	00010187				Verteilerkasten	distribution box	boîte de distribution	caja de distribución
	1	1	1	1				
6	00008094				Verschraubung	threaded connection	Raccord à vis	Unión atornillada
	1	1	1	1				
7	MU980008				Schraube	bolt	Vis	Tornillo
	2	2	2	2				
8	MU980159				Schraube	bolt	Vis	Tornillo
	4	4	4	4				
9	MU980341				Schraube	bolt	Vis	Tornillo
	2	2	2	2				
10	MU980006				Scheibe	washer	Disque	Arandela
	4	4	4	4				
11	MU0099999				Scheibe	washer	Disque	Arandela
	4	4	4	4				
12	MUNSKL12				Scheibe	washer	Disque	Arandela
	2	2	2	2				
13	MU980009				Mutter	nut	Écrou	Tuerca
	2	2	2	2				

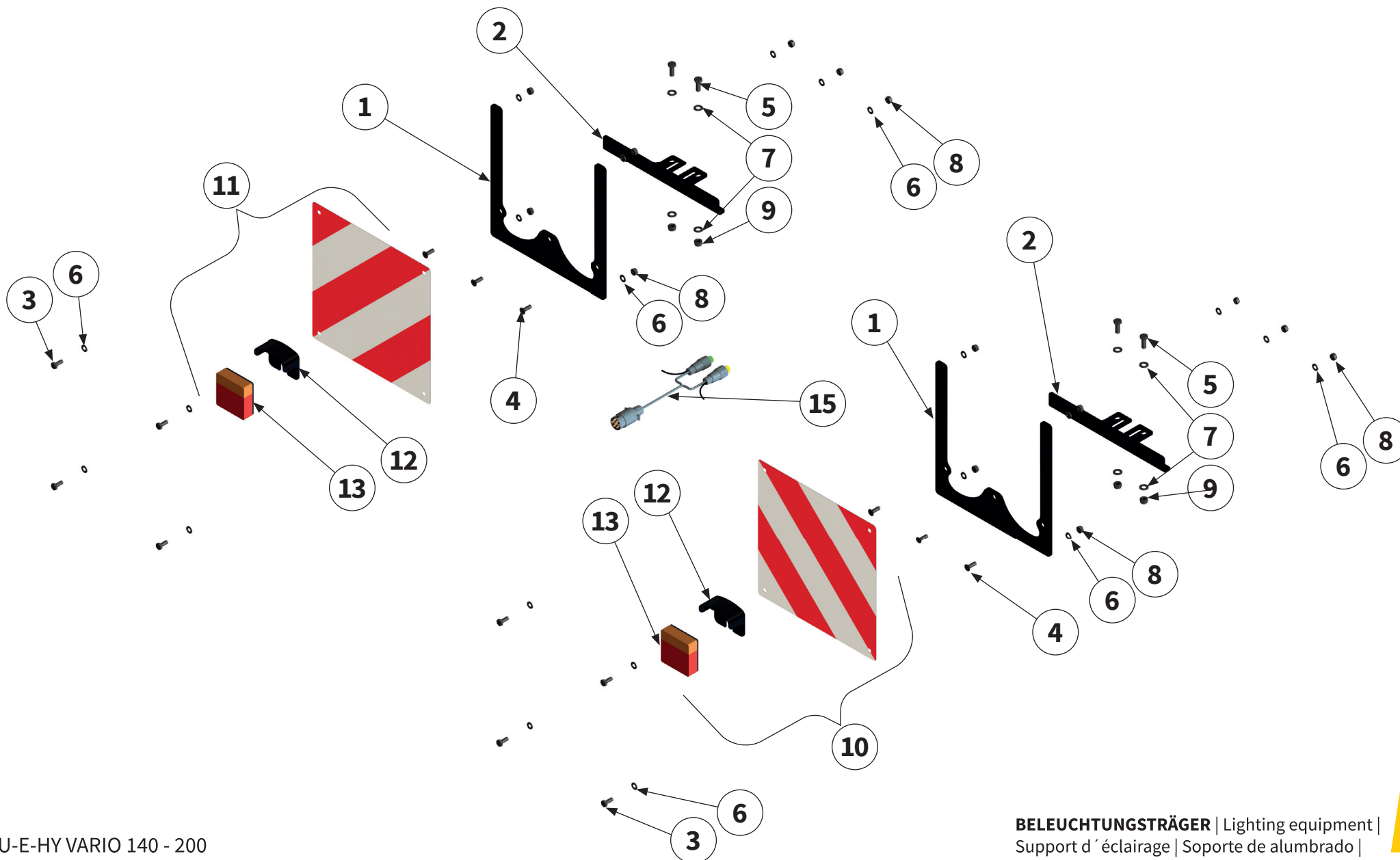

Pos.-Nr. No. Número	Ersatzteilnummer Manufacturer part number Numéro de pièce du fabricant Número de pieza del fabricante					DE Bezeichnung	EN Designation	FR Désignation	ES Designación
	Anzahl quantity quantité número								
	MU-E 120	MU-E 140	MU-E 160	MU-E 180	MU-E 200				
1	2	2	00014968 2	2	2	Warntafelhalter	warning sign holder	Support de panneau de signalisation	Soporte del panel de aviso
2	2	2	00017317 2	2	2	Beleuchtungs- halter	holder	Support	Soporte
3	8	8	MU980208 8	8	8	Schraube	bolt	Vis	Tornillo
4	6	6	MU980252 6	6	6	Schraube	bolt	Vis	Tornillo
5	4	4	MU980307 4	4	4	Schraube	bolt	Vis	Tornillo
6	22	22	MU980202 22	22	22	Scheibe	washer	Disque	Arandela
7	8	8	MU980302 8	8	8	Scheibe	washer	Disque	Arandela
8	14	14	MU0099960 14	14	14	Mutter	nut	Écrou	Tuerca
9	4	4	MU980301 4	4	4	Mutter	nut	Écrou	Tuerca
10	1	1	3H4157-101 1	1	1	Warntafel mit LED Beleuchtungsein- richtung	warning sign with LED lighting equipment	Panneau de signal- isation avec LED système d'éclairage	Panel de aviso con LED dispositivo de iluminación
11	1	1	3H4156-101 1	1	1	Warntafel mit LED Beleuchtungsein- richtung	warning sign with LED lighting equipment	Panneau de signal- isation avec LED système d'éclairage	Panel de aviso con LED dispositivo de iluminación
12	2	2	308026-0230 2	2	2	Schutzabdeckung	protective cover	Recouvrement de protection	Cubierta protectora
13	2	2	3H3158-090 2	2	2	LED Blinkerleuchte	LED Direction indicator	LED luminaire fclignotant	LED lámpara intermitente
14	2	2	R1130/B 2	2	2	Warntafel	warning sign	Panneau de signalisation	Panel de aviso
15	1	1	00034366 1	1	1	Kabelbaum	wiring harness	Faisceau de câblage	Arnés de cableado

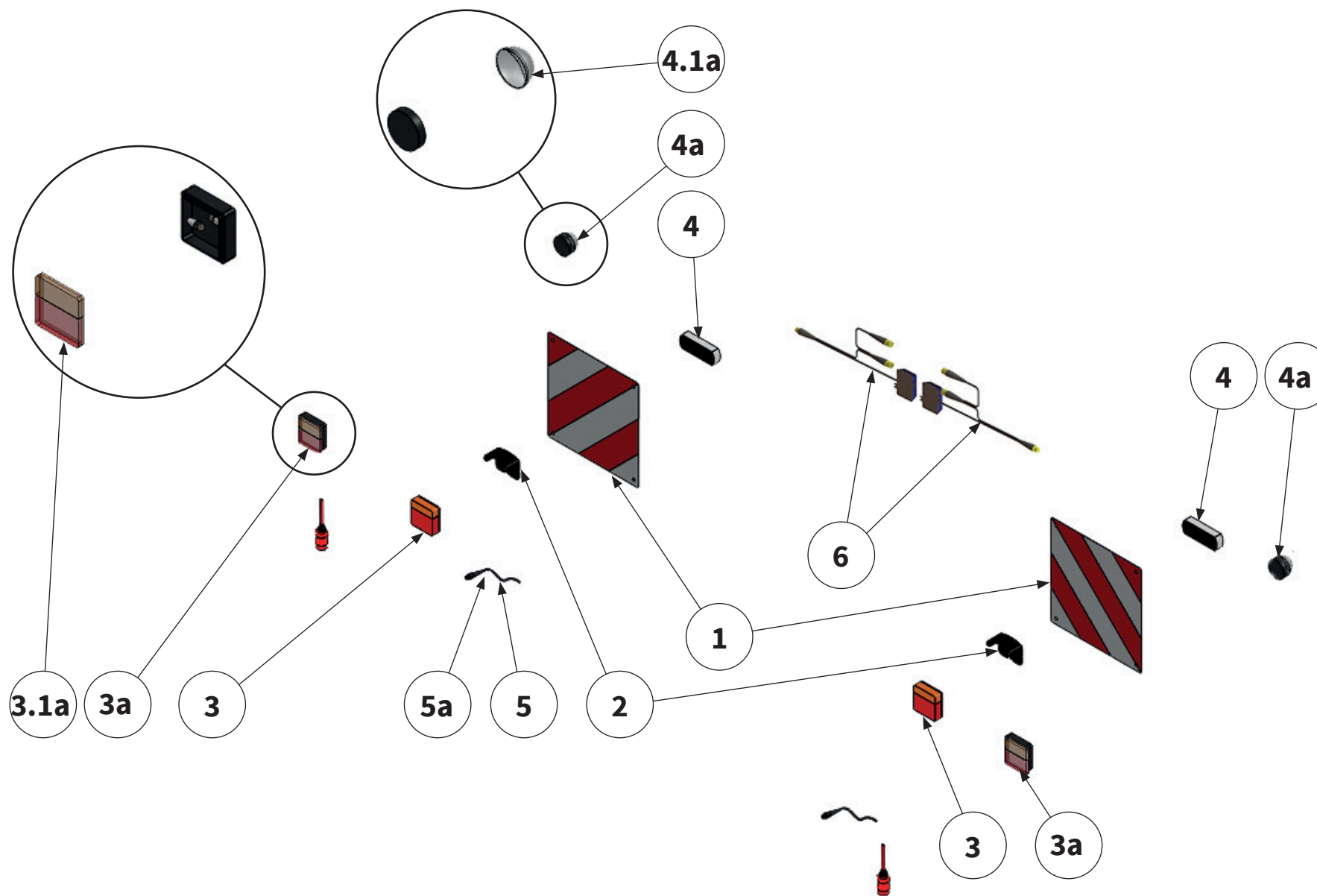

Pos.-Nr. No. Número	Ersatzteilnummer Manufacturer part number Numéro de pièce du fabricant Número de pieza del fabricante				DE Bezeichnung	EN Designation	FR Désignation	ES Designación
	Anzahl quantity quantité número							
	MU-E 140	MU-E 160	MU-E 180	MU-E 200				
1	R 1130/B				Warntafel	warning sign	Panneau de signalisation	Panel de aviso
	2	2	2	2				
2	308026-0230				Schutzabdeckung	protection cover	Recouvrement de protection	Cubierta protectora
	2	2	2	2				
3	3H3148-001				LED Blinkerleuchte	LED Direction indicator	LED luminaire fclignotant	LED lámpara intermitente
	2	2	2	2				
3a	319016-0020				Leuchte kpl.	light cpl.	Luminaire	Lámpara
	2	2	2	2				
3.1a	3L3348-002				Deckel	cap	Couvercle	Tapa
	2	2	2	2				
4	2P3158-011				LED Positionsleuchte	LED position light	LED position clignotant	LED Pilotos delan- teros de posición
	2	2	2	2				
4a	319016-0021				Leuchte kpl.	light cpl.	Luminaire	Lámpara
	2	2	2	2				
4.1a	2L3348-001				Deckel	cap	Couvercle	Tapa
	2	2	2	2				
5	130400-016 (5m)				LED Verbindungskabel	LED connecting cable	LED câble de connexion	LED cable de conexión
	2	2	2	2				
5a	130400-014 (7m)							
	2	2	2	2				
6	180500-021				LED-Blinkerüber- wachung	turn signal monitor- ing	Surveillance des clignotants	Señal de giro de monitoreo
	2	2	2	2				



Bei weiteren Fragen zu Technik und Einsatz Ihres
Gerätes stehen Ihnen unsere Mitarbeiter oder unsere
Vertriebspartner (siehe www.muething.com) gerne zur
Verfügung.

Our employees or sales partners (see www.muething.com)
are happy to help should you have any further questions on
the technical aspects and use of your implement.

Nos collaborateurs ou nos partenaires commerciaux
(voir www.muething.com) sont à votre entière disposition
pour toutes questions complémentaires relatives aux
caractéristiques techniques ou à l'utilisation de votre engin.

Tanto nuestros empleados como los socios comerciales de la
marca (ver www.muething.com) estamos a su disposición
para atender cualquier consulta técnica o sobre piezas que
pueda tener respecto a su equipo.

The logo for Muething, featuring the word "Muething" in a bold, black, sans-serif font. The letter "u" is stylized with a red dot above it, and the letter "i" has a red dot above it as well. The "t" is also stylized with a red dot above it.

Müthing GmbH & Co. KG Soest
Am Silberberg 23
59494 Soest

Tel +49 (0) 2921 96510
Fax +49 (0) 2921 73080

soest@muething.com

Müthing GmbH & Co. KG Uffenheim
Am Brünlein 2
97215 Uffenheim

Tel +49 (0) 9842 98660
Fax +49 (0) 9842 98667

uffenheim@muething.com

WWW.MUETHING.COM