



ERSATZTEILLISTE | Spare parts list

Liste des pièces de rechange | Lista de repuestos

MU-H VARIO 120 - 220

AB SERIE | as of series | á partir de série | desde de la serie 2015

AUSGABE | edition | version | edición 12.2023

BESTELLCODE | Order code | Code de commande | Código de pedido P_H_ET_23_WEL

Übertragen Sie hier bitte die Daten Ihres Gerätes und des verwendeten Getriebes.

Enter the details for your implement and the gear box you are using here.

Veuillez inscrire ici les références de votre machine et celles du boîtier.

Introduzca aquí los datos de su equipo y la transmisión utilizada.

Müthing <small>GROUP & CO. KG</small> D-59494 Soest		CE	UK CA
Type	MU-H 200		
Artikel Nr.	510501		
Serien Nr.	KA 07		
Baujahr	2023	Gewicht	850 kg

Beispiel Typenschild | Type plate example
Exemple de plaque signalétique | Ejemplo de una placa de características

Benennung Designation Désignation Denominación	Eintrag Entry N° d'enregistrement Registro
Modell Model Modèle Modelo	MU-H VARIO 120 - 220 <input type="checkbox"/> 120 <input type="checkbox"/> 140 <input type="checkbox"/> 150 <input type="checkbox"/> 160 <input type="checkbox"/> 180 <input type="checkbox"/> 200 <input type="checkbox"/> 220
Seriennummer Serial number N° de série Número de serie	
Baujahr Year of manufacture Année de construction Año de construcción	
Getriebetyp Gearbox type Type de Système d'entraînement Tipo de transmisión	
Anbaubock Headstock Attelage Soporte adosado	<input type="checkbox"/> fest fixed fixe fijo <input type="checkbox"/> verschiebbar movable déportable móvil
Händler Dealer Distributeur Concesionario	
Inbetriebnahme am Commissioning date Date de mise en service Fecha de puesta en servicio	

Bei bitte deutlich ankreuzen !

Where there are checkboxes , please check these clearly!

Veuillez cocher les cases lisiblement!

Por favor, marque con una cruz en la casilla !



SEHR GEEHRTER KUNDE,

auf den folgenden Seiten finden Sie eine vollständige Übersicht aller Bauteile Ihres Müthing Mulchgerätes MU-H VARIO 120 - 220. Anhand dieser Unterlage bitten wir Sie benötigte Ersatzteile genau zu identifizieren und mit den nachfolgenden Angaben zu bestellen. Benötigen Sie Hilfe oder weitere Informationen kontaktieren Sie uns.

Vielen Dank - Ihr Müthing-Team

CHER CLIENT,

Vous trouverez sur les pages suivantes une description complète des composants de votre broyeur Müthing MU-H VARIO 120 - 220. Nous vous invitons à identifier exactement les pièces de rechange requises à l'appui de ce document et de les commander en indiquant le n° de référence de pièces de rechange. N'hésitez pas à nous contacter si vous avez besoin d'aide ou d'informations complémentaires.

Merci beaucoup – Votre équipe Müthing

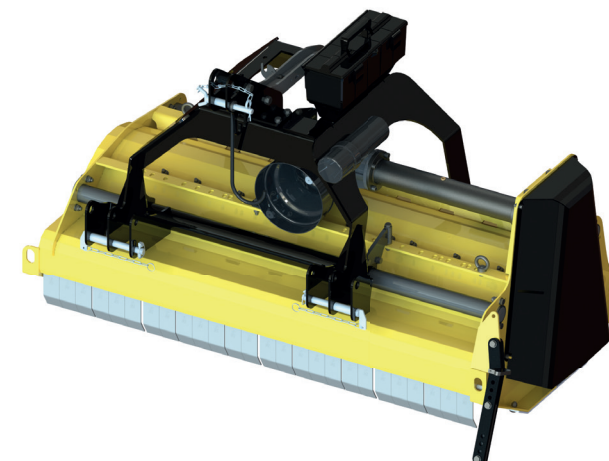

DEAR CUSTOMER,

The following pages offer a complete overview of the components in your Müthing MU-H VARIO 120 - 220 mulcher. We are providing you with this document so that you can identify exactly the spare parts you require and order them using the spare part numbers listed. Should you need any assistance or further information, please contact us.

Kind regards - Your Müthing team

ESTIMADO CLIENTE,

En las siguientes páginas ponemos a su disposición una relación completa de los componentes de su trituradora MU-H VARIO 120 - 220 de Müthing. Le rogamos que con ayuda de este listado identifique las piezas de repuesto necesarias y las encargue con su correspondiente número de repuesto. No dude en ponerse en contacto con nosotros para solicitar ayuda o información ampliada.

Muchas gracias - Su equipo Müthing



Beachten Sie immer die Sicherheitshinweise der Betriebsanleitung !

Always follow the safety instructions in the operating manual.

Veuillez toujours tenir compte des consignes de sécurité figurant dans le manuel d'utilisation !

Observe siempre las indicaciones de seguridad de las instrucciones de servicio !

Einleitung Introduction Introduction Introducción 	3
Grundauführung Basic model Modèle de base Modelo básico 	
Gehäuse Housing Caisson Caja 	6
Kurzhäckselleiste Short chopping bar Lame hache-paille courte Listón de corte de paja corto 	12
Dreipunktbock 3-point trestle Support d'attelage trois point Soporte de tres apoyos 	14
Anbaubock Headstock Tête d'attelage Soporte adosado 	18
Schiebebock Headstock Attelage Soporte adosado 	22
Doppelbock Dual headstock Attelage avant et arrière Duplicado Soporte adosado 	26
Werkzeugkiste Tool box Boîte à outils Caja de herramientas 	30
Antrieb & Getriebe Drive and gear box Transmission et Système d'entraînement Accionamiento e Cambio 	32
Übersetzung Getriebe Gear box translation Système d'entraînement multiplication Cambio la traducción 	36
Hammerrotor Hammer rotor Rotor à marteaux Rotor de martillo 	38
Stützwalze Support roller Rouleau d'appui Cilindro de apoyo 	42
Getriebe Gear box Système d'entraînement Cambio 	44
Getriebe mit doppeltem Freilauf Double freewheel gearbox Système d'entraînement à double roue libre Caja de cambios de rueda libre doble 	48
Sonderzubehör Optional accessory Accessoires optionnels Componentes especiales 	
Gelenkwelle - GE2401 Cardan shaft - GE2401 Arbre de transmissio - GE2401 Árbol de transmisión - GE2401 	50
Abstellstütze Supporting leg Béquille de stationnement Pie de apoyo 	52
Oberlenkeraufnahme kurz Upper link receiver short Logement du bras supérieur court Alojamiento del brazo superior corto 	54
Verlängerung Unterlenker Kat.1 Extension lower link Kat.1 Rallonge du bras inférieur Kat.1 Prolongación de la brazo inferior Kat.1 	56
Verlängerung Unterlenker Kat.2 Extension lower link Kat.2 Rallonge du bras inférieur Kat.2 Prolongación de la brazo inferior Kat.2 	58
Verschiebeentlastung Displacement relief Relief décalage Alivio de desplazamiento 	60
Hydraulische Seitenverschiebung Hydraulic side shift Déport latéral hydraulique Desplazamiento lateral hidráulico 	62
Schäkelrotor Shackle rotor Rotor manilles Grillete rotor 	64
Y-Messerrotor Y-blade rotor Y-lame rotor Rotor con cuchilla en Y 	66
2.Kurzhäckselleiste 2.Short chopping bar 2.Lame hache-paille courte 2.Listón de corte de paja corto 	70
Schneidschiene Cutting bar Contre-lame réglable Carril de corte 	72

Verschleißeinlage Wear insert Blindage Junta de desgaste 	74
Verschleißkufen Wear runner Patin d' usure Cuchilla de desgaste 	76
Betriebsstundenzähler Operating hours counter Compteur horaire Contador de horas de servicio 	78
Beleuchtungsträger Lighting equipment Support d' éclairage Soporte de alumbrado 	80
Warntafel mit Beleuchtungseinrichtung Warning sign with lighting equipment Panneau de signalisation avec système d' éclairage Panel de aviso con dispositivo de iluminación 	82
Insektenretter Insect rescuer Sauveteur d'insectes Protector para insectos 	84
Insektenretter hydr.klappbar Insect rescuer hydraulic foldable Sauveteur d'insectes hydraulique pliable Protector para insectos hidráulico plegable 	88
Federentlastungspaket Shock-absorbing spring assembly Lot de ressorts d'allègement Conjunto de muelle de compensación 	90
Hydraulische Druckentlastung MU-SOFA mobil Hydraulic pressure relief MU-SOFA mobile Délestage hydraulique MU-SOFA mobil Descarga de presión hidráulica MU-SOFA móvil 	92
Hydraulikbaugruppe MU-SOFA mobil Hydraulic assembly MU-SOFA mobile Assemblage hydraulique MU-SOFA mobil Ensemble hidráulico MU-SOFA móvil 	94



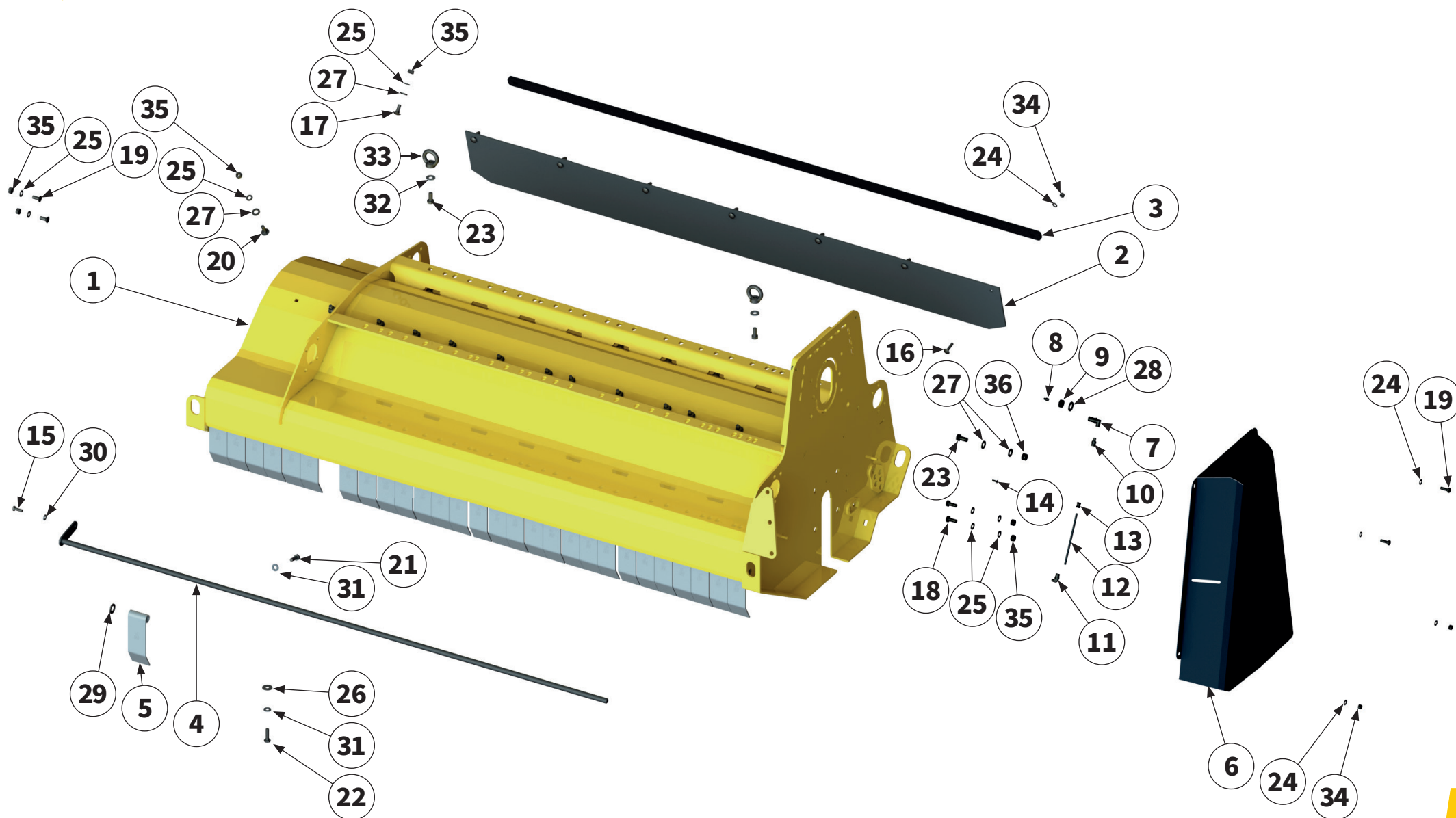

Pos.- Nr. No. Número Número	Ersatzteilnummer Manufacturer part number Numéro d'article du fabricant Número de pieza del fabricante							DE Bezeichnung	EN Designation	FR Désignation	ES Designación
	Anzahl quantity quantité número										
	MU-H 120	MU-H 140	MU-H 150	MU-H 160	MU-H 180	MU-H 200	MU-H 220				
1	00013878 1	00013883 1	00013888 1	00013893 1	00013897 1	00013902 1	00018302 1	Gehäuse	housing	Caisson	Caja
2	1,25 m	1,45 m	1,55 m	PO.300 1,65 m	1,85 m	2,05 m	2,25 m	Schutzgummi	guard	Protection	Protección
3	00010661 1	00010660 1	00010659 1	00005648 1	00004779 1	00005660 1	00006737 1	Klemmleiste	support plate	Tôle de support	Bloque de terminales
4	00001124 1	00001374 1	00005642 1	00001798 1	00004784 1	00005640 1	00005638 1	Pendelwelle	pendelum shaft	Arbre pendulaire	Eje del péndulo
5	19	23	24	00001058 26	29	33	36	Pendelklappe	flap with swing protection	Volvet de protection	Tapa protectora del péndulo
6	1	1	1	00014413 1	1	1	1	Schutzabdeckung	protective cover	Recouvrement de protection	Cubierta protectora
7	1	1	1	00017522 1	1	1	1	Winkelverbinder	elbow connector	Connecteur d'angle	Escuadra de unión
8	2	2	2	00043301 2	2	2	2	Schmiernippel	lubricating nipple	Nipple de graissage	Engrasador
9	1	1	1	00043172 1	1	1	1	Mutter	nut	Écrou	Tuerca
10	1	1	1	00044548 1	1	1	1	Verschraubung	threaded connection	Raccord à vis	Unión atornillada
11	0,43m	0,43m	0,43m	00044550 0,43m	0,43m	0,43m	0,43m	Verschraubung	threaded connection	Raccord à vis	Unión atornillada
12	1	1	1	00044936 1	1	1	1	Schmierleitung	lubrication line	Conduite de graissage	Tubería de engrase
13	1	1	1	00044539 1	1	1	1	Schelle	clamp	Collier	Abrazadera
14	1	1	1	00015087 1	1	1	1	Blindniet	pop rivet	Rivet aveugle	Remache ciego
15	3	3	3	00043709 3	3	3	3	Schraube	bolt	Vis	Tornillo

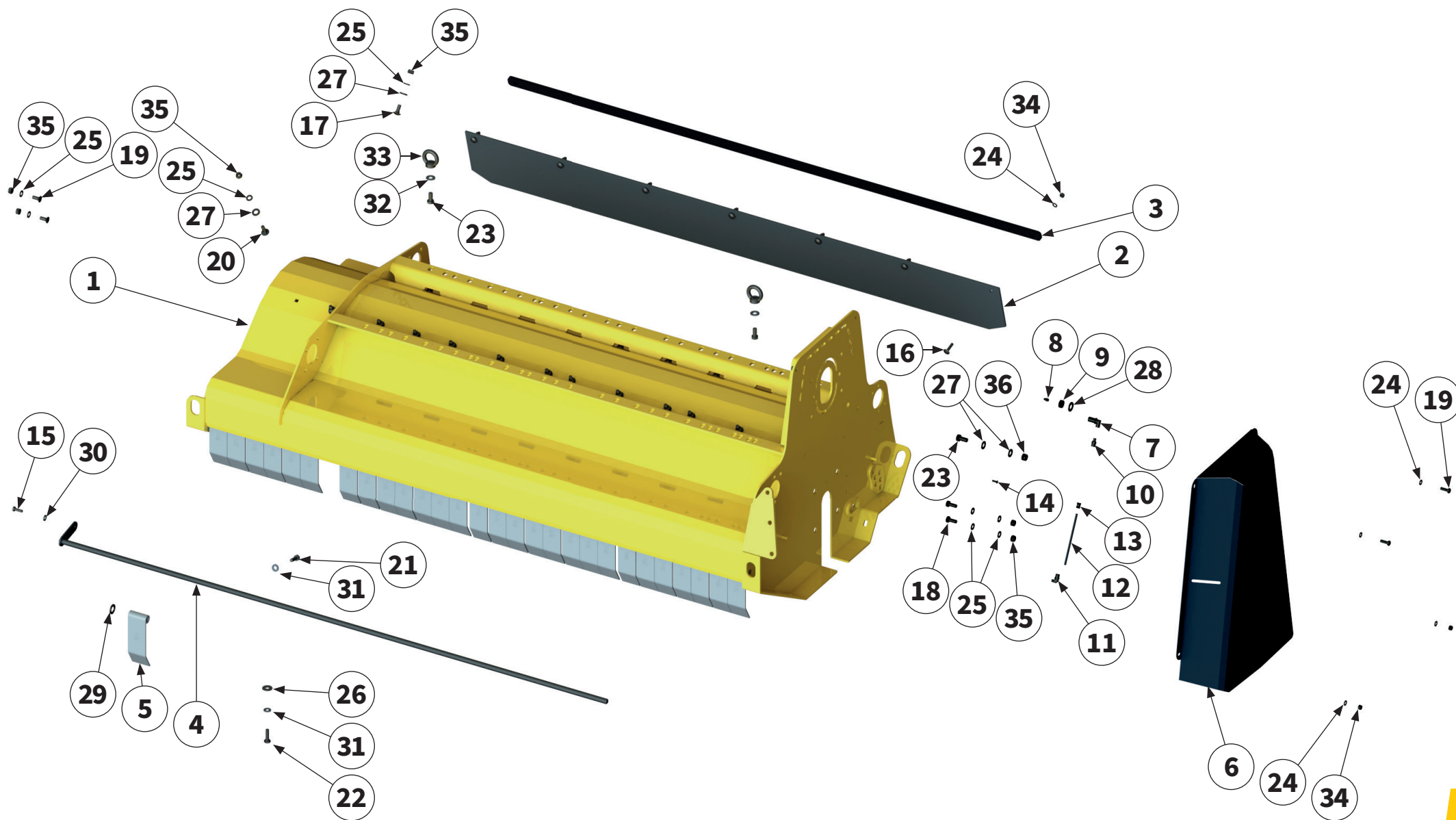

Pos.- Nr. No. Número	Ersatzteilnummer Manufacturer part number Numéro d'article du fabricant Número de pieza del fabricante							DE Bezeichnung	EN Designation	FR Désignation	ES Designación
	Anzahl quantity quantité número										
	MU-H 120	MU-H 140	MU-H 150	MU-H 160	MU-H 180	MU-H 200	MU-H 220				
16	6	6	7	7	7	8	9	Schraube	bolt	Vis	Tornillo
17	8	10	19	11	13	14	16	Schraube	bolt	Vis	Tornillo
18	2	2	2	2	2	2	2	Schraube	bolt	Vis	Tornillo
19	2	2	2	2	2	2	-	Schraube	bolt	Vis	Tornillo
20	8	10	10	11	13	14	16	Schraube	bolt	Vis	Tornillo
21	8	10	10	11	13	14	16	Schraube	bolt	Vis	Tornillo
22	8	8	10	10	10	12	12	Schraube	bolt	Vis	Tornillo
23	3	3	3	3	3	3	3	Schraube	bolt	Vis	Tornillo
24	12	12	13	13	13	14	15	Scheibe	washer	Disque	Arandela
25	22	26	26	28	32	34	36	Scheibe	washer	Disque	Arandela
26	8	8	10	10	10	12	12	Scheibe	washer	Disque	Arandela
27	18	22	22	24	28	30	34	Scheibe	washer	Disque	Arandela
28	1	1	1	1	1	1	1	Scheibe	washer	Disque	Arandela
29	14	2	14	8	14	2	10	Scheibe	washer	Disque	Arandela
30	1	1	1	1	1	1	1	Scheibe	washer	Disque	Arandela

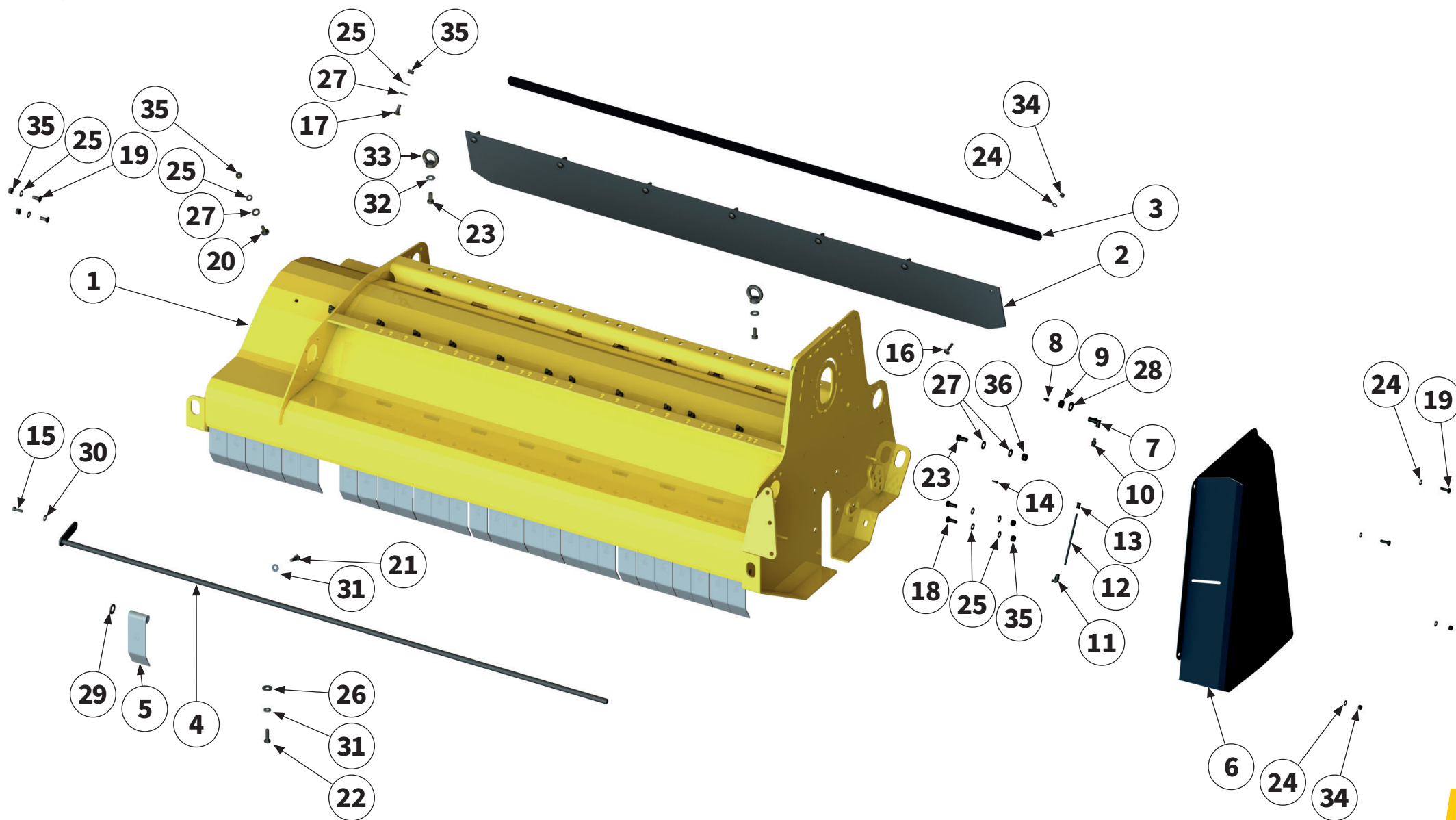

Pos.- Nr. No. Numéro Número	Ersatzteilnummer Manufacturer part number Numéro d'article du fabricant Número de pieza del fabricante							DE Bezeichnung	EN Designation	FR Désignation	ES Designación
	Anzahl quantity quantité número										
	MU-H 120	MU-H 140	MU-H 150	MU-H 160	MU-H 180	MU-H 200	MU-H 220				
31	16	18	20	00043766 21	23	26	28	Scheibe	washer	Disque	Arandela
32	2	2	2	00043767 2	2	2	2	Scheibe	washer	Disque	Arandela
33	2	2	2	00043145 2	2	2	2	Ringmutter	ring nut	Écrou annulaire	Tuerca anular
34	10	10	11	00043191 11	11	20	13	Mutter	nut	Écrou	Tuerca
35	28	24	24	00043177 26	30	32	34	Mutter	nut	Écrou	Tuerca
36	1	1	1	00043178 1	1	1	1	Mutter	nut	Écrou	Tuerca



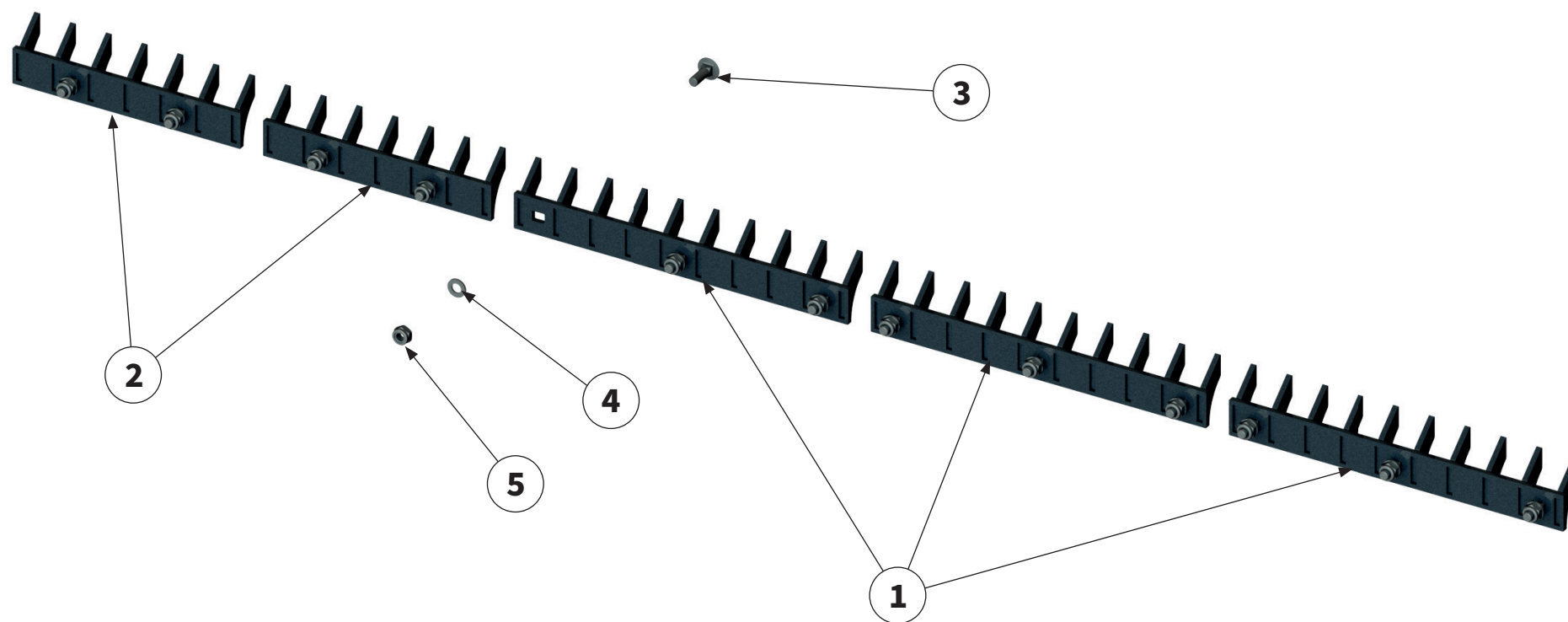

Pos.-Nr. No. Numéro Número	Ersatzteilnummer Manufacturer part number Numéro d'article du fabricant Número de pieza del fabricante							DE Bezeichnung	EN Designation	FR Désignation	ES Designación
	Anzahl quantity quantité número										
	MU-H 120	MU-H 140	MU-H 150	MU-H 160	MU-H 180	MU-H 200	MU-H 220				
Maschine mit Hammerrotor Machine with Hammer rotor Machine avec Rotor à marteaux Máquina con Rotor de martillo 											
1	2	2	-	3	3	4	4	Gegen- schneide 400	short-chopping bar	Lame hache- paille courte	Listón de corte de paja corto
2	1	2	5	1	2	1	2	Gegen- schneide 300	short-chopping bar	Lame hache- paille courte	Listón de corte de paja corto
3	8	10	10	11	13	14	16	Schraube	bolt	Vis	Tornillo
4	8	10	10	11	13	14	16	Scheibe	washer	Disque	Arandela
5	8	10	10	11	13	14	16	Mutter	nut	Ècrou	Tuerca
Maschine mit Schäkelrotor Machine with Shackle rotor Machine avec Rotor à manilles Máquina con Rotor de grilletes 											
1	2	2	-	3	3	4	4	Gegen- schneide 400	short-chopping bar	Lame hache- paille courte	Listón de corte de paja corto
2	1	2	5	1	2	1	2	Gegen- schneide 300	short-chopping bar	Lame hache- paille courte	Listón de corte de paja corto
3	8	10	10	11	13	14	16	Schraube	bolt	Vis	Tornillo
4	8	10	10	11	13	14	16	Scheibe	washer	Disque	Arandela
5	8	10	10	11	13	14	16	Mutter	nut	Ècrou	Tuerca



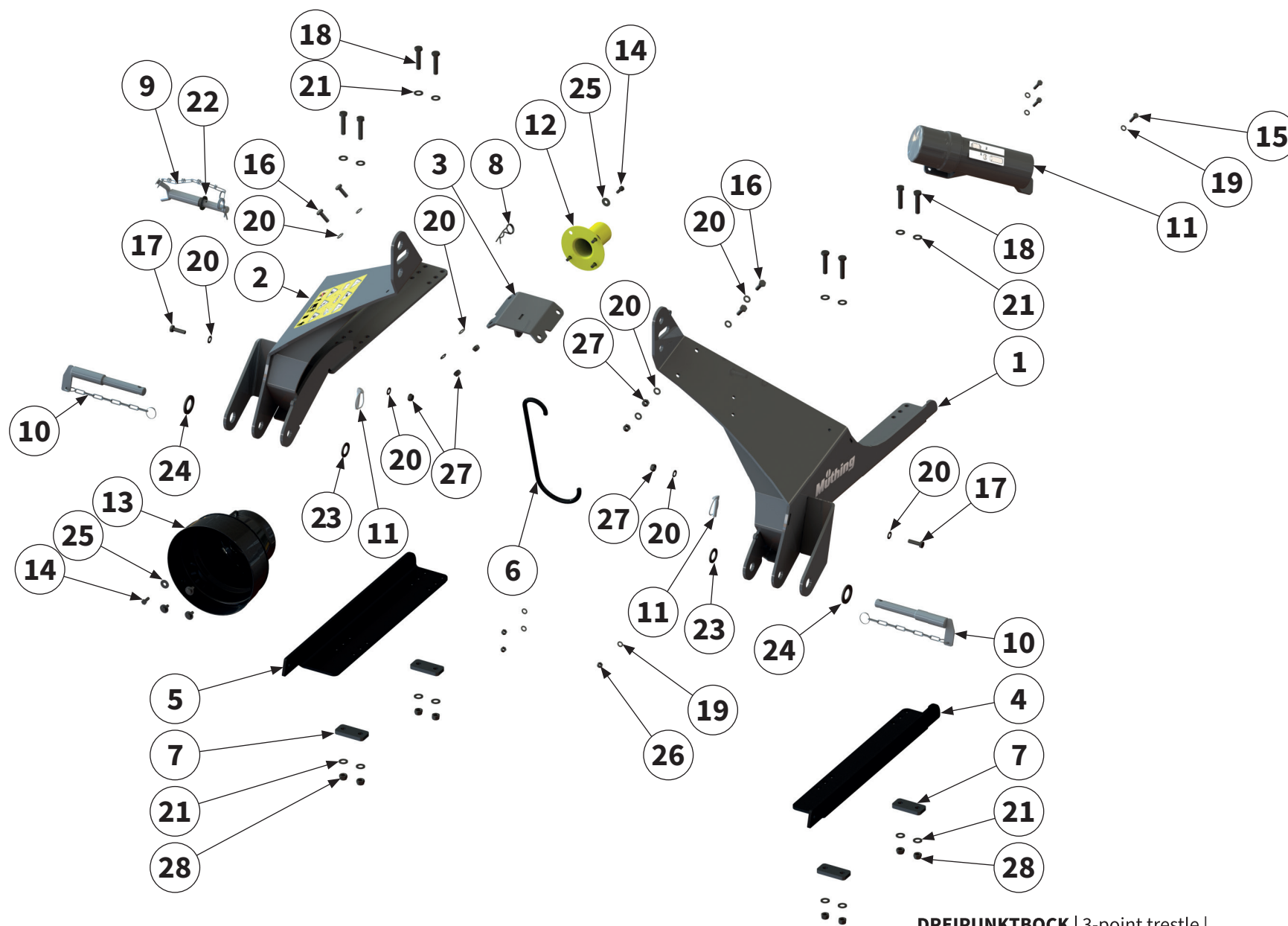

DREIPUNKTBOCK | 3-point trestle |
 Support d'attelage trois point | Soporte de tres apoyos |

Pos.- Nr. No. Numéro Número	Ersatzteilnummer Manufacturer part number Numéro d'article du fabricant Número de pieza del fabricante							DE Bezeichnung	EN Designation	FR Désignation	ES Designación
	Anzahl quantity quantité número										
	MU-H 120	MU-H 140	MU-H 150	MU-H 160	MU-H 180	MU-H 200	MU-H 220				
1	00014256 1 1 1 1 1 1 1 Fahrtrichtung links Direction of travel left Dans le sens de la marche á gauche En sentido de marcha a la izquierda							Anbaubock	headstock	Attelage	Soporte adosado
2	00014259 1 1 1 1 1 1 1 Fahrtrichtung rechts Direction of travel right Dans le sens de la marche á droite En sentido de la marcha a la derecha							Anbaubock	headstock	Attelage	Soporte adosado
3	00015877 1 1 1 1 1 1 1							Verbindungsblech	connecting plate	Tôle de connexion	Chapa de conexión
4	00042483 1 1 1 1 1 1 1							Verstärkung	reinforcement	Renforcement	Reforzamiento
5	00042499 1 1 1 1 1 1 1							Verstärkung	reinforcement	Renforcement	Reforzamiento
6	00013944 1 1 1 1 1 1 1							Halter	holder	Support	Soporte
7	00014496 4 4 4 4 4 4 4							Platte	plate	Plaque	Placa
8	00044564 1 1 1 1 1 1 1							Sicherungselement	locking element	Élément de sécurité	Elemento de seguridad
9	00013949 1 1 1 1 1 1 1							Bolzen mit Kette	pin with chain	Boulon à chaîne	Perno con cadena
10	00001262 1 1 1 1 1 1 1							Bolzen mit Kette	pin with chain	Boulon à chaîne	Perno con cadena
11	00034497 1 1 1 1 1 1 1							Dokumentenrolle	document roll	Document rouleau	Rollo de documento
12	00044553 1 1 1 1 1 1 1							Schutztopf	protective pot	Barillet de protection	Tapa de protección
13	00044556 1 1 1 1 1 1 1							Schutztopf	protective pot	Barillet de protection	Tapa de protección

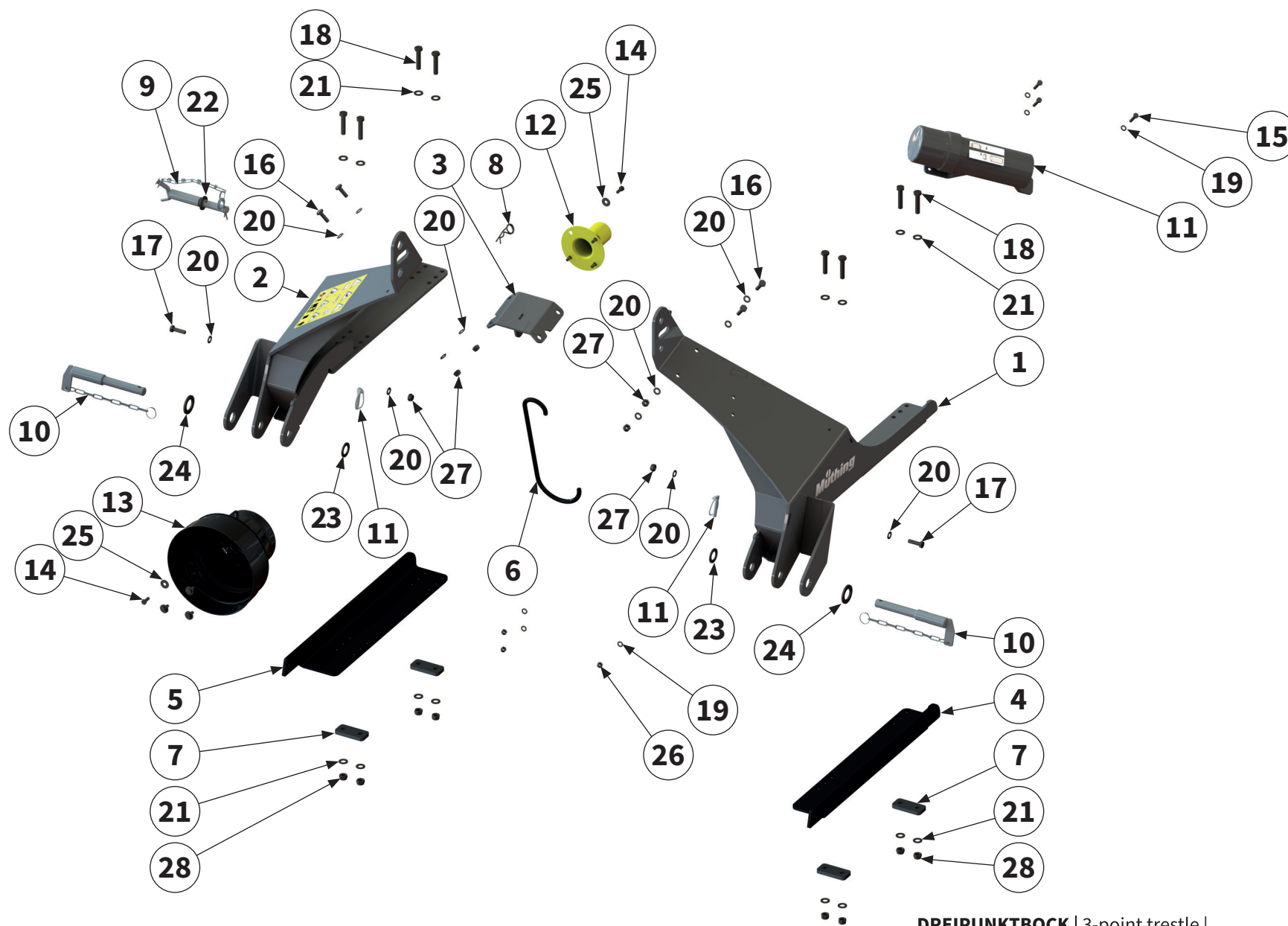

Pos.- Nr. No. Numéro Número	Ersatzteilnummer Manufacturer part number Numéro d'article du fabricant Número de pieza del fabricante							DE Bezeichnung	EN Designation	FR Désignation	ES Designación
	Anzahl quantity quantité número										
	MU-H 120	MU-H 140	MU-H 150	MU-H 160	MU-H 180	MU-H 200	MU-H 220				
14	8	8	8	00043708 8	8	8	8	Schraube	bolt	Vis	Tornillo
15	3	3	3	00043710 3	3	3	3	Schraube	bolt	Vis	Tornillo
16	4	4	4	00043602 4	4	4	4	Schraube	bolt	Vis	Tornillo
17	2	2	2	00043603 2	2	2	2	Schraube	bolt	Vis	Tornillo
18	8	8	8	00043625 8	8	8	8	Schraube	bolt	Vis	Tornillo
19	6	6	6	00043249 6	6	6	6	Scheibe	washer	Disque	Arandela
20	12	12	12	00043232 12	12	12	12	Scheibe	washer	Disque	Arandela
21	16	16	16	00043233 16	16	16	16	Scheibe	washer	Disque	Arandela
22	1	1	1	00043237 1	1	1	1	Scheibe	washer	Disque	Arandela
23	2	2	2	00043238 2	2	2	2	Scheibe	washer	Disque	Arandela
24	2	2	2	00043242 2	2	2	2	Scheibe	washer	Disque	Arandela
25	8	8	8	00043286 8	8	8	8	Scheibe	washer	Disque	Arandela
26	3	3	3	00043191 3	3	3	3	Mutter	nut	Ècrou	Tuerca
27	6	6	6	00043177 6	6	6	6	Mutter	nut	Ècrou	Tuerca
28	8	8	8	00043178 8	8	8	8	Mutter	nut	Ècrou	Tuerca

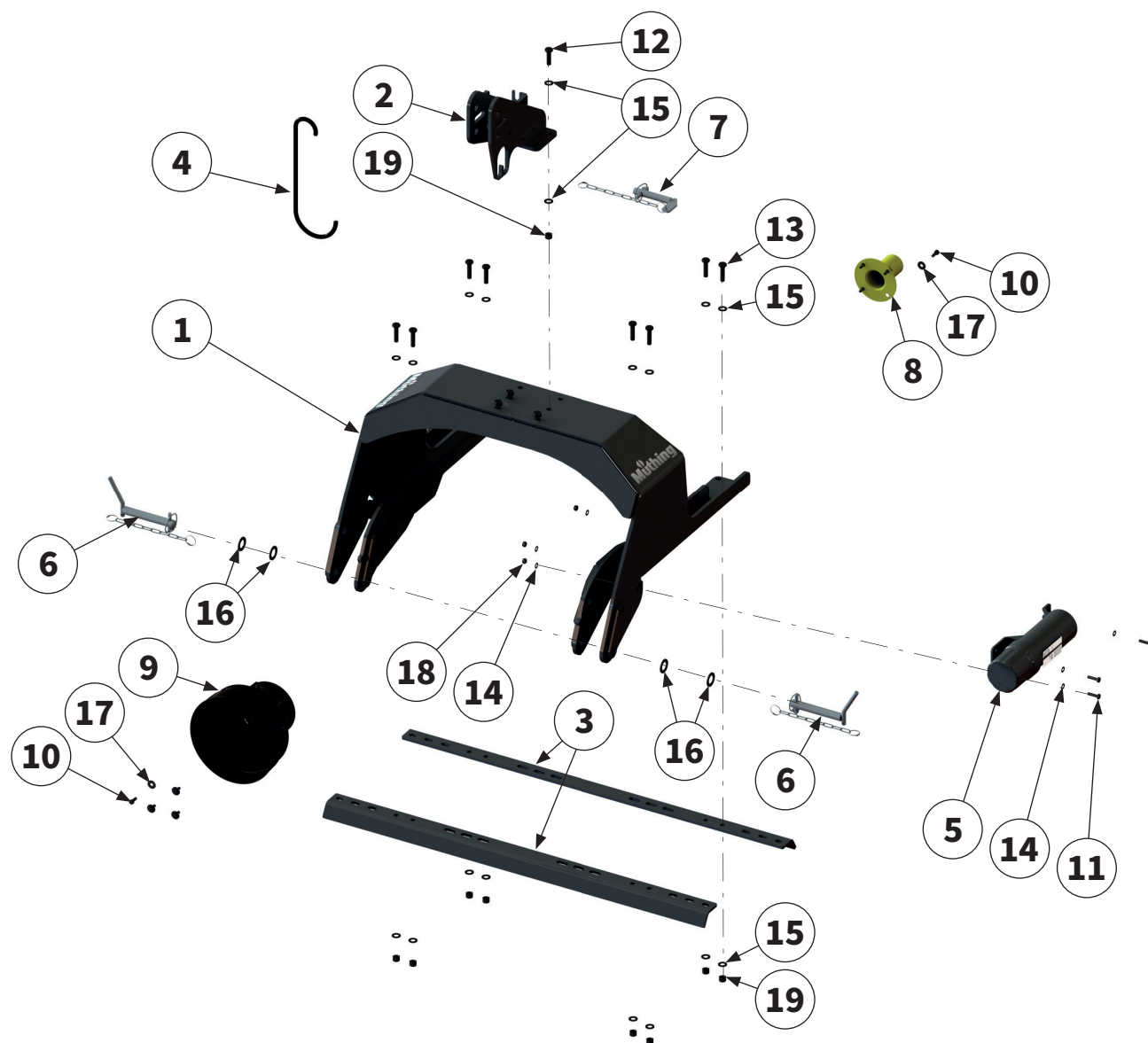

Pos.-Nr. No. Número Número	Ersatzteilnummer Manufacturer part number Numéro d'article du fabricant Número de pieza del fabricante							DE Bezeichnung	EN Designation	FR Désignation	ES Designación	
	Anzahl quantity quantité número											
	MU-H 120	MU-H 140	MU-H 150	MU-H 160	MU-H 180	MU-H 200	MU-H 220					
1	1	1	1	0003608 1	1	1	1	1	Anbaubock	headstock	Tête d'attelage	Soporte adosado
2	1	1	1	00014428 1	1	1	1	1	Oberlenkeraufnahme	upper link receiver	Logement du bras supérieur	Alojamiento del brazo superior
3	00046097 2	2	2	00014429 2	2	2	2	2	Blech	sheet metal	Tôle	Chapa
4	1	1	1	00013944 1	1	1	1	1	Halter	holder	Support	Soporte
5	1	1	1	00034497 1	1	1	1	1	Dokumentenrolle	document roll	Document rouleau	Rollo de documento
6	2	2	2	00044076 2	2	2	2	2	Bolzen mit Kette	pin with chain	Boulon à chaîne	Perno con cadena
7	1	1	1	00005545 1	1	1	1	1	Bolzen mit Kette	pin with chain	Boulon à chaîne	Perno con cadena
8	1	1	1	00044553 1	1	1	1	1	Schutztopf	protective pot	Barillet de protection	Tapa de protección
9	1	1	1	00044556 1	1	1	1	1	Schutztopf	protective pot	Barillet de protection	Tapa de protección
10	8	8	8	00043708 8	8	8	8	8	Schraube	bolt	Vis	Tornillo
11	3	3	3	00043710 3	3	3	3	3	Schraube	bolt	Vis	Tornillo
12	4	4	4	00043622 4	4	4	4	4	Schraube	bolt	Vis	Tornillo
13	8	8	8	00043623 8	8	8	8	8	Schraube	bolt	Vis	Tornillo
14	6	6	6	00043249 6	6	6	6	6	Scheibe	washer	Disque	Arandela



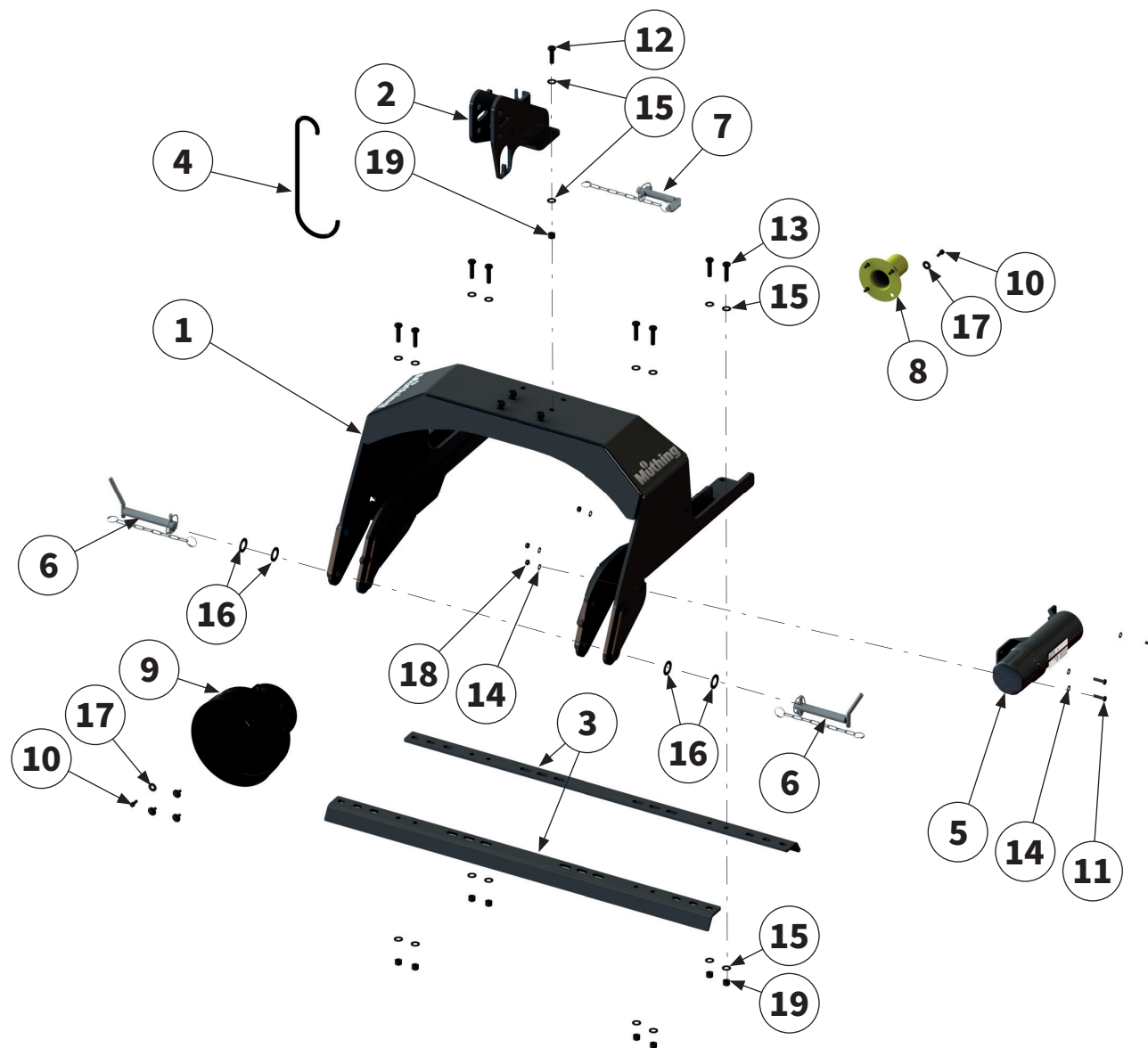

Pos.-Nr. No. Numéro Número	Ersatzteilnummer Manufacturer part number Numéro d'article du fabricant Número de pieza del fabricante							DE Bezeichnung	EN Designation	FR Désignation	ES Designación
	Anzahl quantity quantité número										
	MU-H 120	MU-H 140	MU-H 150	MU-H 160	MU-H 180	MU-H 200	MU-H 220				
15	24	24	24	00043233 24	24	24	24	Scheibe	washer	Disque	Arandela
16	4	4	4	00043238 4	4	4	4	Scheibe	washer	Disque	Arandela
17	8	8	8	00043286 8	8	8	8	Scheibe	washer	Disque	Arandela
18	3	3	3	00043191 3	3	3	3	Mutter	nut	Écrou	Tuerca
19	12	12	12	00043178 12	12	12	12	Mutter	nut	Écrou	Tuerca

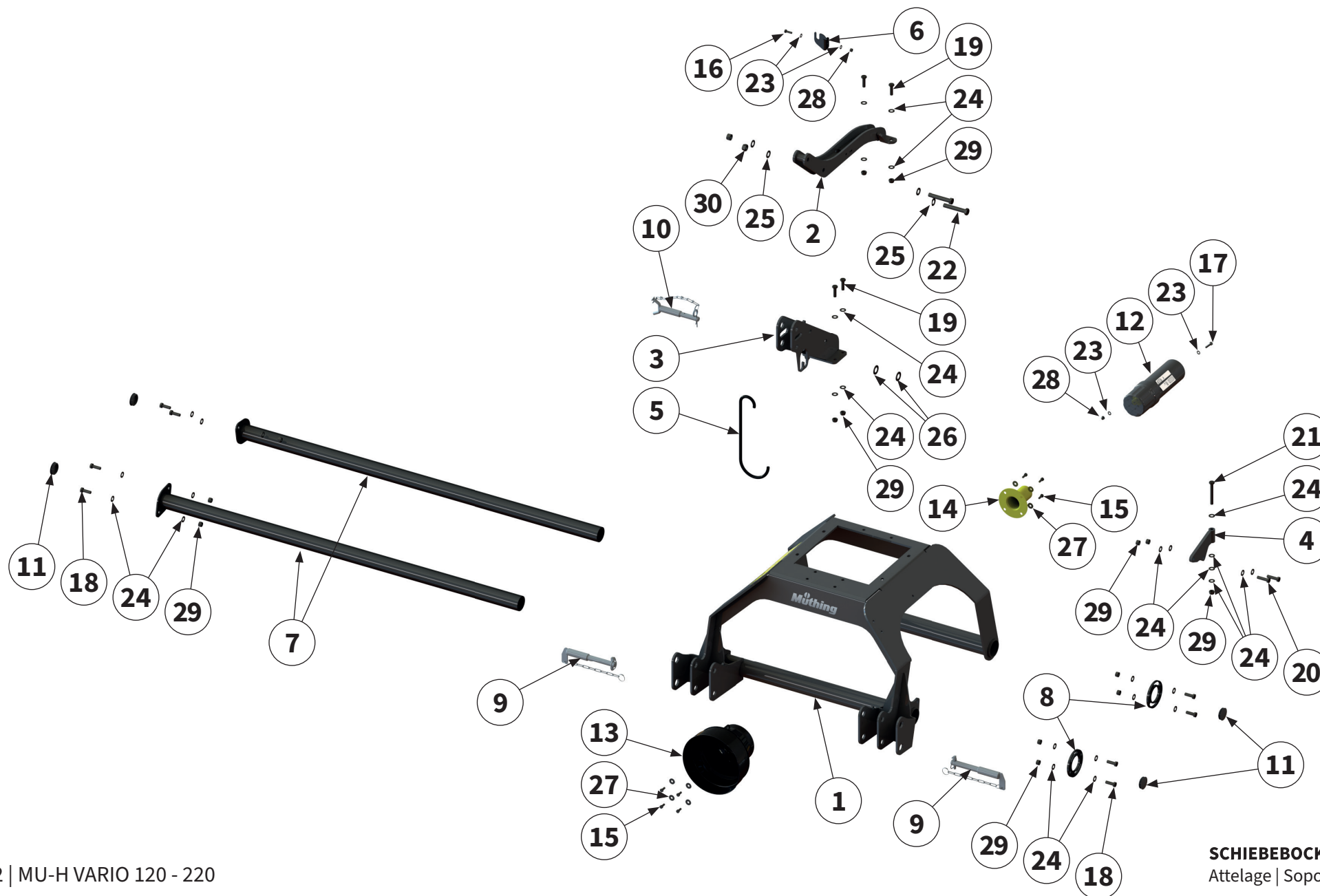

Pos.-Nr. No. Número Número	Ersatzteilnummer Manufacturer part number Numéro d'article du fabricant Número de pieza del fabricante							DE Bezeichnung	EN Designation	FR Désignation	ES Designación	
	Anzahl quantity quantité número											
	MU-H 120	MU-H 140	MU-H 150	MU-H 160	MU-H 180	MU-H 200	MU-H 220					
1	-	1	1	00013961			1	00012451	Schiebebock	headstock	Attelage	Soporte adosado
2	-	1	1	00019480			1	00012451	Versteifungsstrebe	reinforcing strut	Tirant de renforcement	Tirante
3	-	1	1	00013953			1	00012312	Oberlenkeraufnahme	upper link receiver	Logement du bras supérieur	Alojamiento del brazo superior
4	-	1	1	00013934			1	00012451	Bolzenhalter	pin holder	Axe Support	Perno Soporte
5	-	1	1	00013944			1	00012451	Halter	holder	Support	Soporte
6	-	1	1	00013943			1	00012451	Hakenhalter	hook holder	Support á crochets	Títul de gancho
7	-	00014471		00010642		00014423		00014423	Verschieberohr	circular pipe	Tuyau rond	Tubo redondo
8	-	2	2	00010623			2	00014423	Exzenter-scheibe	eccentric disc	Disque d'excentrique	Disco excéntrico
9	-	2	2	00001262			2	00014423	Bolzen mit Kette	pin with chain	Boulon à chaîne	Perno con cadena
10	-	1	1	00013949			1	00014423	Bolzen mit Kette	pin with chain	Boulon à chaîne	Perno con cadena
11	-	4	4	00014452			4	00014418	Verschlussstopfen	sealing plug	Bouchon de fermeture	Tapón de cierre
12	-	1	1	00034497			1	00014423	Dokumentenrolle	document roll	Document rouleau	Rollo de documento
13	-	1	1	00044556			1	00014423	Schutztopf	protective pot	Barillet de protection	Tapa de protección
14	-	1	1	00044553			1	00014423	Schutztopf	protective pot	Barillet de protection	Tapa de protección
15	-	8	8	00043708			8	00014423	Schraube	bolt	Vis	Tornillo

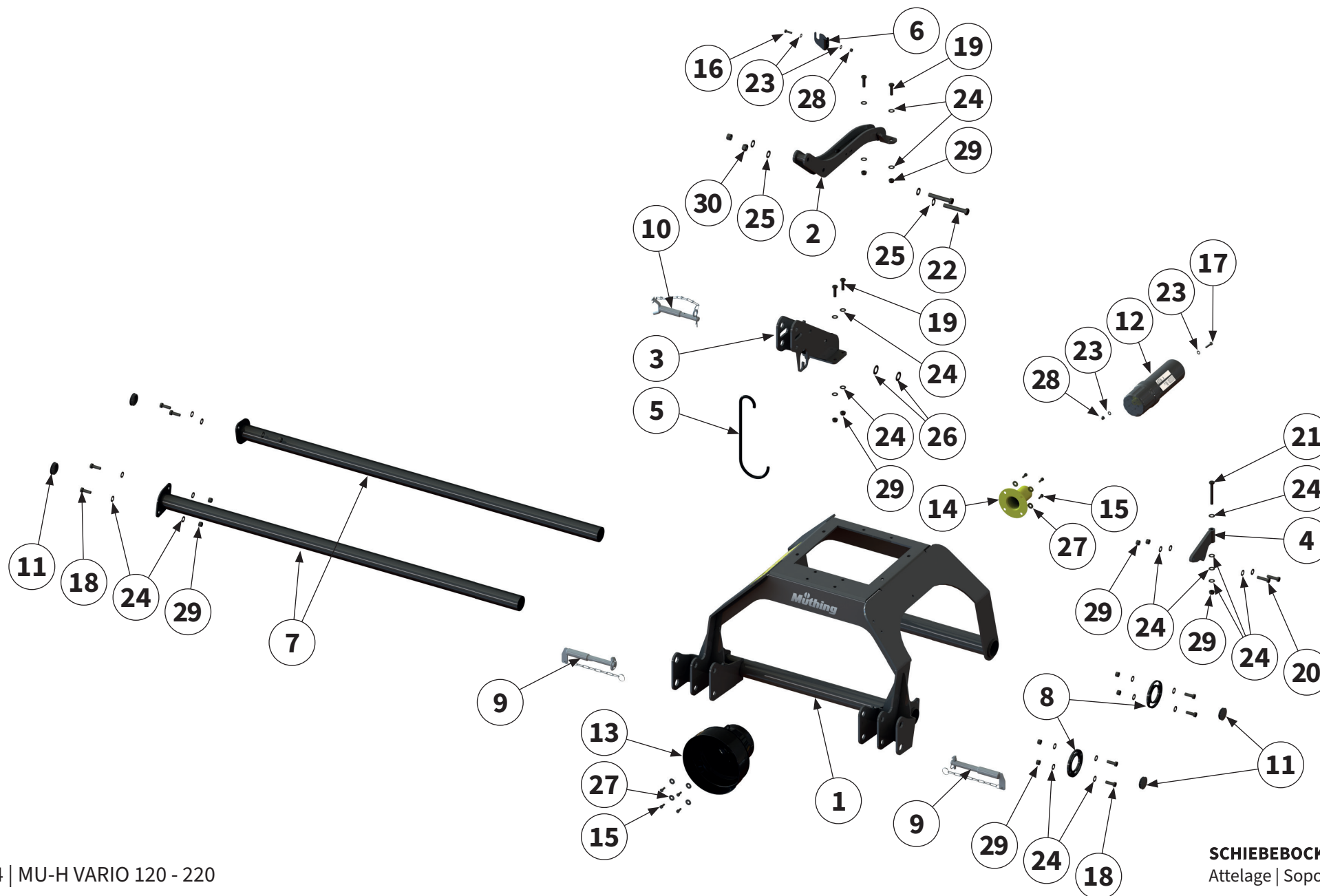

Pos.-Nr. No. Número Número	Ersatzteilnummer Manufacturer part number Numéro d'article du fabricant Número de pieza del fabricante							DE Bezeichnung	EN Designation	FR Désignation	ES Designación	
	Anzahl quantity quantité número											
	MU-H 120	MU-H 140	MU-H 150	MU-H 160	MU-H 180	MU-H 200	MU-H 220					
16	-	1	1	1	1	1	1	Schraube	bolt	Vis	Tornillo	
				00043709								
17	-	3	3	3	3	3	3	Schraube	bolt	Vis	Tornillo	
				00043710								
18	-	8	88	8	8	8	8	Schraube	bolt	Vis	Tornillo	
				00043621			00043428					
19	-	6	6	6	6	6	6	Schraube	bolt	Vis	Tornillo	
				00043622								
20	-	2	2	2	2	2	2	Schraube	bolt	Vis	Tornillo	
				00043623			00043622					
21	-	1	1	1	1	1	1	Schraube	bolt	Vis	Tornillo	
				00043505								
22	-	2	2	2	2	2	2	Schraube	bolt	Vis	Tornillo	
				00043535			00043516					
23	-	8	8	8	8	8	8	Scheibe	washer	Disque	Arandela	
				00043249								
24	-	36	36	36	36	36	36	Scheibe	washer	Disque	Arandela	
				00043233								
25	-	4	4	4	4	4	4	Scheibe	washer	Disque	Arandela	
				00043235								
26	-	2	2	2	2	2	-	Scheibe	washer	Disque	Arandela	
				00043237								
27	-	8	8	8	8	8	8	Scheibe	washer	Disque	Arandela	
				00043286								
28	-	4	4	4	4	4	4	Mutter	nut	Ècrou	Tuerca	
				00043191								
29	-	17	17	17	17	17	17	Mutter	nut	Ècrou	Tuerca	
				00043178								
30	-	2	2	2	2	2	2	Mutter	nut	Ècrou	Tuerca	
				00043180								

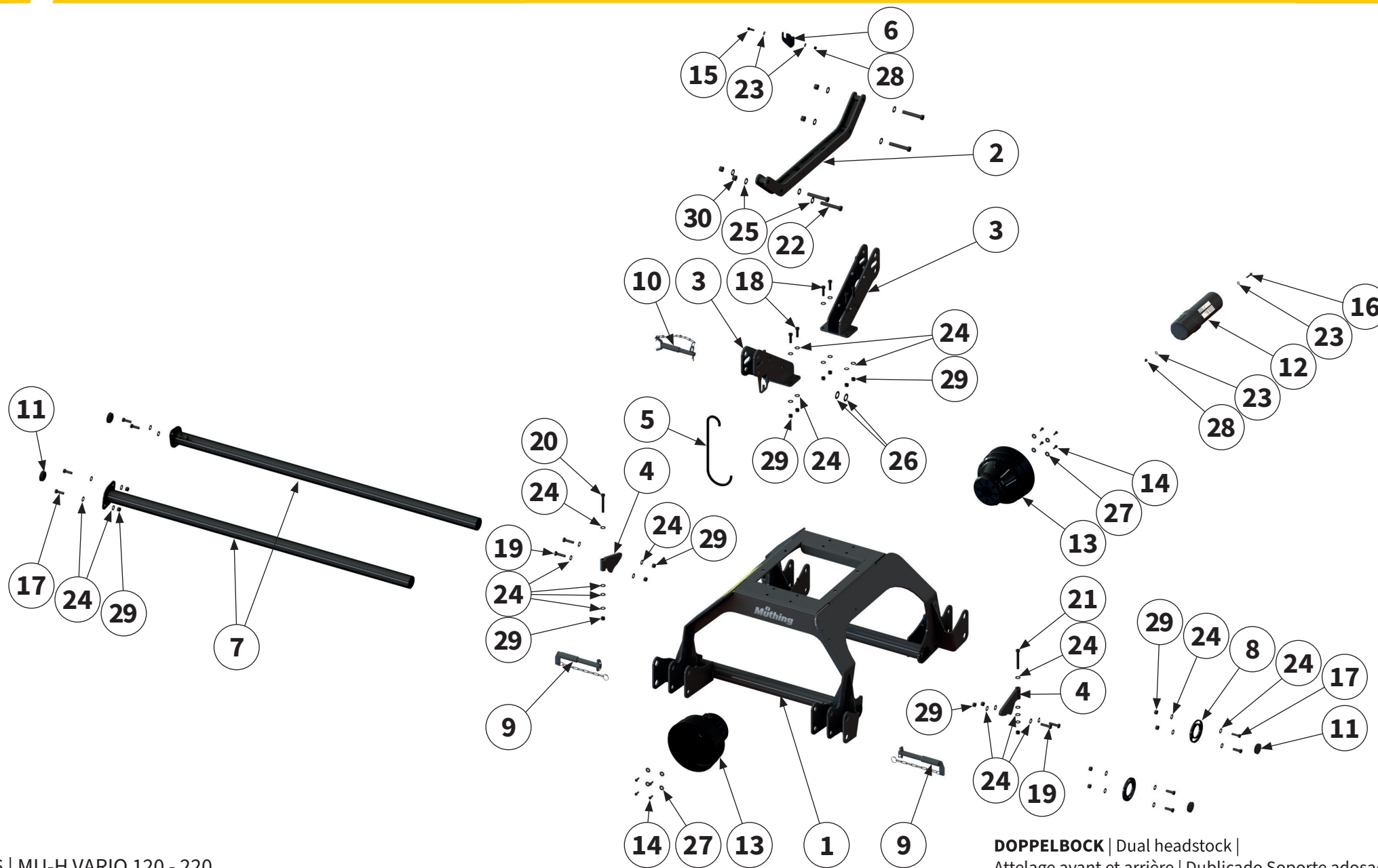

DOPPELBOCK | Dual headstock |
 Attelage avant et arrière | Duplicado Soporte adosado |

Pos.- Nr. No. Numéro Número	Ersatzteilnummer Manufacturer part number Numéro d'article du fabricant Número de pieza del fabricante							DE Bezeichnung	EN Designation	FR Désignation	ES Designación		
	Anzahl quantity quantité número												
	MU-H 120	MU-H 140	MU-H 150	MU-H 160	MU-H 180	MU-H 200	MU-H 220						
1	-	1	1	00013942			1	00012319	1	Doppelbock	dual headstock	Attelage Avant et Arrière	Soporte doble
2	-	1	1	00037207			1	00012319	1	Versteifungsstrebe	reinforcing strut	Tirant de renforcement	Tirante
3	-	2	2	00013953			2	00012312	2	Oberlenkeraufnahme	upper link receiver	Logement du bras supérieur	Alojamiento del brazo superior
4	-	2	2	00013934			2	00012312	2	Bolzenhalter	pin holder	Axe Support	Perno Soporte
5	-	1	1	00013944			1	00012312	1	Halter	holder	Support	Soporte
6	-	1	1	00013943			1	00012312	1	Hakenhalter	hook holder	Support á crochets	Titul de gancho
7	-	00014471		00010642		2	00014423	2	2	Verschieberohr	circular pipe	Tuyau rond	Tube redondo
8	-	2	2	00010623			2	00014423	2	Exzenter-scheibe	eccentric disc	Disque d'excentrique	Disco excéntrico
9	-	2	2	00001262			2	00014423	2	Bolzen mit Kette	pin with chain	Boulon à chaîne	Perno con cadena
10	-	1	1	00013949			1	00014423	1	Bolzen mit Kette	pin with chain	Boulon à chaîne	Perno con cadena
11	-	4	4	00014452			4	00014418	4	Verschlussstopfen	sealing plug	Bouchon de fermeture	Tapón de cierre
12	-	1	1	00034497			1	00014418	1	Dokumentenrolle	document roll	Document rouleau	Rollo de documento
13	-	2	2	00044556			2	00014418	2	Schutztopf	protective pot	Barillet de protection	Tapa de protección
14	-	8	8	00043708			8	00014418	8	Schraube	bolt	Vis	Tornillo
15	-	1	1	00043709			1	00014418	2	Schraube	bolt	Vis	Tornillo

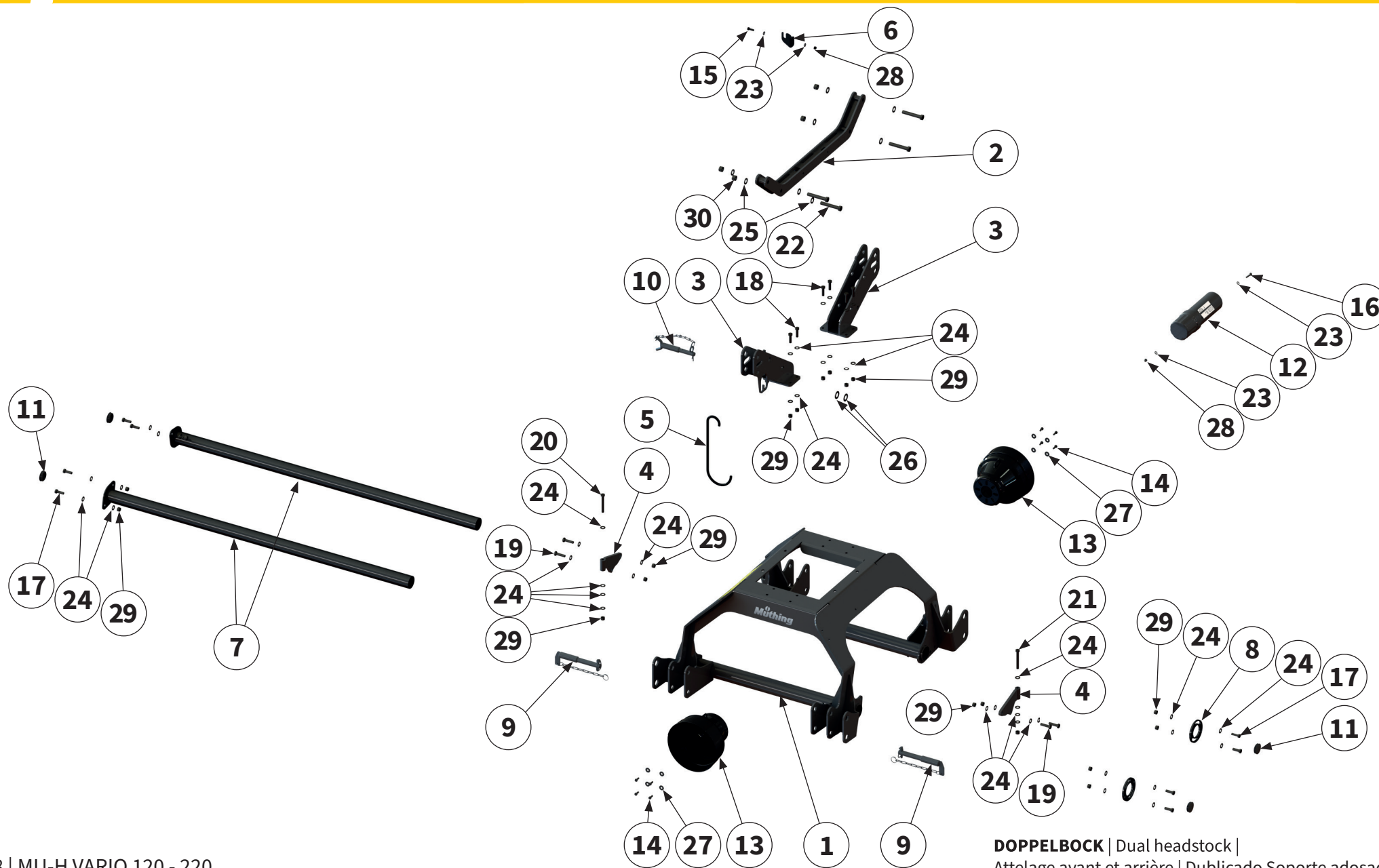

Pos.-Nr. No. Número Número	Ersatzteilnummer Manufacturer part number Numéro d'article du fabricant Número de pieza del fabricante							DE Bezeichnung	EN Designation	FR Désignation	ES Designación
	Anzahl quantity quantité número										
	MU-H 120	MU-H 140	MU-H 150	MU-H 160	MU-H 180	MU-H 200	MU-H 220				
16	-	3	3	3	3	3	3	Schraube	bolt	Vis	Tornillo
17	-	8	8	8	8	8	8	Schraube	bolt	Vis	Tornillo
18	-	8	8	8	8	8	8	Schraube	bolt	Vis	Tornillo
19	-	4	4	4	4	4	4	Schraube	bolt	Vis	Tornillo
20	-	1	1	1	1	1	2	Schraube	bolt	Vis	Tornillo
21	-	1	1	1	1	1	-	Schraube	bolt	Vis	Tornillo
22	-	4	4	4	4	4	4	Schraube	bolt	Vis	Tornillo
23	-	8	8	8	8	8	10	Scheibe	washer	Disque	Arandela
24	-	48	48	48	48	48	54	Scheibe	washer	Disque	Arandela
25	-	8	8	8	8	8	8	Scheibe	washer	Disque	Arandela
26	-	2	2	2	2	2	2	Scheibe	washer	Disque	Arandela
27	-	8	8	8	8	8	8	Scheibe	washer	Disque	Arandela
28	-	4	4	4	4	4	5	Mutter	nut	Ècrou	Tuerca
29	-	22	22	22	22	22	22	Mutter	nut	Ècrou	Tuerca
30	-	4	4	4	4	4	4	Mutter	nut	Ècrou	Tuerca

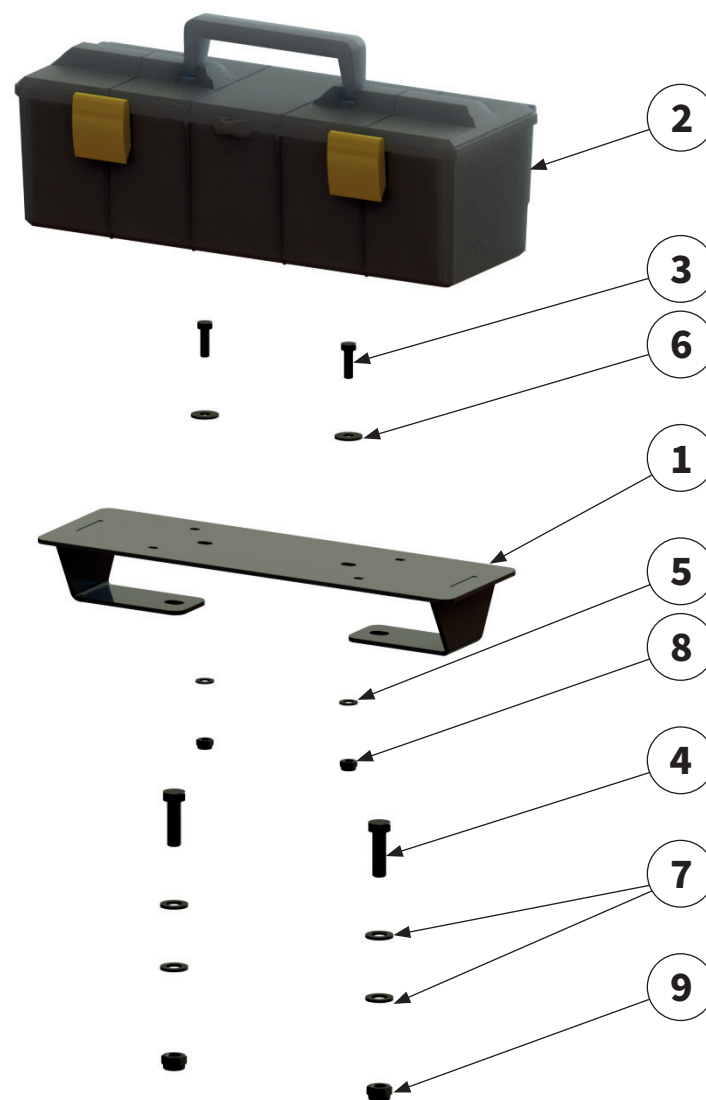

Pos.-Nr. No. Numéro Número	Ersatzteilnummer Manufacturer part number Número d' article du fabricant Número de pieza del fabricante							DE Bezeichnung	EN Designation	FR Désignation	ES Designación
	Anzahl quantity quantité número										
	MU-H 120	MU-H 140	MU-H 150	MU-H 160	MU-H 180	MU-H 200	MU-H 220				
1	1	1	1	1	1	1	1	Halter	holder	Support	Soporte
2	1	1	1	1	1	1	1	Werkzeugkiste	tool box	Boîte à outils	Caja de herramientas
3	2	2	2	2	2	2	2	Schraube	bolt	Vis	Tornillo
4	2	2	2	2	2	2	2	Schraube	bolt	Vis	Tornillo
5	2	2	2	2	2	2	2	Scheibe	washer	Disque	Arandela
6	2	2	2	2	2	2	2	Scheibe	washer	Disque	Arandela
7	4	4	4	4	4	4	4	Scheibe	washer	Disque	Arandela
8	2	2	2	2	2	2	2	Mutter	nut	Ècrou	Tuerca
9	2	2	2	2	2	2	2	Mutter	nut	Ècrou	Tuerca

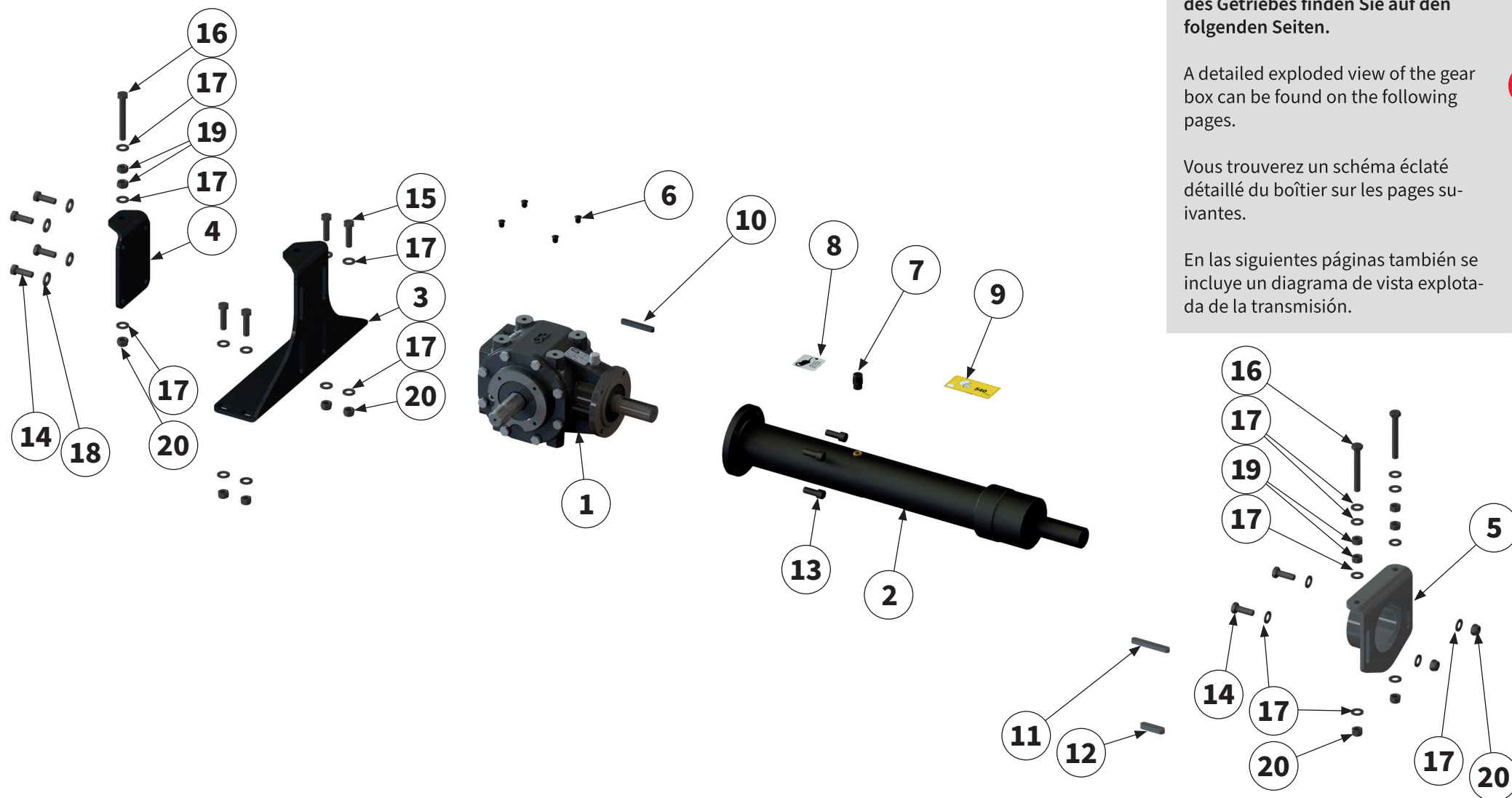

Eine detaillierte Explosionskizze des Getriebes finden Sie auf den folgenden Seiten.

A detailed exploded view of the gear box can be found on the following pages.

Vous trouverez un schéma éclaté détaillé du boîtier sur les pages suivantes.

En las siguientes páginas también se incluye un diagrama de vista explotada de la transmisión.

Pos.-Nr. No. Número Número	Ersatzteilnummer Manufacturer part number Numéro d'article du fabricant Número de pieza del fabricante							DE Bezeichnung	EN Designation	FR Désignation	ES Designación
	Anzahl quantity quantité número										
	MU-H 120	MU-H 140	MU-H 150	MU-H 160	MU-H 180	MU-H 200	MU-H 220				
1	MU980819-BRM							Getriebe	gear box	Système d'entraînement	Cambio
	1	1	1	1	1	1	1				
1a	00043960							Getriebe DF	gear box DF	Système d'entraînement DF	Cambio DF
	1	1	1	1	1	1	1				
2	00043969							Verlängerungs- welle 530	extension shaft 530	Arbre de rallonge 530	Eje de prolongación 530
	1	-	-	-	-	-	-				
		00043970						Verlängerungs- welle 615	extension shaft 615	Arbre de rallonge 615	Eje de prolongación 615
	-	1	1	-	-	-	-				
		00043978						Verlängerungs- welle 780	extension shaft 780	Arbre de rallonge 780	Eje de prolongación 780
-	-	-	1	1	1	1					
	00043979						Verlängerungs- welle 950	extension shaft 950	Arbre de rallonge 950	Eje de prolongación 950	
-	-	-	-	1	1	-					
	00043975						Verlängerungs- welle 1060	extension shaft 1060	Arbre de rallonge 1060	Eje de prolongación 1060	
-	-	-	-	-	-	1					
3	00006622							Getriebe- halter	gear box holder	Support de transmission	Soporte del cambio
	1	1	1	1	1	1	1				
4	00000922							Blech	sheet metal	Tôle	Chapa
	1	1	1	1	1	1	1				
5	00003597							Spannflansch	clamping flange	Flasque de serrage	Brida de su- jeción
	1	1	1	1	1	1	1				
6	00043075							Verschluss- stopfen	sealing plug	Bouchon de fermeture	Tapón de cierre
	4	4	4	4	4	4	4				
7	00043837							Entlüftungss- chraube	vent screw	Vis de purge d'air	Tornillo de pur- ga de aire
	1	1	1	1	1	1	1				
8	00044088							Aufkleber	label	" Autocollant"	Pegatina
	1	1	1	1	1	1	1				
9	00043889							Aufkleber	label	" Autocollant"	Pegatina
	1	1	1	1	1	1	1				

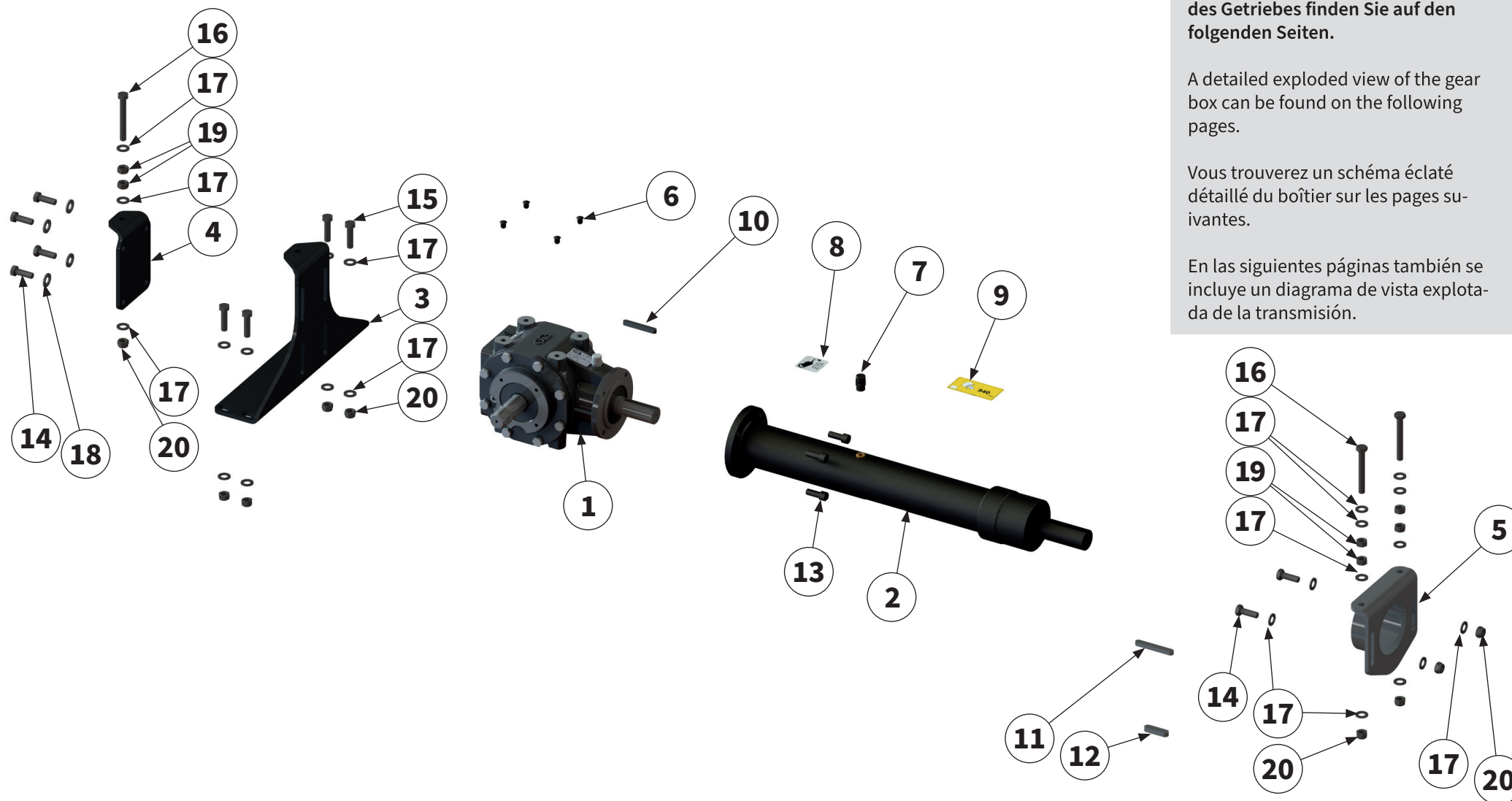

Eine detaillierte Explosionskizze des Getriebes finden Sie auf den folgenden Seiten.

A detailed exploded view of the gear box can be found on the following pages.

Vous trouverez un schéma éclaté détaillé du boîtier sur les pages suivantes.

En las siguientes páginas también se incluye un diagrama de vista explotada de la transmisión.



Pos.-Nr. No. Numéro Número	Ersatzteilnummer Manufacturer part number Numéro d'article du fabricant Número de pieza del fabricante							DE Bezeichnung	EN Designation	FR Désignation	ES Designación
	Anzahl quantity quantité número										
	MU-H 120	MU-H 140	MU-H 150	MU-H 160	MU-H 180	MU-H 200	MU-H 220				
10	1	1	1	00043208 1	1	1	1	Passfeder	parallel key	Clavette	Chaveta de ajuste
11	1	1	1	00043213 1	1	1	1	Passfeder	parallel key	Clavette	Chaveta de ajuste
12	1	1	1	00043215 1	1	1	1	Passfeder	parallel key	Clavette	Chaveta de ajuste
13	4	4	4	00043427 4	4	4	4	Schraube	bolt	Vis	Tornillo
14	6	6	6	00043621 6	6	6	6	Schraube	bolt	Vis	Tornillo
15	4	4	4	00043623 4	4	4	4	Schraube	bolt	Vis	Tornillo
16	3	3	3	00043632 3	3	3	3	Schraube	bolt	Vis	Tornillo
17	24	24	24	00043233 24	24	24	24	Scheibe	washer	Disque	Arandela
18	4	4	4	00043767 4	4	4	4	Scheibe	washer	Disque	Arandela
19	6	6	6	00043158 6	6	6	6	Mutter	nut	Ècrou	Tuerca
20	9	9	9	00043178 9	9	9	9	Mutter	nut	Ècrou	Tuerca



Getriebe-Eingangsdrehzahl | Input speed
 Vitesse d'entrée | Velocidad entrada | **540 U / min -1**



Getriebe-Eingangsdrehzahl | Input speed
 Vitesse d'entrée | Velocidad entrada | **750 U / min -1**



Getriebe-Eingangsdrehzahl | Input speed
 Vitesse d'entrée | Velocidad entrada | **1000 U / min -1**



8Pos.- Nr. No. Numéro Número	Ersatzteilnummer Manufacturer part number Numéro d'article du fabricant Número de pieza del fabricante							DE Bezeichnung	EN Designation	FR Désignation	ES Designación
	Anzahl quantity quantité número										
	MU-H 120	MU-H 140	MU-H 150	MU-H 160	MU-H 180	MU-H 200	MU-H 220				
1	00044026							Riemen- scheibe	belt pulley	Poulie	Polea
	1	1	1	1	1	1	1				
2	00044012							Riemen- scheibe	belt pulley	Poulie	Polea
	1	1	1	1	1	1	1				
3	00043998							Keilriemen	V-belt	Courroie trapézoïdale	Correa trapezoidal
	3	3	3	3	3	3	3				
4	00017143							Keilriemen	V-belt	Courroie trapézoïdale	Correa trapezoidal
	3	3	3	3	3	3	3				
5	00044050							Taperbuchse	bushing	Manchon	Cojinete
	1	1	1	1	1	1	1				
6	00044051							Taperbuchse	bushing	Manchon	Cojinete
	1	1	1	1	1	1	1				
6a							00044052	Taperbuchse	bushing	Manchon	Cojinete
	-	-	-	-	-	-	1				



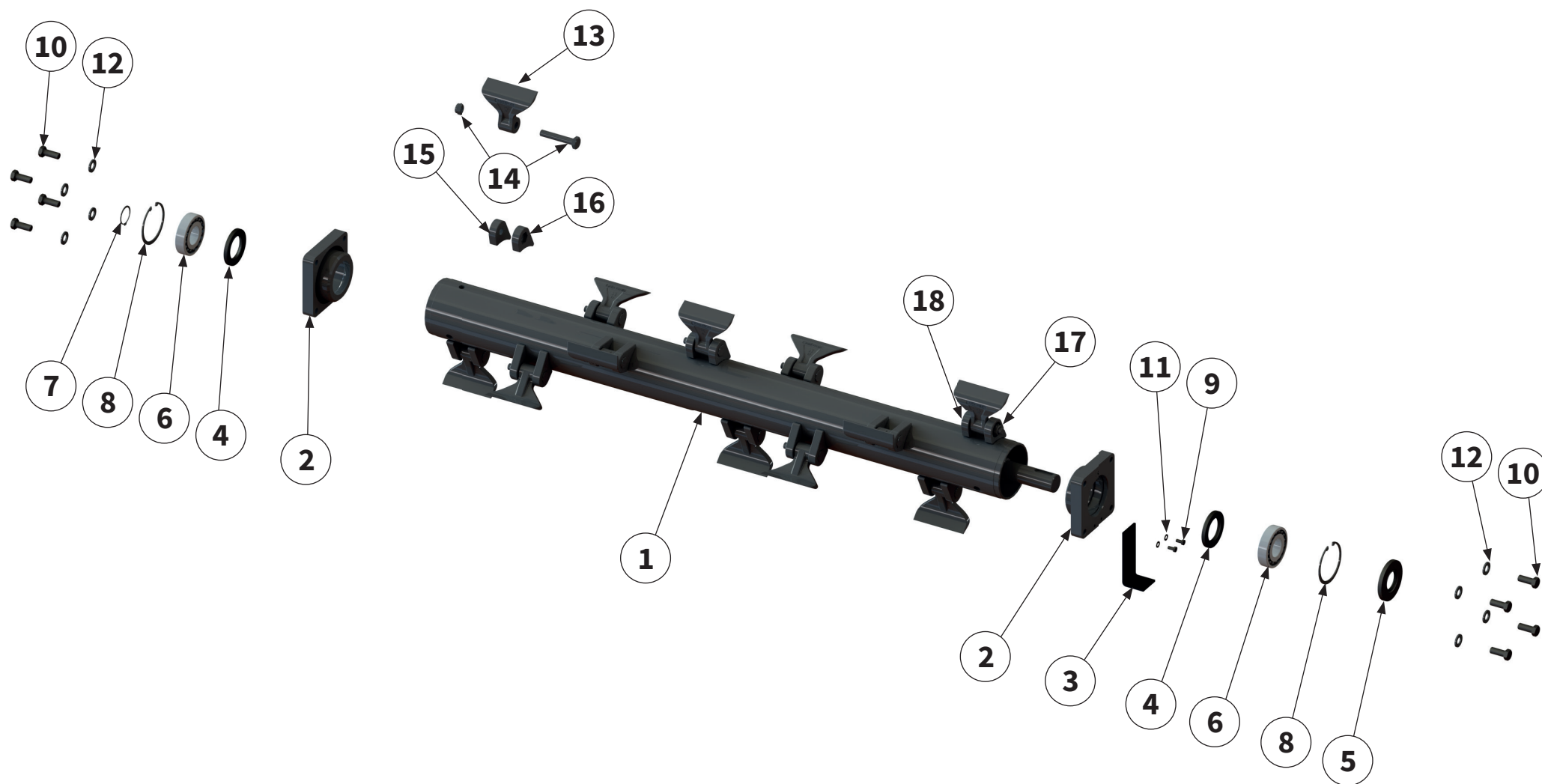

Pos.-Nr. No. Número Número	Ersatzteilnummer Manufacturer part number Numéro d'article du fabricant Número de pieza del fabricante							DE Bezeichnung	EN Designation	FR Désignation	ES Designación
	Anzahl quantity quantité número										
	MU-H 120	MU-H 140	MU-H 150	MU-H 160	MU-H 180	MU-H 200	MU-H 220				
1	00014498 1	00014485 1	00014479 1	00011707 1	00011708 1	00011709 1	00005412 1	Rotor inkl. Werkzeug	rotor with tools	Rotor avec outils	Rotor con herram
2	00045455						00003977 2	Rotorlager- schale	rotor bearing shell	Rotor coussinet	Cojinete del rotor
3	00045449						00018303 1	Verschlussblech	sealing plate	Tôle de fermeture	chapa de cierre
4	00039955						00043828 2	Wellen- dichtring	shaft seal	Bague à lèvres	Retén de eje
5	00043835						00043831 1	Wellen- dichtring	shaft seal	Bague à lèvres	Retén de eje
6	00044678						90980815 2	Wälzlager	roller bearing	Palier à roulement	Rodamiento
7	00043738						00043744 1	Sicherungsring	circlip	Bague de sécu- rité	Anillo de seguridad
8	00043752						00043753 2	Sicherungsring	circlip	Bague de sécu- rité	Anillo de seguridad
9	00043707						2	Schraube	bolt	Vis	Tornillo
10	00043651						00043720 8	Schraube	bolt	Vis	Tornillo
11	00043249						2	Scheibe	washer	Disque	Arandela
12	00043769						8	Scheibe	washer	Disque	Arandela
13	00001836						18	Hammer- schlegel	hammer flail	Marteaux « M »	Martillos
14	00018734						18	Schraube mit Mutter	bolt with nut	Vis avec écrou	Tornillo con tuerca

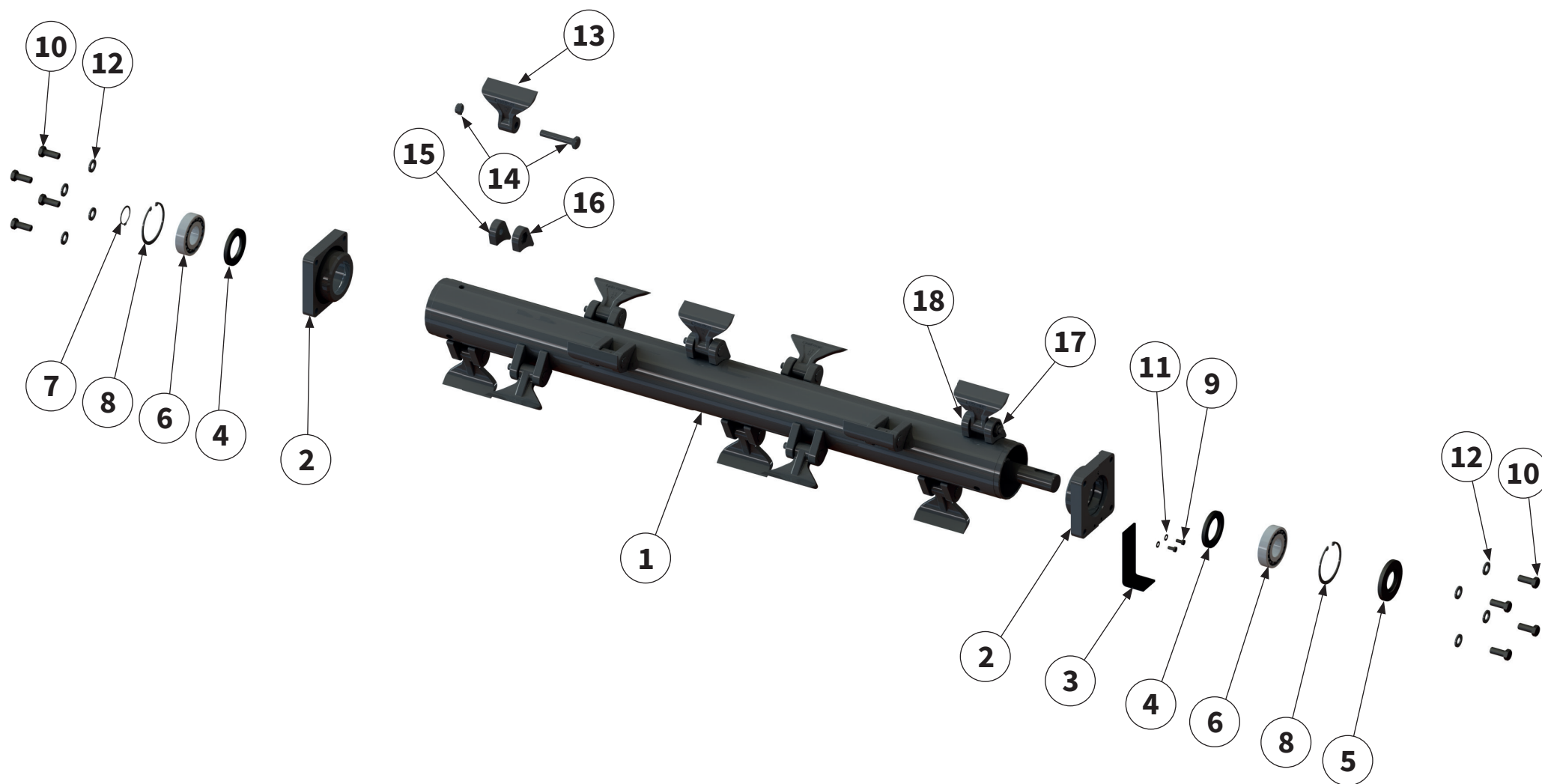

Pos.-Nr. No. Numéro Número	Ersatzteilnummer Manufacturer part number Numéro d'article du fabricant Número de pieza del fabricante							DE Bezeichnung	EN Designation	FR Désignation	ES Designación
	Anzahl quantity quantité número										
	MU-H 120	MU-H 140	MU-H 150	MU-H 160	MU-H 180	MU-H 200	MU-H 220				
15	00013633							Werkzeug- halter rund rechts	tool holders round right	Porte-outils rond à droite	Porta herra redondo derecha
	9	11	11	13	15	15	17				
16	00013632							Werkzeug- halter mit Sechskant links	tool holders with hexagon left	Porte-outils à six pans à gauche	Porta herramien- tas con hexago- nal izquierda
	9	11	11	13	15	15	17				
17	00019323							Werkzeug- halter rund links	tool holders round left	Porte-outils rond à gauche	Porta herramien- tas redondo izquierda
	1	1	1	1	1	1	1				
18	00019322							Werkzeug- halter mit Sechskant rechts	tool holders with hexagon right	Porte-outils à six pans à droite	Porta herramien- tas con hexago- nal derecha
	1	1	1	1	1	1	1				

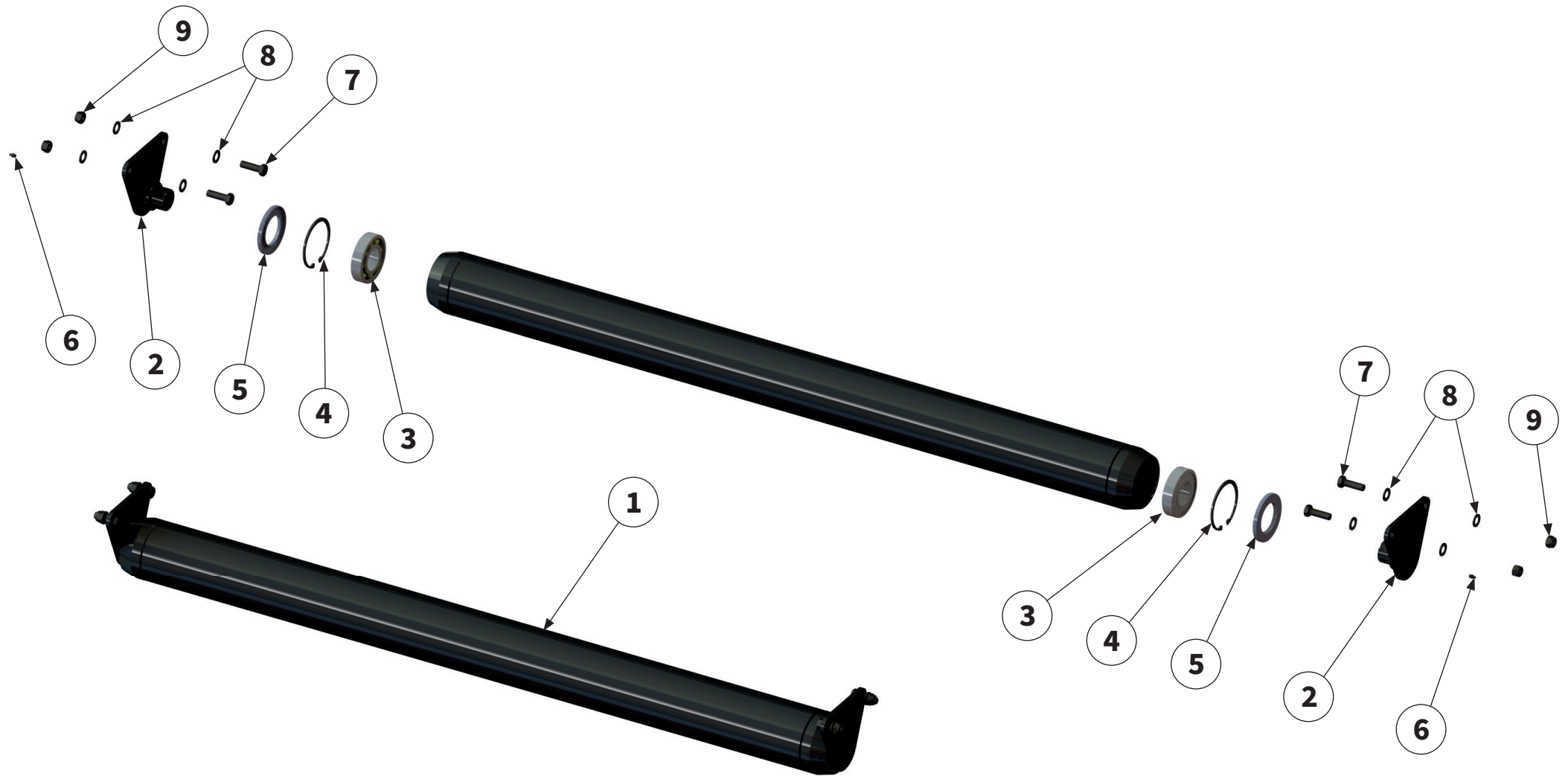

Pos.-Nr. No. Número Número	Ersatzteilnummer Manufacturer part number Número d' article du fabricant Número de pieza del fabricante							DE Bezeichnung	EN Designation	FR Désignation	ES Designación
	Anzahl quantity quantité número										
	MU-H 120	MU-H 140	MU-H 150	MU-H 160	MU-H 180	MU-H 200	MU-H 220				
1	00014500 1	00014487 1	00014481 1	00014464 1	00014460 1	00014456 1	00014490 1	Stützwalze	support roller	Rouleau d'appui	Cilindro de apoyo
2	00001547							Halteplatte	retainer plate	Plaque de support	Placa de retención
3	00044677							Wälzlager	roller bearing	Palier à roulement	Rodamiento
4	00043753							Sicherungsring	circlip	Bague de sécurité	Anillo de seguridad
5	00043832							Wellendichtring	shaft sealing ring	Bague à lèvres	Retén de eje
6	00043301							Schmiernippel	lubricating nipple	Nipple de graissage	Engrasador
7	00043653							Schraube	bolt	Vis	Tornillo
8	00043235							Scheibe	washer	Disque	Arandela
9	00043180							Mutter	nut	Écrou	Tuerca

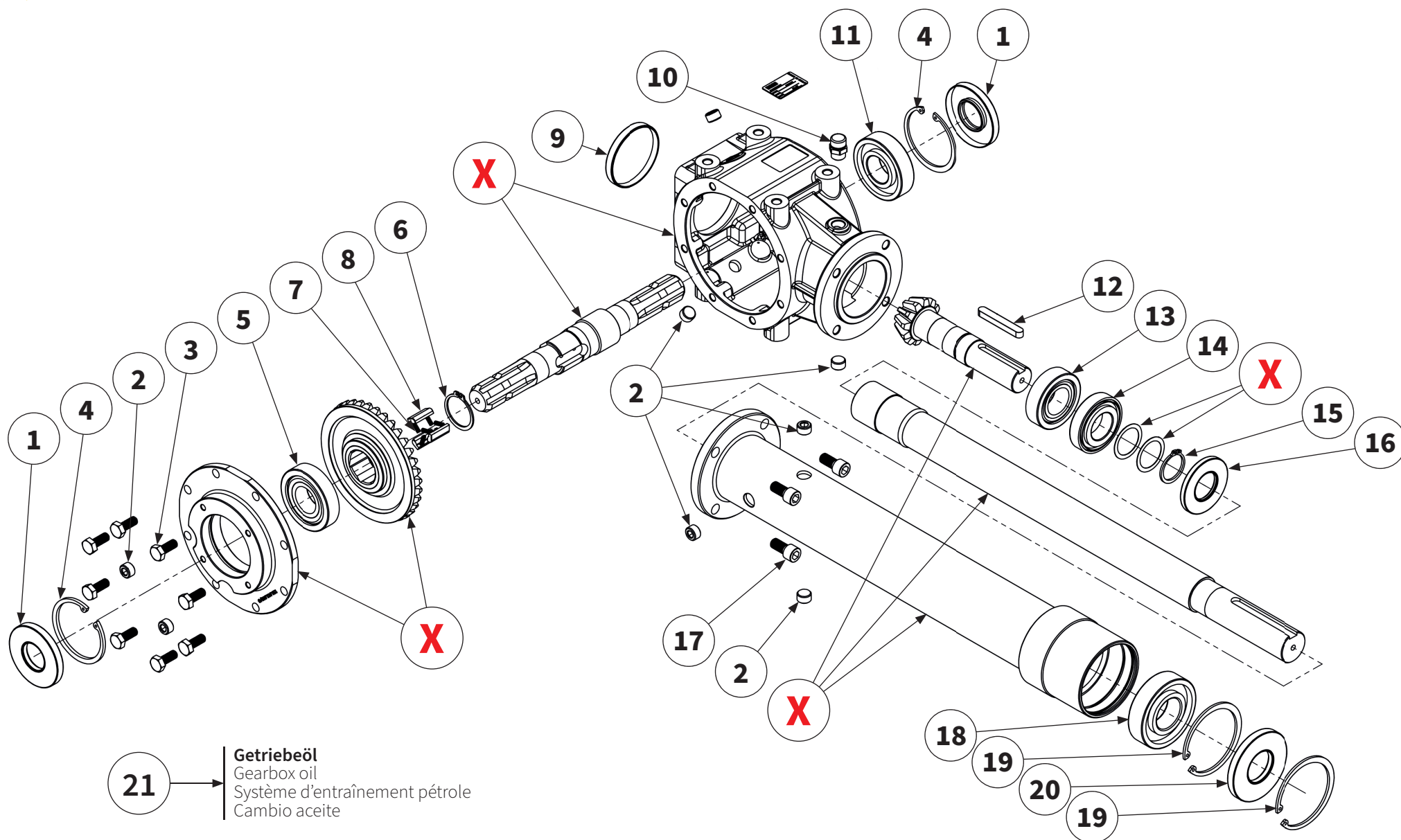

21 → **Getriebeöl**
 Gearbox oil
 Système d'entraînement pétrole
 Cambio aceite

Pos.-Nr. No. Número Número	Ersatzteilnummer Manufacturer part number Numéro d'article du fabricant Número de pieza del fabricante							DE Bezeichnung	EN Designation	FR Désignation	ES designación
	Anzahl quantity quantité número										
	MU-H 120	MU-H 140	MU-H 150	MU-H 160	MU-H 180	MU-H 200	MU-H 220				
1	00043804							Wellendichtring	shaft seal	Baque d'levre	Retén de eye
	2	2	2	2	2	2	2				
2	90623017							Ablasskontrollschraube	bolt	Vis	Tornillo
	5	5	5	5	5	5	5				
3	00043601							Schraube	bolt	Vis	Tornillo
	8	8	8	8	8	8	8				
4	00043763							Sicherungsring	circlip	Bague de sécurité	Anillo de seguridad
	2	2	2	2	2	2	2				
5	90623011							Lager	bearing	Palier	Cojinete
	1	1	1	1	1	1	1				
6	00043738							Sicherungsring	circlip	Bague de sécurité	Anillo de seguridad
	1	1	1	1	1	1	1				
7	90623021							Spiralfeder	spiral spring	Ressort spiral	Resorte espiral
	6	6	6	6	6	6	6				
8	90623008							Sperrklinke Freilauf	detent freewheel	Cliquet d'arrêt roue libre	Trinquete de bloqueo rueda libre
	3	3	3	3	3	3	3				
9	90623004							Verschlussdeckel	cap	Couvercie de fermeture	Tapa de cierre
	1	1	1	1	1	1	1				
10	00043837							Getriebeentlüftung	gearbox breather	Boîte de vitesses reniflard	Respiradero de la caja de cambios
	1	1	1	1	1	1	1				
11	90490023							Lager	bearing	Palier	Cojinete
	1	1	1	1	1	1	1				
X	Teile einzeln vom Hersteller nicht lieferbar Parts from the manufacturer cannot be supplied individually Pièces non livrables séparément par le fabricant El fabricante no suministra piezas individuales										

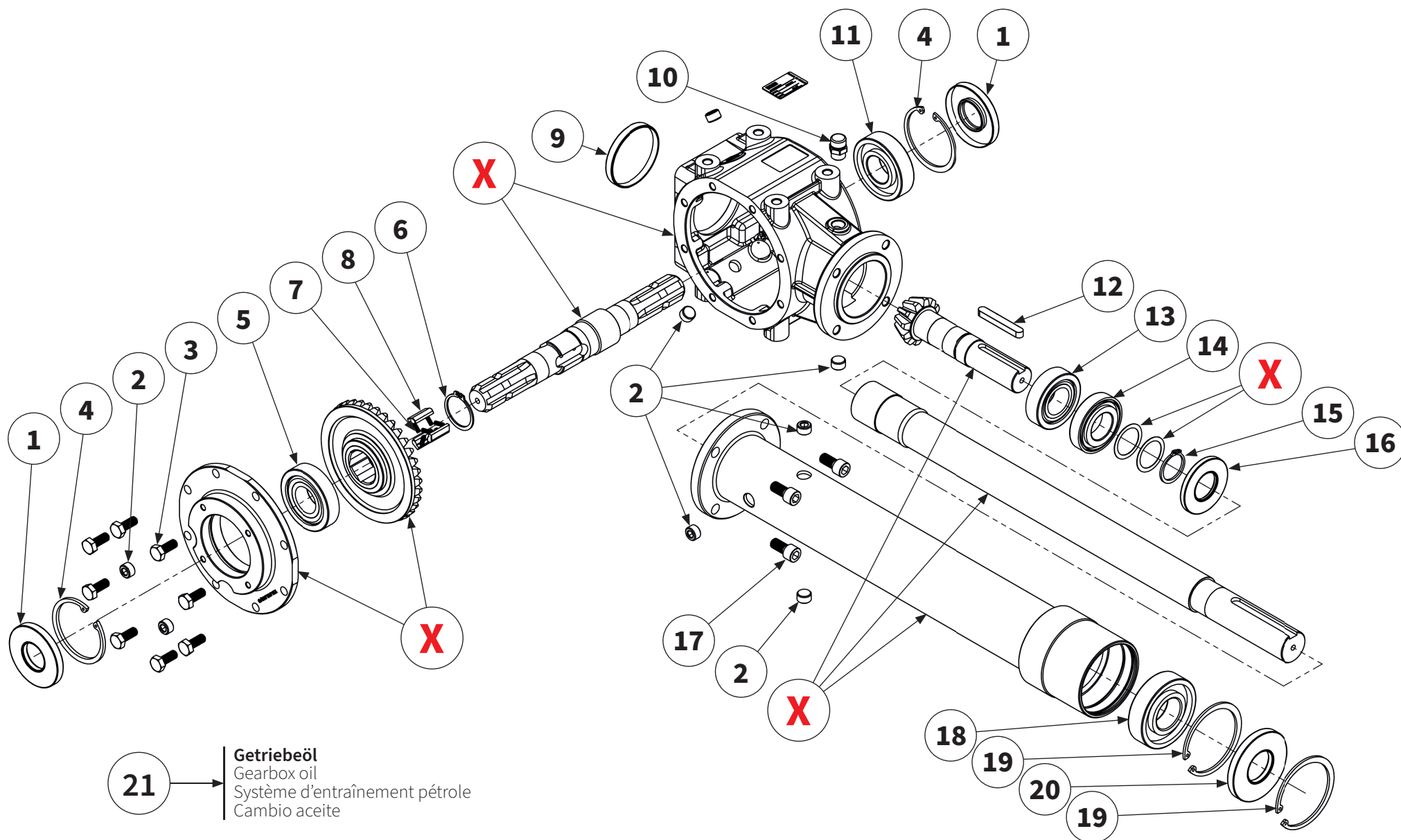

Pos.-Nr. No. Número Número	Ersatzteilnummer Manufacturer part number Número d' article du fabricant Número de pieza del fabricante							DE Bezeichnung	EN Designation	FR Désignation	ES Designación
	Anzahl quantity quantité número										
	MU-H 120	MU-H 140	MU-H 150	MU-H 160	MU-H 180	MU-H 200	MU-H 220				
12	00043208							Passfeder	parallel key	Clavette	Chaveta de ajuste
	1	1	1	1	1	1	1				
13	90490008							Lager	bearing	Palier	Cojinete
	1	1	1	1	1	1	1				
14	90310005							Lager	bearing	Palier	Cojinete
	1	1	1	1	1	1	1				
15	00043734							Sicherungsring	circlip	Bague de sécurité	Anillo de seguridad
	2	2	2	2	2	2	2				
16	00043803							Wellendichtring	shaft seal	Baque d' levre	Retén de eye
	1	1	1	1	1	1	1				
17	00043427							Schraube	bolt	Vis	Tornillo
	4	4	4	4	4	4	4				
18	90490018							Lager	bearing	Palier	Cojinete
	1	1	1	1	1	1	1				
19	00043764							Sicherungsring	circlip	Bague de sécurité	Anillo de seguridad
	1	1	1	1	1	1	1				
20	00043809							Wellendichtring	shaft seal	Baque d' levre	Retén de eye
	1	1	1	1	1	1	1				
21	40008825 (1l)							Getriebeöl	gearbox oil	Boîtier pétrole	Cambio aceite
	2	2	2	2	2	2	2				
21a	1,8 l	1,85 l	1,85 l	2 l	2 l	2 l	2 l	Füllmenge inkl. Verlängerungswelle	Oil fill quantity included extension shaft	Quantité d'huile incluse Arbre de rallonge	Cantidad de llenado de aceite inclusive Eje de prolongación
X	Teile einzeln vom Hersteller nicht lieferbar Parts from the manufacturer cannot be supplied individually Pièces non livrables séparément par le fabricant El fabricante no suministra piezas individuales										

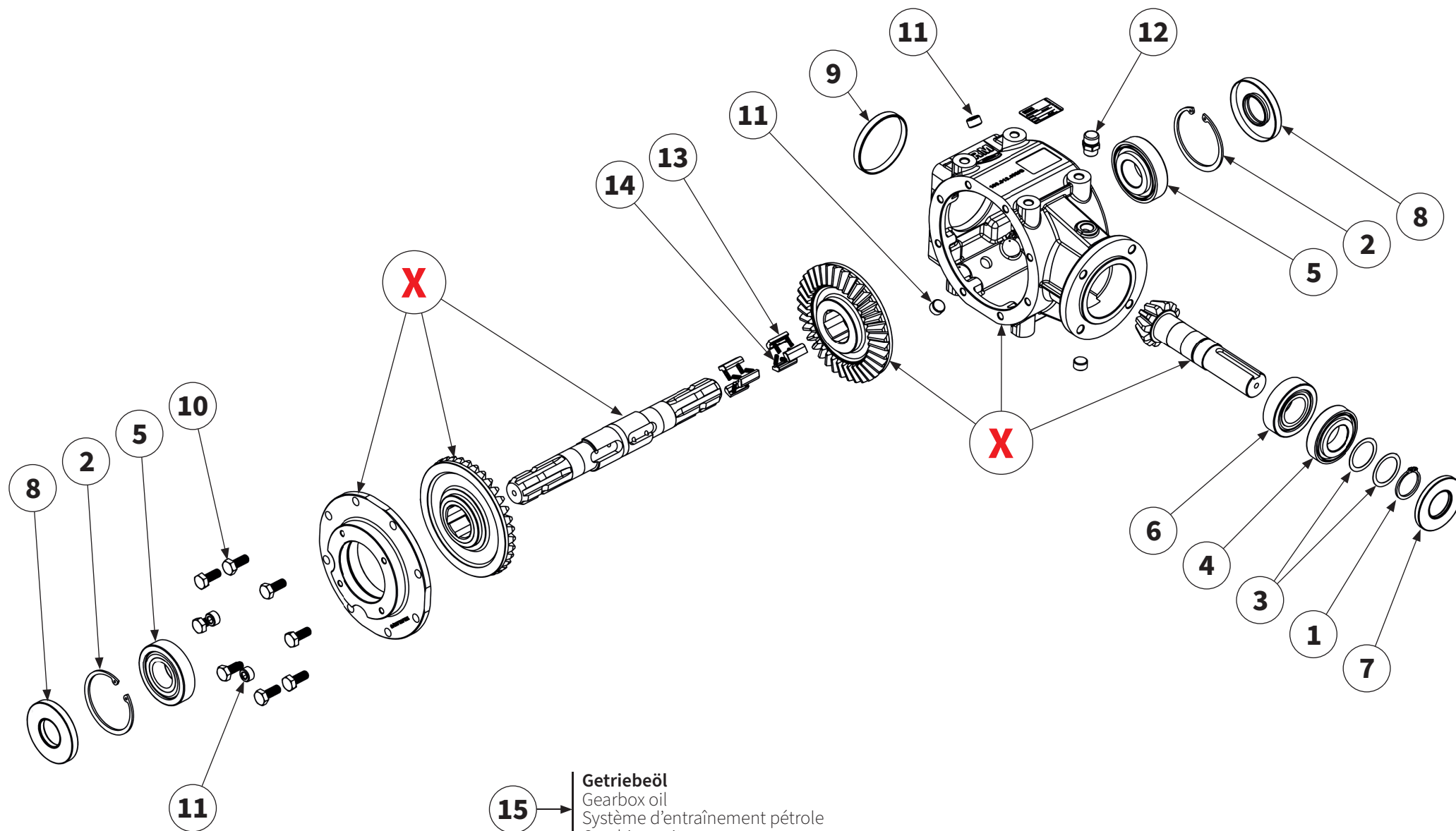

15 → **Getriebeöl**
 Gearbox oil
 Système d'entraînement pétrole
 Cambio aceite

Pos.-Nr. No. Número Número	Ersatzteilnummer Manufacturer part number Numéro d'article du fabricant Número de pieza del fabricante							DE Bezeichnung	EN Designation	FR Désignation	ES designación
	Anzahl quantity quantité número										
	MU-H 120	MU-H 140	MU-H 150	MU-H 160	MU-H 180	MU-H 200	MU-H 220				
1	1	1	1	1	1	1	1	Sicherungsring	circlip	Bague de sécurité	Anillo de seguridad
2	2	2	2	2	2	2	2	Sicherungsring	circlip	Bague de sécurité	Anillo de seguridad
3	2	2	2	2	2	2	2	Passscheibe	shim	Rondelle d'ajustage	Arandela de ajuste
4	1	1	1	1	1	1	1	Lager	bearing	Palier	Cojinete
5	2	2	2	2	2	2	2	Lager	bearing	Palier	Cojinete
6	1	1	1	1	1	1	1	Lager	bearing	Palier	Cojinete
7	1	1	1	1	1	1	1	Wellendichtring	shaft seal	Bague d'levre	Retén de eye
8	2	2	2	2	2	2	2	Wellendichtring	shaft seal	Bague d'levre	Retén de eye
9	1	1	1	1	1	1	1	Verschlussdeckel	cap	Couvercie de fermeture	Tapa de cierre
10	8	8	8	8	8	8	8	Schraube	bolt	Vis	Tornillo
11	5	5	5	5	5	5	5	Ablasskontrollschraube	bolt	Vis	Tornillo
12	1	1	1	1	1	1	1	Getriebeentlüftung	gearbox breather	Boîte de vitesses reniflard	Respiradero de la caja de cambios
13	6	6	6	6	6	6	6	Sperrklinke Freilauf	detent freewheel	Cliquet d'arrêt roue libre	Trinquete de bloqueo rueda libre
14	12	12	12	12	12	12	12	Spiralfeder	spiral spring	Ressort spiral	Resorte espiral
15	2	2	2	2	2	2	2	Getriebeöl	gearbox oil	Boîtier pétrole	Cambio aceite
X	Teile einzeln vom Hersteller nicht lieferbar Parts from the manufacturer cannot be supplied individually Pièces non livrables séparément par le fabricant El fabricante no suministra piezas individuales										

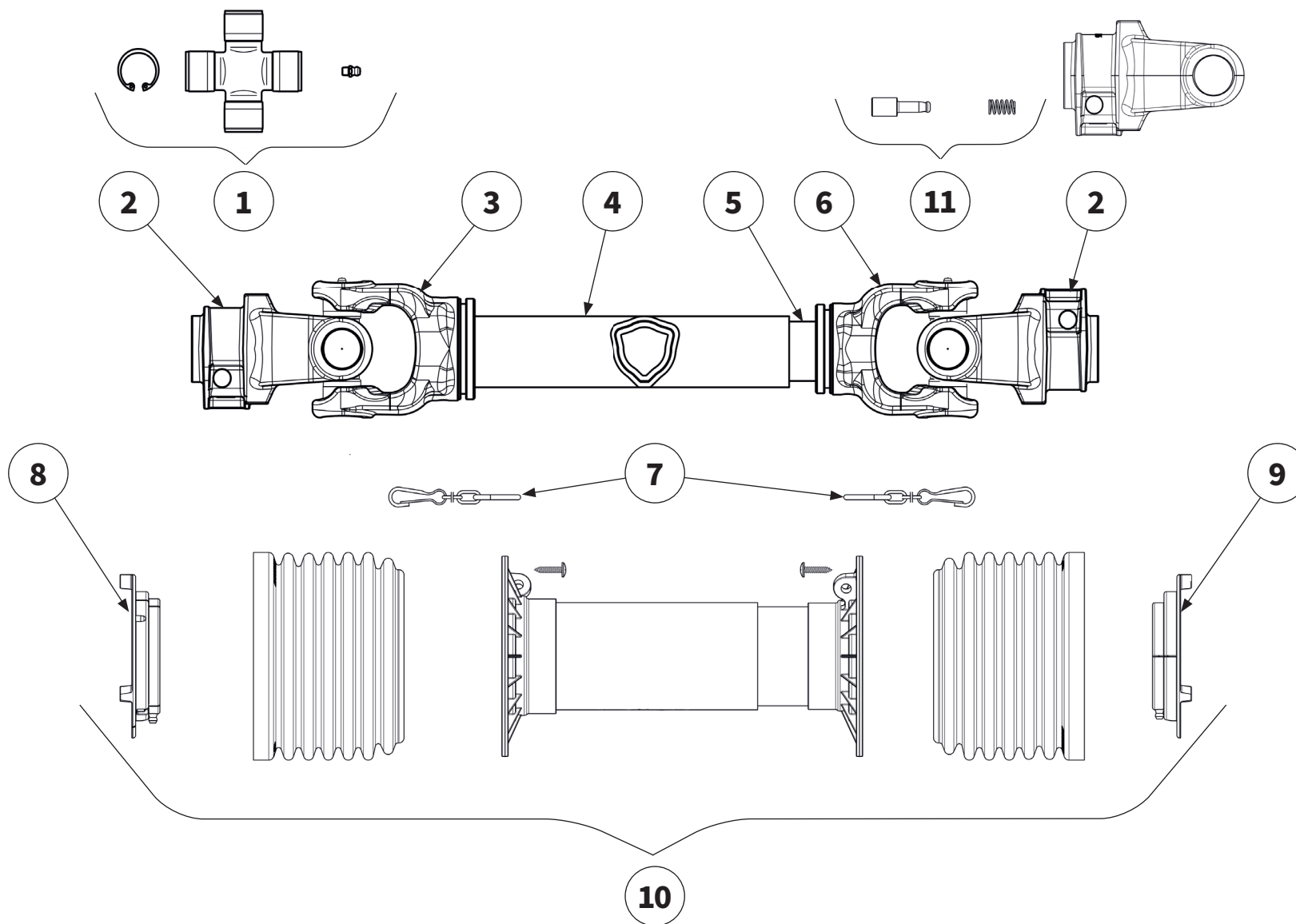

Pos.-Nr. No. Número Número	Ersatzteilnummer Manufacturer part number Numéro d'article du fabricant Número de pieza del fabricante							DE Bezeichnung	EN Designation	FR Désignation	ES Designación
	Anzahl quantity quantité número										
	MU-H 120	MU-H 140	MU-H 150	MU-H 160	MU-H 180	MU-H 200	MU-H 220				
1	40024115							Kreuzgarnitur	Cross Kit	Croisillon	Crucetas
	2	2	2	2	2	2	2				
2	40039376							Außengabel	Outer Yoke	Mâchoire	Horquillas
	2	2	2	2	2	2	2				
3	40045404							Innengabel für Außenrohr	Outer Yoke Teleskop-Tube	Mâchoire pour tube extérieur	Horquillas para tubo exterior
	1	1	1	1	1	1	1				
4	40013120							Profil-Außenrohr	Outer Telescope Tube	Tube externe	Tubo exterior
	1	1	1	1	1	1	1				
5	40011735							Profil-Innenrohr	Inner Telescope Tube	Tube interne	Tubo interior
	1	1	1	1	1	1	1				
6	40054148							Innengabel für Innenrohr	Inner Yoke for Telescope Tube	Mâchoire pour tube intérieur	Horquillas para tubo interior
	1	1	1	1	1	1	1				
7	40042477							Haltekette	chain	Chaîne de retenue	Cadenas de seguridad
	2	2	2	2	2	2	2				
8	40040260							Lauftring	Raceway	Palier de glissement	Anillo soporte
	1	1	1	1	1	1	1				
9	40032605							Lauftring	Raceway	Palier de glissement	Anillo soporte
	1	1	1	1	1	1	1				
10	40011347							Gelenkwellenschutz	Safety Shield complete	Protection contre les accidents	Protecciones de seguridad
	1	1	1	1	1	1	1				
11	40045908							Schiebestift	Push Pin Kit	Veru rapide	Pulsador
	2	2	2	2	2	2	2				



Pos.-Nr. No. Numéro Número	Ersatzteilnummer Manufacturer part number Numéro d'article du fabricant Número de pieza del fabricante							DE Bezeichnung	EN Designation	FR Désignation	ES Designación	
	Anzahl quantity quantité número											
	MU-H 120	MU-H 140	MU-H 150	MU-H 160	MU-H 180	MU-H 200	MU-H 220					
1	1	1	1	00014416 1	1	1	1	1	Abstellstütze	supporting leg	Béquille de stationnement	Pie de apoyo
2	2	2	2	00014417 2	2	2	2	2	Halter	holder	Support	Soporte
3	1	1	1	00001247 1	1	1	1	1	Bolzen	pin	Axe	Perno
4	3	3	3	00043624 3	3	3	3	3	Schraube	bolt	Vis	Tornillo
5	6	6	6	00043233 6	6	6	6	6	Scheibe	washer	Disque	Arandela
6	3	3	3	00043178 3	3	3	3	3	Mutter	nut	Écrou	Tuerca

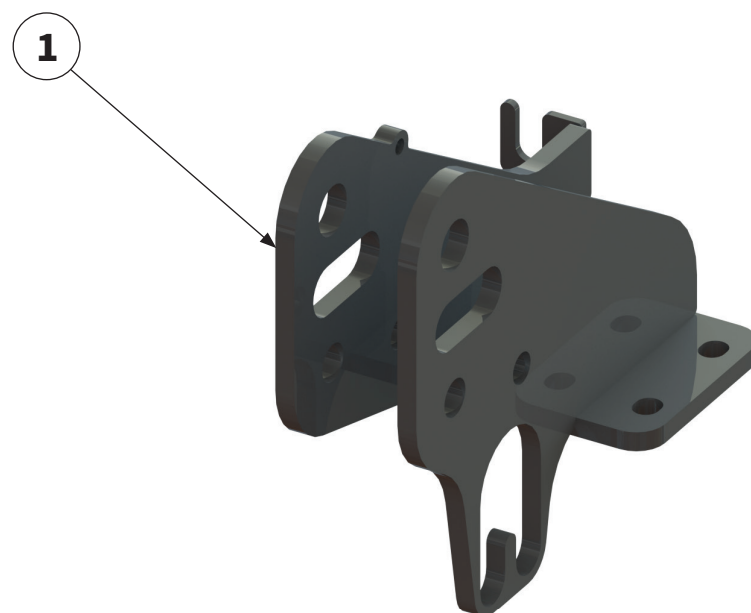

Pos.-Nr. No. Numéro Número	Ersatzteilnummer manufacturer part number Numéro d'article du fabricant Número de pieza del fabricante							DE Bezeichnung	EN Designation	FR Désignation	ES Designación
	Anzahl quantity quantité número										
	MU-H 120	MU-H 140	MU-H 150	MU-H 160	MU-H 180	MU-H 200	MU-H 220				
1	-	1	1	1	1	1	1	Oberlenkeraufnahme	upper link receiver	Logement du bras supérieur	Alojamiento del brazo superior



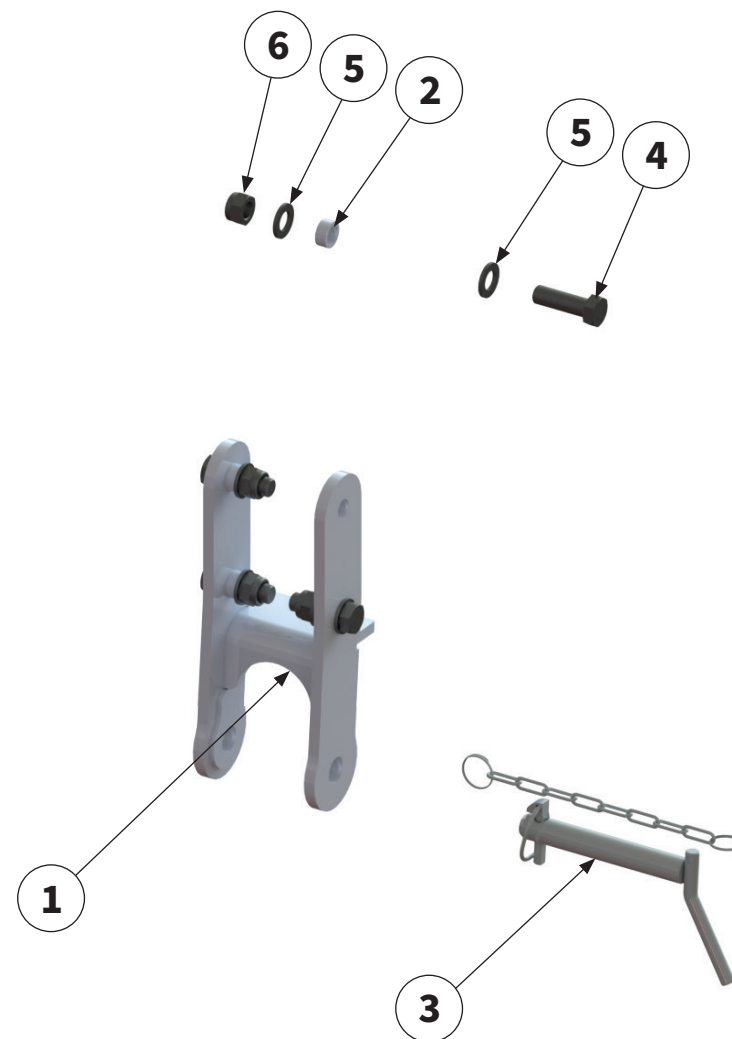
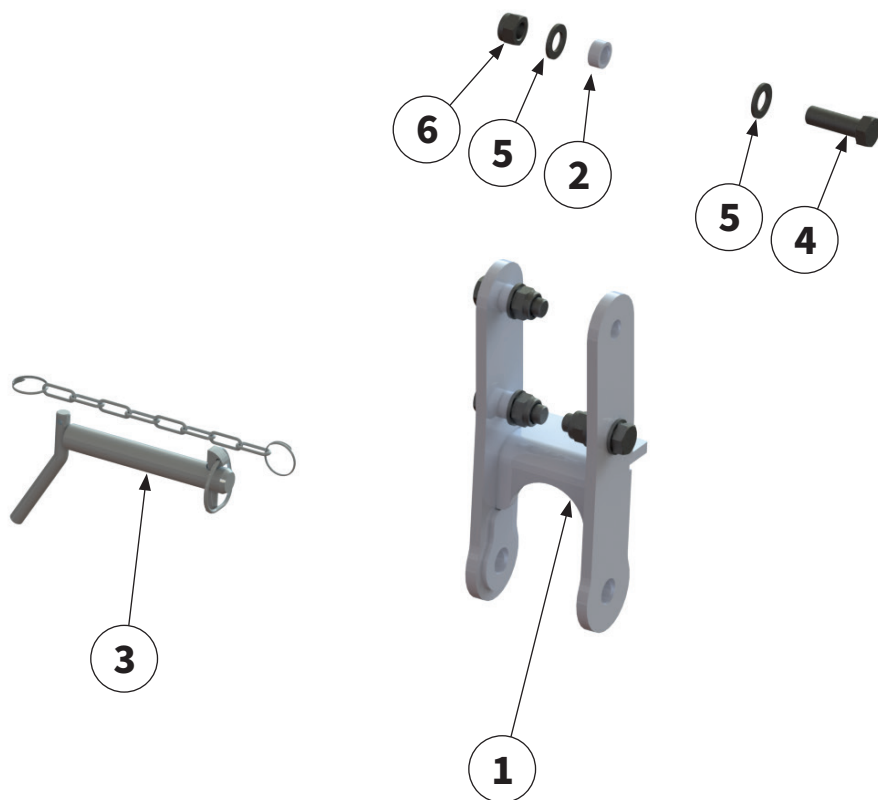

Pos.-Nr. No. Numéro Número	Ersatzteilnummer manufacturer part number Numéro d'article du fabricant Número de pieza del fabricante							DE Bezeichnung	EN Designation	FR Désignation	ES Designación
	Anzahl quantity quantité número										
	MU-H 120	MU-H 140	MU-H 150	MU-H 160	MU-H 180	MU-H 200	MU-H 220				
1	-	2	2	2	2	2	2	Verlängerung Unterlenker Kat.1	extension lower link	Rallonge du bras inférieur	Prolongación de la brazo inferior
2	-	8	8	8	8	8	8	Distanzhülse	spacer	Disque d'écartement	Arandela distanciador
3	-	2	2	2	2	2	2	Bolzen mit Kette	pin with chain	Boulon à chaîne	Perno con ca- dena
4	-	8	8	8	8	8	8	Schraube	bolt	Vis	Tornillo
5	-	16	16	16	16	16	16	Scheibe	washer	Disque	Arandela
6	-	8	8	8	8	8	8	Mutter	nut	Ècrou	Tuerca



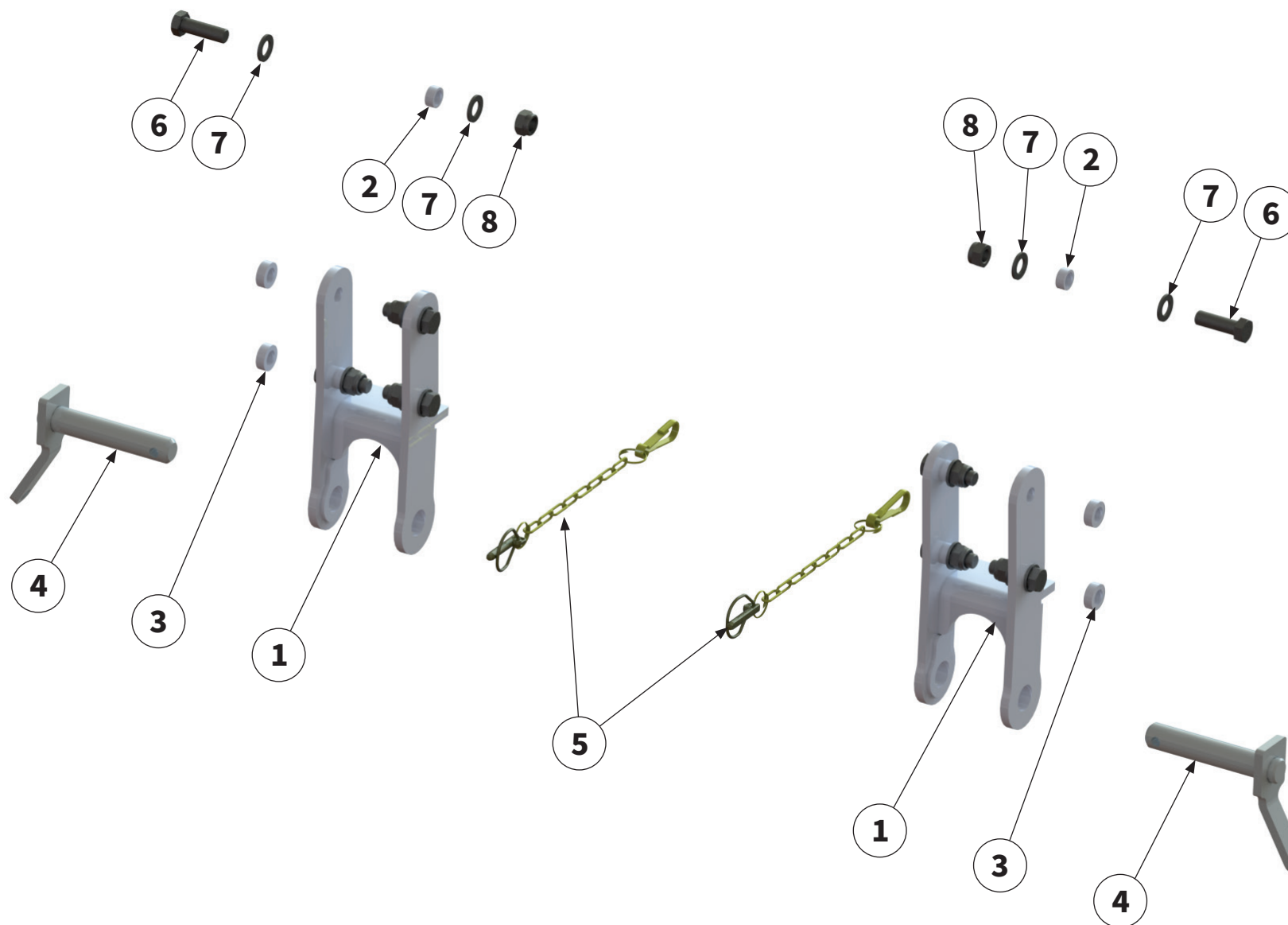

Pos.-Nr. No. Numéro Número	Ersatzteilnummer manufacturer part number Numéro d'article du fabricant Número de pieza del fabricante							DE Bezeichnung	EN Designation	FR Désignation	ES Designación
	Anzahl quantity quantité número										
	MU-H 120	MU-H 140	MU-H 150	MU-H 160	MU-H 180	MU-H 200	MU-H 220				
1	-	2	2	2	2	2	2	Verlängerung Unterlenker Kat.2	extension lower link	Rallonge du bras inférieur	Prolongación de la brazo inferior
2	-	8	8	8	8	8	8	Distanzhülse	spacer	Disque d'écartement	Arandela distanciador
3	-	4	4	4	4	4	4	Distanzhülse	spacer	Disque d'écartement	Arandela distanciador
4	-	2	2	2	2	2	2	Bolzen mit Kette	pin with chain	Boulon à chaîne	Perno con ca- dena
5	-	2	2	2	2	2	2	Sicherungs- element	locking element	Élément de sécurité	Elemento de seguridad
6	-	8	8	8	8	8	8	Schraube	bolt	Vis	Tornillo
7	-	16	16	16	16	16	16	Scheibe	washer	Disque	Arandela
8	-	8	8	8	8	8	8	Mutter	nut	Ècrou	Tuerca

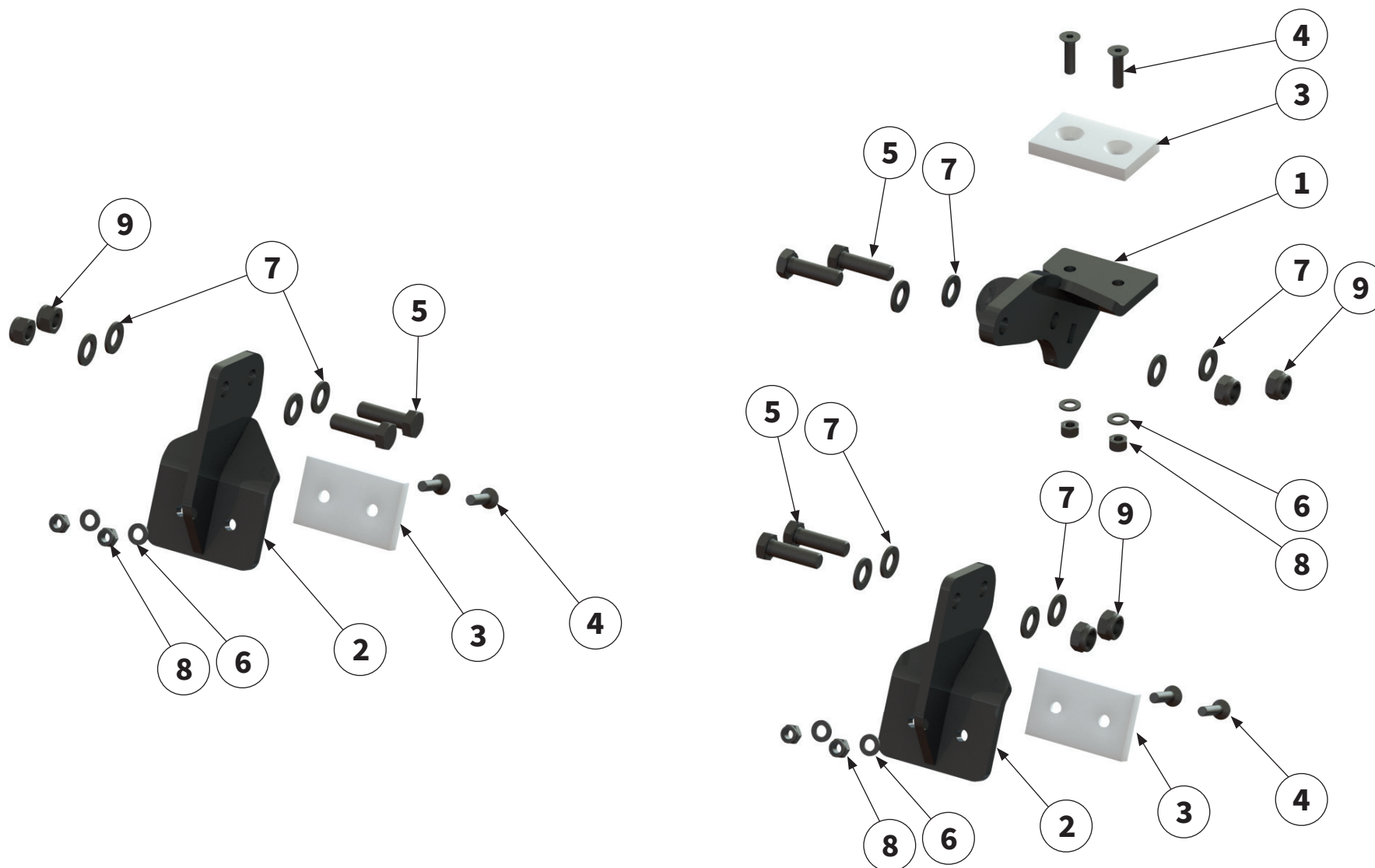

Pos.-Nr. No. Número Número	Ersatzteilnummer Manufacturer part number Numéro d'article du fabricant Número de pieza del fabricante							DE Bezeichnung	EN Designation	FR Désignation	ES Designación
	Anzahl quantity quantité número										
	MU-H 120	MU-H 140	MU-H 150	MU-H 160	MU-H 180	MU-H 200	MU-H 220				
1	-	1	1	1	1	1	1	Entlastungs- element	Relief element	Élément de secours	Elemento de relieve
2	-	2	2	2	2	2	2	Entlastungs- element	Relief element	Élément de secours	Elemento de relieve
3	-	3	3	3	3	3	3	Gleitplatte	slide plate	Plaque de glissement	Placa deslizante
4	-	6	6	6	6	6	6	Schraube	bolt	Vis	Tornillo
7	-	6	6	6	6	6	6	Schraube	bolt	Vis	Tornillo
5	-	6	6	6	6	6	6	Scheibe	washer	Disque	Arandela
8	-	12	12	12	12	12	12	Scheibe	washer	Disque	Arandela
6	-	6	6	6	6	6	6	Mutter	nut	Écrou	Tuerca
9	-	6	6	6	6	6	6	Mutter	nut	Écrou	Tuerca

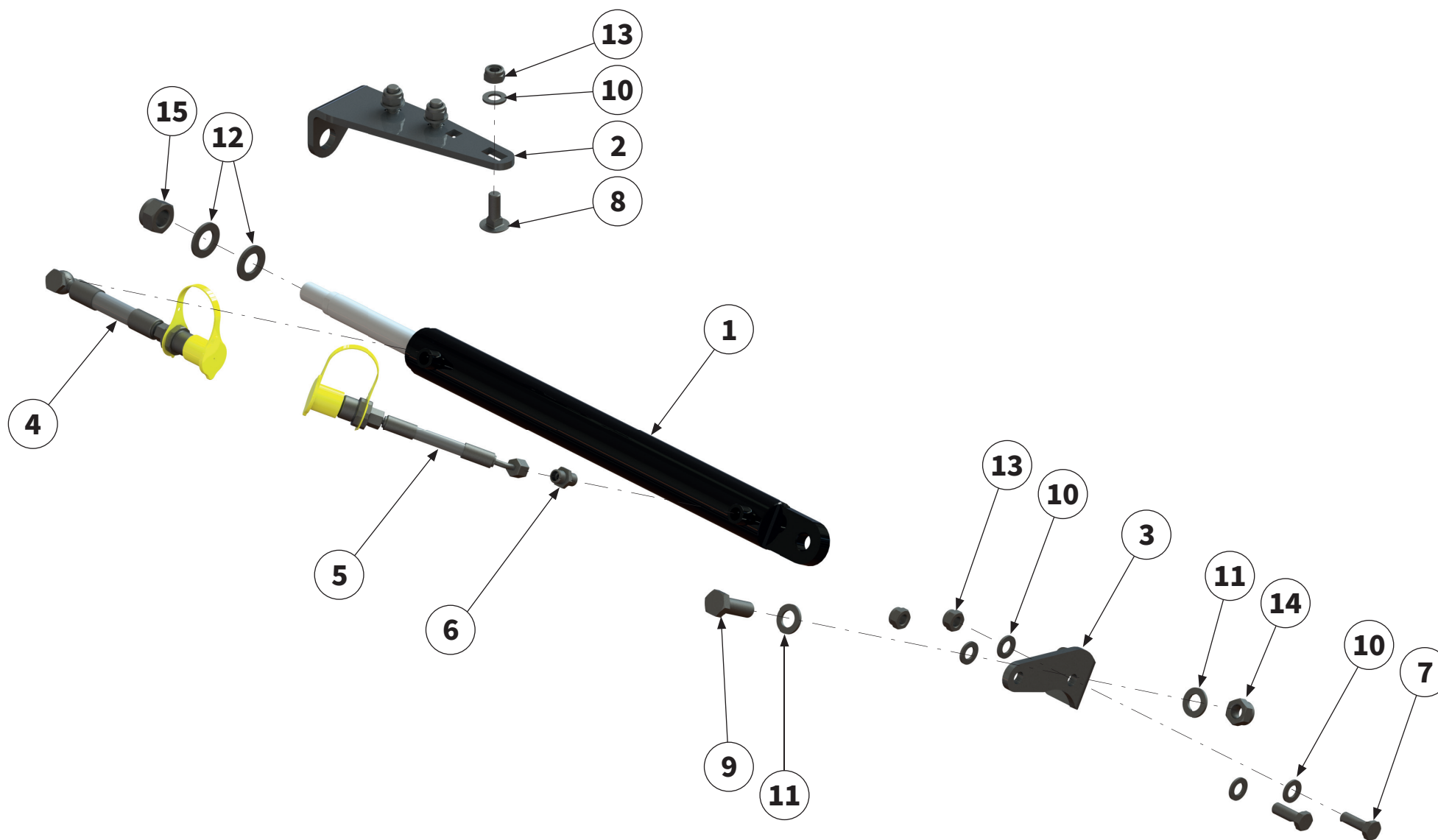

Pos.-Nr. No. Número Número	Ersatzteilnummer Manufacturer part number Numéro d'article du fabricant Número de pieza del fabricante							DE Bezeichnung	EN Designation	FR Désignation	ES Designación	
	Anzahl quantity quantité número											
	MU-H 120	MU-H 140	MU-H 150	MU-H 160	MU-H 180	MU-H 200	MU-H 220					
1	-	00014475		00045914				Hydraulik- zylinder	hydraulic cylinder	Vérin hydraulique	Cilindro hidráulico	
		1	1	1	1	1	1					
1a	-	90260003		90260004				Dichtsatz	packet seal	Kit d'étancheté	Juego de estanqueización	
		1	1	1	1	1	1					
2	-	00014439							Zylinderauf- nahme	cylinder bracket	Porte-cylindre	Porta cilindro
		1	1	1	1	1	1					
3	-	00014438							Aufnahme	holder	Support	Alojamiento
		1	1	1	1	1	1					
4	-	00046059							Hydraulik- schlauch	hydraulic hose	Tuyau hydraulique	Tubo flexible hidráulico
		1	1	1	1	1	1					
5	-	00046058							Hydraulik- schlauch	hydraulic hose	Tuyau hydraulique	Tubo flexible hidráulico
		1	1	1	1	1	1					
6	-	40050088							Verschraubung	threaded connection	Raccord à vis	Unión atornillada
		1	1	1	1	1	1					
7	-	00043621							Schraube	bolt	Vis	Tornillo
		2	2	2	2	2	2					
8	-	00043333							Schraube	bolt	Vis	Tornillo
		3	3	3	3	3	3					
9	-	00043720							Schraube	bolt	Vis	Tornillo
		1	1	1	1	1	1					
10	-	00043233							Scheibe	washer	Disque	Arandela
		7	7	7	7	7	7					
11	-	00043235							Scheibe	washer	Disque	Arandela
		2	2	2	2	2	2					
12	-	00043237							Scheibe	washer	Disque	Arandela
		2	2	2	2	2	2					
13	-	00043178							Mutter	nut	Écrou	Tuerca
		5	5	5	5	5	5					
14	-	00043180							Mutter	nut	Écrou	Tuerca
		1	1	1	1	1	1					
15	-	00043184							Mutter	nut	Écrou	Tuerca
		1	1	1	1	1	1					

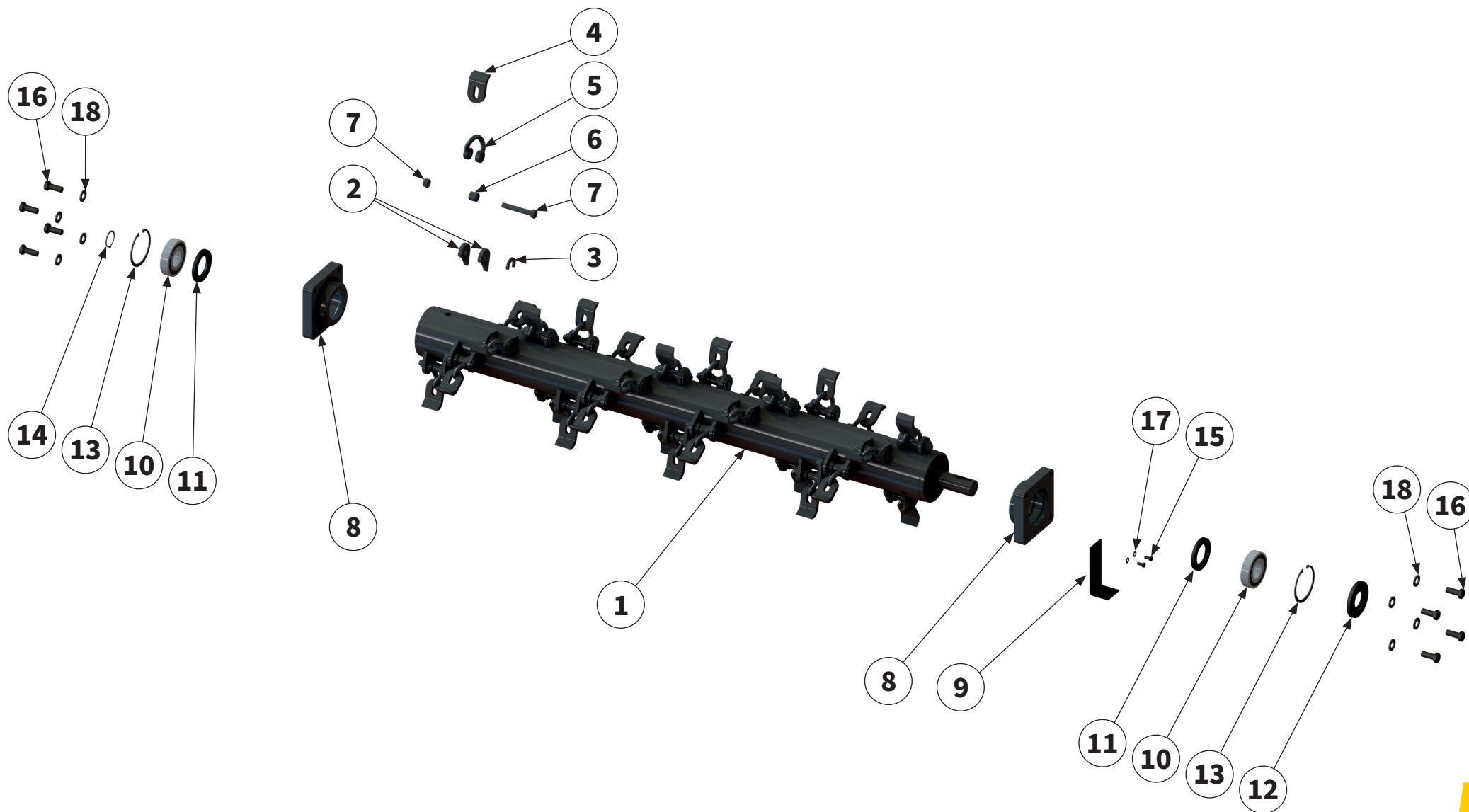

Pos.-Nr. No. Número	Ersatzteilnummer Manufacturer part number Numéro d'article du fabricant Número de pieza del fabricante							DE Bezeichnung	EN Designation	FR Désignation	ES Designación			
	Anzahl quantity quantité número													
	MU-H 120	MU-H 140	MU-H 150	MU-H 160	MU-H 180	MU-H 200	MU-H 220							
1	00042022 1	00042013 1	00042004 1	00041998 1	00041992 1	00041966 1	00035031 1	Schäkelrotor inkl. Werkzeug	rotor with tools	Rotor avec outils	Rotor con herram			
2	48	56	60	00019099 64			72	80	92	Werkzeug- halter	tool holders	Porte-outils	Portaherramien- tas	
3	24	28	30	00019100 32			36	40	46	Verdreh- sicherung	anti-twist protection	Sécurité anti-torsion	Seguro contra giro	
4	24	28	30	00001431 32			36	40	46	Schäkel- messer	shackle flail	Lame de manille	Chuchilla del grillete	
5	24	28	30	00001429 32			36	40	46	Schäkel	shackle	Manille	Grillete	
6	24	28	30	00001428 32			36	40	46	Buchse	bushing	Manchon	Cojinete	
7	24	28	30	00044847 32			36	40	46	Schraube mit Mutter	bolt with nut	Vis avec Écrou	Tornillo con Tuerca	
8	2	2	2	00045455 2			2	2	2	00003977 2	Rotor- lagerschale	rotor holder	Support de Rotor	Soporte del Rotor
9	1	1	1	00045449 1			1	1	1	00018303 1	Verschlussblech	sealing plate	Tôle de ferme- ture	chapa de cierre
10	2	2	2	00044678 2			2	2	2	00044679 2	Wälzlager	roller bearing	Palier à rou- lement	Rodamiento
11	2	2	2	00039955 2			2	2	2	00043828 2	Wellendichtring	shaft seal	Baque á lévres	Retén de eje
12	1	1	1	00043835 1			1	1	1	00043831 1	Wellendichtring	shaft seal	Baque á lévres	Retén de eje
13	2	2	2	00043752 2			2	2	2	00043753 2	Sicherungsring	circlip	Bague de sécu- rité	Anillo de segu- ridad
14	1	1	1	00043738 1			1	1	1	00043744 1	Sicherungsring	circlip	Bague de sécu- rité	Anillo de segu- ridad
15	2	2	2	00043707 2			2	2	2		Schraube	bolt	Vis	Tornillo
16	8	8	8	00043651 8			8	8	8	00043720 8	Schraube	bolt	Vis	Tornillo
17	2	2	2	00043249 2			2	2	2		Scheibe	washer	Disque	Arandela
18	8	8	8	00043769 8			8	8	8		Scheibe	washer	Disque	Arandela

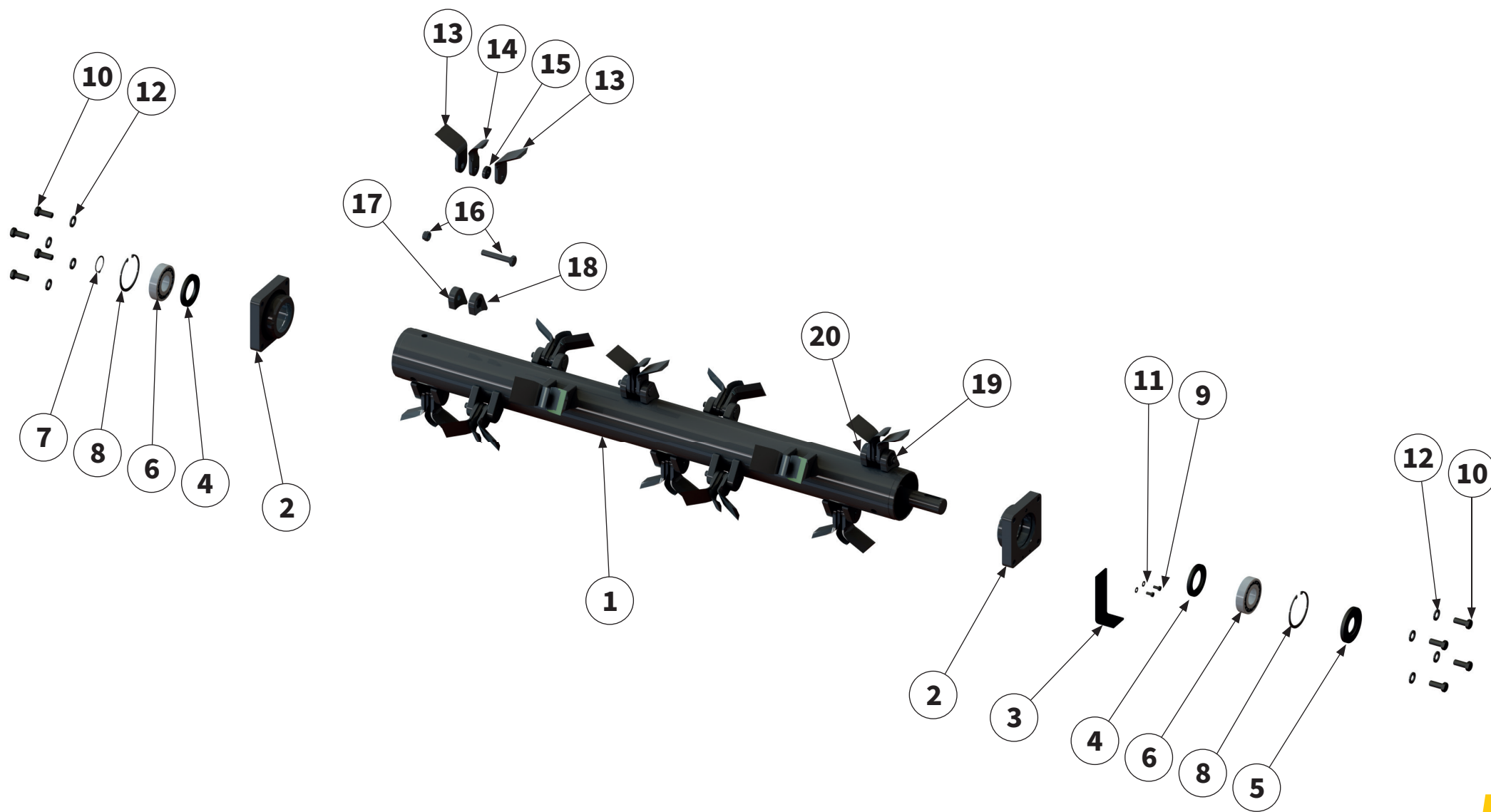

Pos.-Nr. No. Número Número	Ersatzteilnummer Manufacturer part number Numéro d'article du fabricant Número de pieza del fabricante							DE Bezeichnung	EN Designation	FR Désignation	ES Designación
	Anzahl quantity quantité número										
	MU-H 120	MU-H 140	MU-H 150	MU-H 160	MU-H 180	MU-H 200	MU-H 220				
1	00042264 1	00042261 1	00042251 1	00042249 1	00042247 1	00042241 1	00035399 1	Rotor inkl. Werkzeug	rotor with tools	Rotor avec outils	Rotor con herram
2	00045455						00003977 2	Rotorlager- schale	rotor bearing shell	Rotor coussinet	Cojinete del rotor
3	00045449						00018303 1	Verschlussblech	sealing plate	Tôle de fermeture	chapa de cierre
4	00039955						00043828 2	Wellen- dichtring	shaft seal	Bague à lèvres	Retén de eje
5	00043835						00043831 1	Wellen- dichtring	shaft seal	Bague à lèvres	Retén de eje
6	00044678						00044679 2	Wälzlager	roller bearing	Palier à roulement	Rodamiento
7	00043738						00043744 1	Sicherungsring	circlip	Bague de sécu- rité	Anillo de seguridad
8	00043752						00043753 2	Sicherungsring	circlip	Bague de sécu- rité	Anillo de seguridad
9	00043707						2	Schraube	bolt	Vis	Tornillo
10	00043651						00043720 8	Schraube	bolt	Vis	Tornillo
11	00043249						2	Scheibe	washer	Disque	Arandela
12	00043769						8	Scheibe	washer	Disque	Arandela
13	00001437						20 24 24 28 32 32 36	Y-Messer	Y-blade	Couteau en Y action	Cuchilla en Y de hojas
14	00001435						10 12 12 14 16 16 18	Y-Messer	Y-blade	Couteau en Y action	Cuchilla en Y de hojas
15	00001433						10 12 12 14 16 16 18	Buchse	bushing	Manchon	Cojinete
16	00018734						10 12 12 14 16 16 18	Schraube mit Mutter	bolt with nut	Vis avec écrou	Tornillo con tuerca

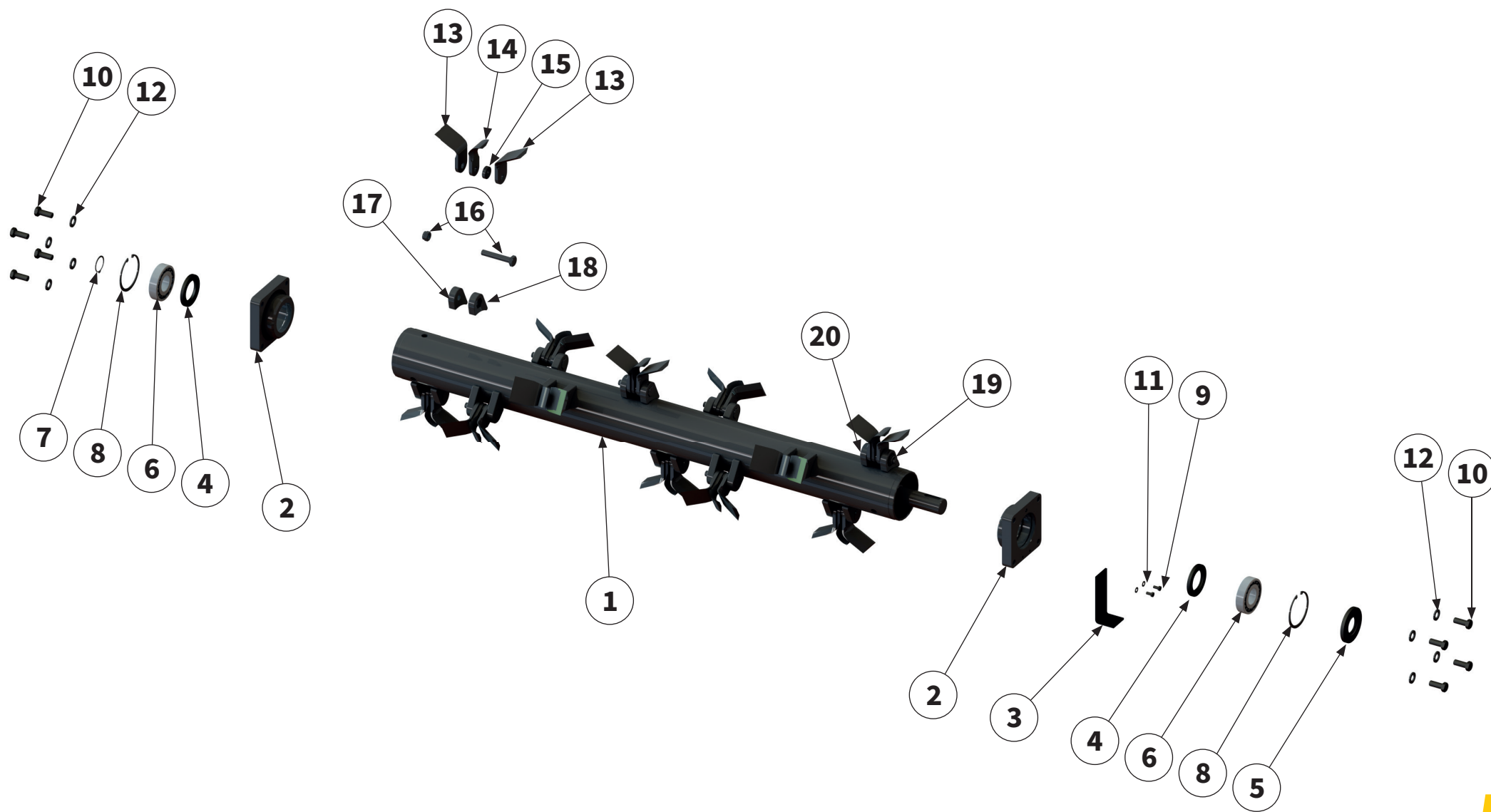

Pos.- Nr. No. Numéro Número	Ersatzteilnummer Manufacturer part number Numéro d'article du fabricant Número de pieza del fabricante							DE Bezeichnung	EN Designation	FR Désignation	ES Designación
	Anzahl quantity quantité número										
	MU-H 120	MU-H 140	MU-H 150	MU-H 160	MU-H 180	MU-H 200	MU-H 220				
17	00013633							Werkzeug- halter rund rechts	tool holders round right	Porte-outils rond à droite	Porta herra redondo derecha
	9	11	11	13	15	15	17				
18	00013632							Werkzeug- halter mit Sechskant links	tool holders with hexagon left	Porte-outils à six pans à gauche	Porta herramien- tas con hexago- nal izquierda
	9	11	11	13	15	15	17				
19	00019323							Werkzeug- halter rund links	tool holders round left	Porte-outils rond à gauche	Porta herramien- tas redondo izquierda
	1	1	1	1	1	1	1				
20	00019322							Werkzeug- halter mit Sechskant rechts	tool holders with hexagon right	Porte-outils à six pans à droite	Porta herramien- tas con hexago- nal derecha
	1	1	1	1	1	1	1				

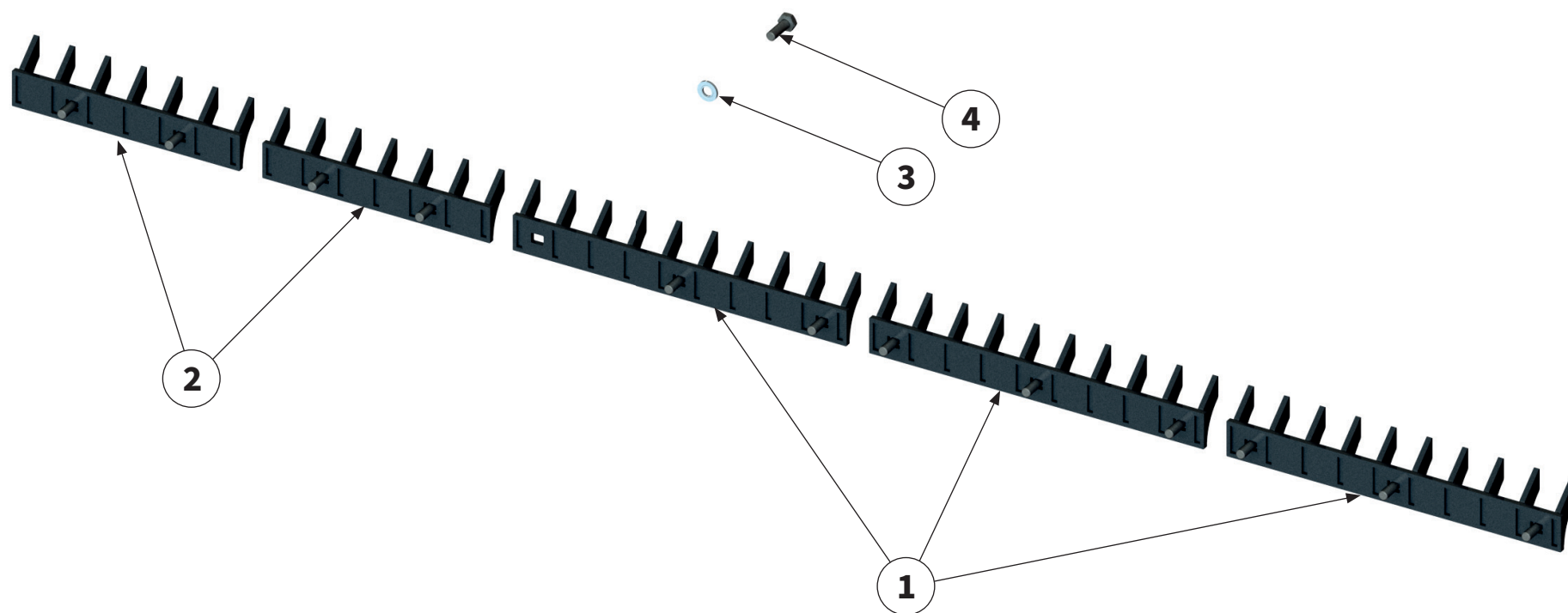

Pos.-Nr. No. Numéro Número	Ersatzteilnummer Manufacturer part number Numéro d'article du fabricant Número de pieza del fabricante							DE Bezeichnung	EN Designation	FR Désignation	ES Designación
	Anzahl quantity quantité número										
	MU-H 120	MU-H 140	MU-H 150	MU-H 160	MU-H 180	MU-H 200	MU-H 220				
Maschine mit Hammerrotor Machine with Hammer rotor Machine avec Rotor à marteaux Máquina con Rotor de martillo 											
1	2	2	-	3	3	4	4	Gegen- schneide 400	short-chopping bar	Lame hache- paille courte	Listón de corte de paja corto
2	1	2	5	1	2	1	2	Gegen- schneide 300	short-chopping bar	Lame hache- paille courte	Listón de corte de paja corto
3	8	10	10	11	13	14	16	Schraube	bolt	Vis	Tornillo
4	8	10	10	11	13	14	16	Scheibe	washer	Disque	Arandela
Maschine mit Schäkelrotor Machine with Shackle rotor Machine avec Rotor à manilles Máquina con Rotor de grilletes 											
1	2	2	-	3	3	4	4	Gegen- schneide 400	short-chopping bar	Lame hache- paille courte	Listón de corte de paja corto
2	1	2	5	1	2	1	2	Gegen- schneide 300	short-chopping bar	Lame hache- paille courte	Listón de corte de paja corto
3	8	10	10	11	13	14	16	Schraube	bolt	Vis	Tornillo
4	8	10	10	11	13	14	16	Scheibe	washer	Disque	Arandela

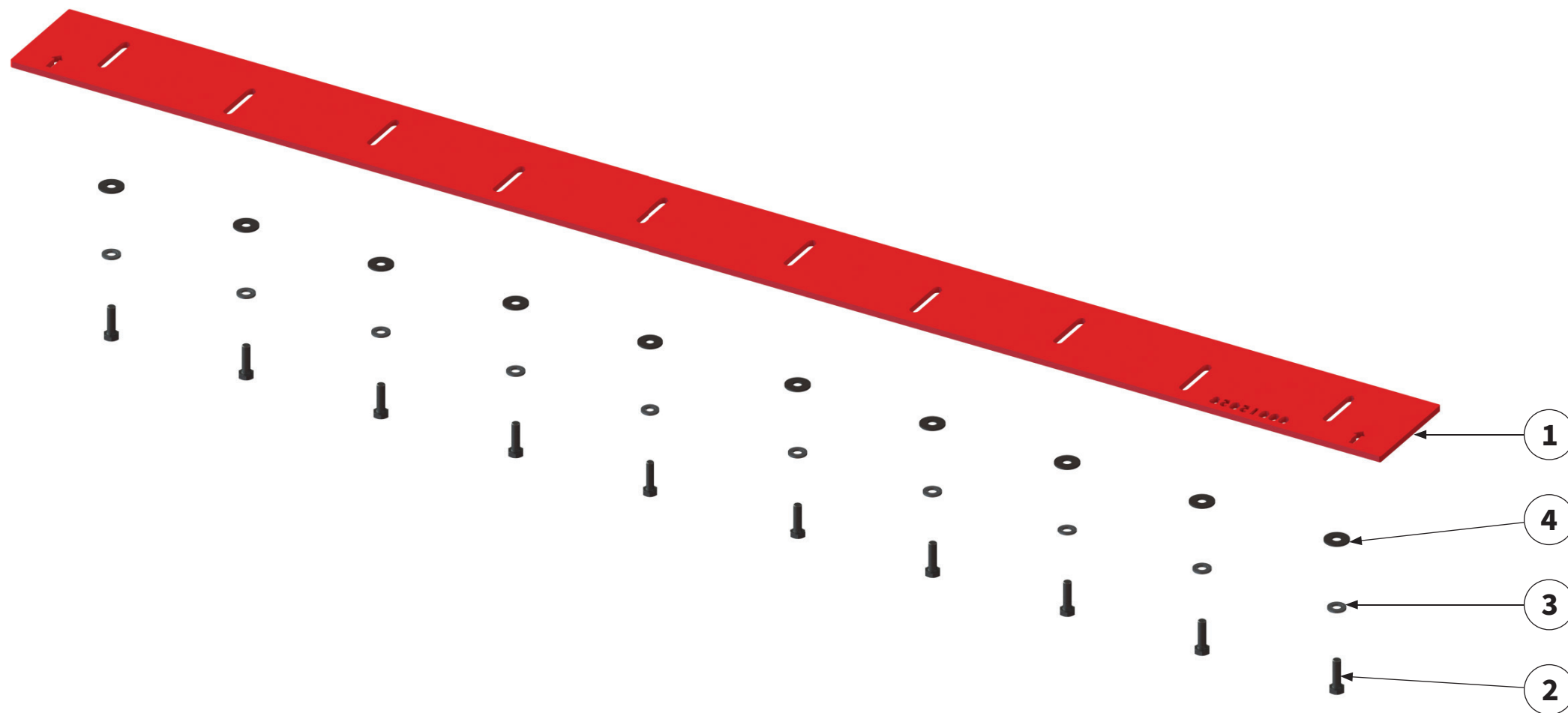

Pos.-Nr. No. Numéro Número	Ersatzteilnummer Manufacturer part number Numéro d'article du fabricant Número de pieza del fabricante							DE Bezeichnung	EN Designation	FR Désignation	ES Designación
	Anzahl quantity quantité número										
	MU-H 120	MU-H 140	MU-H 150	MU-H 160	MU-H 180	MU-H 200	MU-H 220				
1	00015070 1	00015067 1	00015064 1	00015061 1	00015058 1	00015055 1	00015052 1	Schneidblech	cutting bar	Contre-lame réglable	Carril de corte
2	00043603							Schraube	bolt	Vis	Tornillo
3	00043281							Scheibe	washer	Disque	Arandela
4	00043766							Scheibe	washer	Disque	Arandela



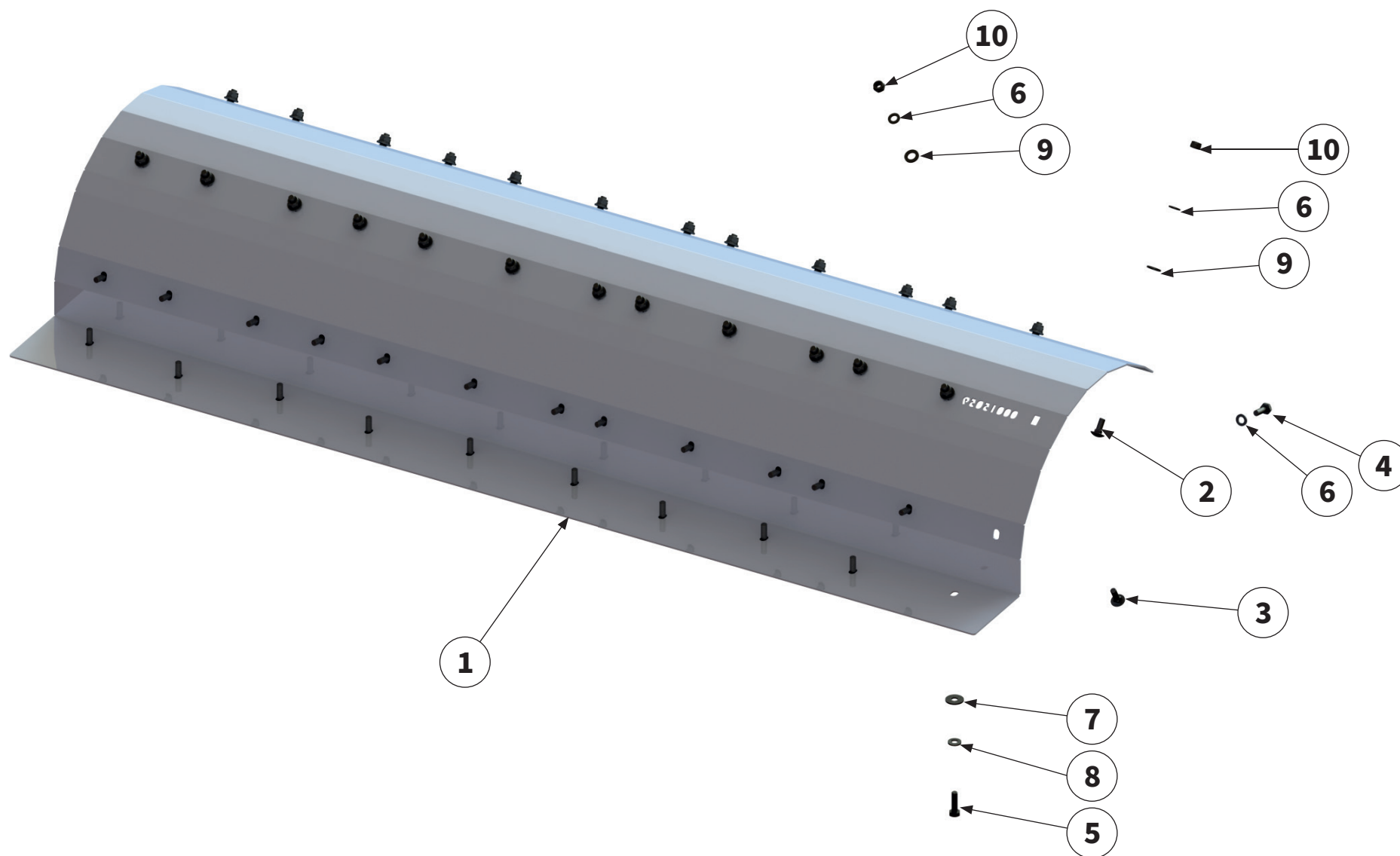

Pos.-Nr. No. Numéro Número	Ersatzteilnummer Manufacturer part number Numéro d'article du fabricant Número de pieza del fabricante							DE Bezeichnung	EN Designation	FR Désignation	ES designación
	Anzahl quantity quantité número										
	MU-H 120	MU-H 140	MU-H 150	MU-H 160	MU-H 180	MU-H 200	MU-H 220				
1	00015071 1	00015068 1	00015065 1	00015062 1	00015059 1	00015056 1	00015053 1	Verschleiß- einlage	wear insert	Blindage	Junta de desgaste
2	00000903							Schraube	bolt	Vis	Tornillo
3	8	10	10	11	13	14	16	Schraube	bolt	Vis	Tornillo
4	00000904							Schraube	bolt	Vis	Tornillo
5	8	10	10	11	13	14	16	Schraube	bolt	Vis	Tornillo
6	00043602							Schraube	bolt	Vis	Tornillo
7	8	8	10	10	10	12	12	Schraube	bolt	Vis	Tornillo
8	00043232							Scheibe	washer	Disque	Arandela
9	24	30	30	33	39	42	48	Scheibe	washer	Disque	Arandela
10	00043281							Scheibe	washer	Disque	Arandela
11	8	8	10	10	10	12	12	Scheibe	washer	Disque	Arandela
12	00043766							Scheibe	washer	Disque	Arandela
13	8	8	10	10	10	12	12	Scheibe	washer	Disque	Arandela
14	00043233							Scheibe	washer	Disque	Arandela
15	16	20	20	22	26	28	32	Scheibe	washer	Disque	Arandela
16	00043177							Mutter	nut	Écrou	Tuerca
17	16	20	20	22	26	28	32	Mutter	nut	Écrou	Tuerca



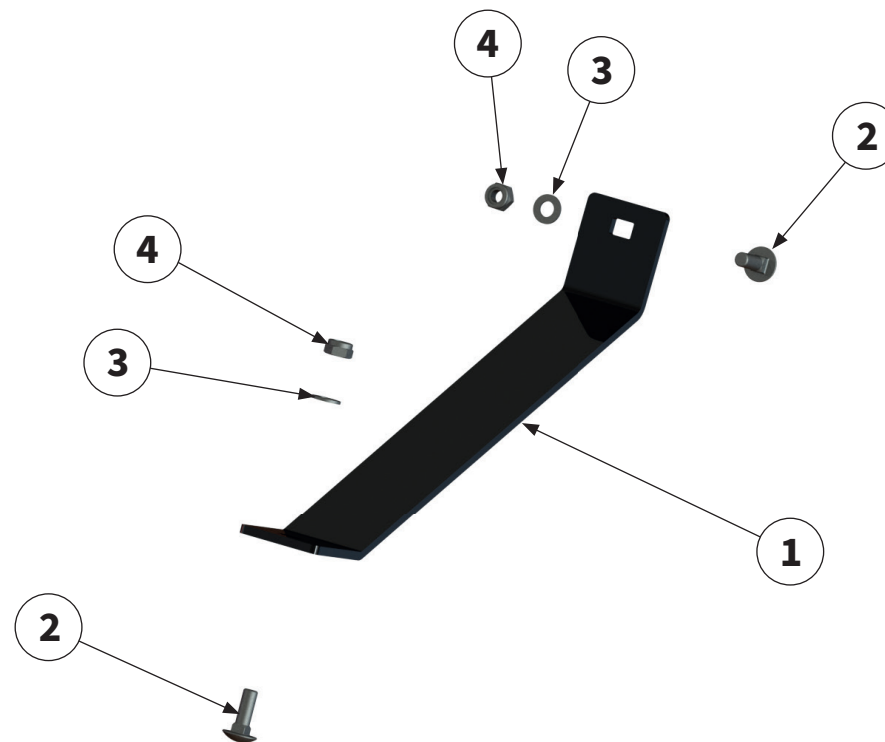
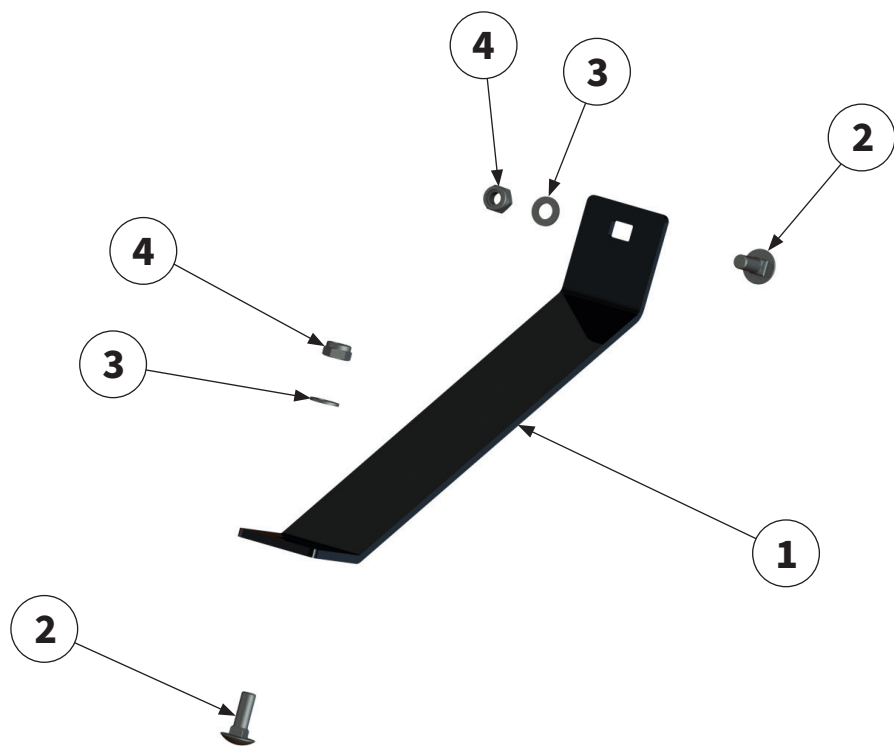

Pos.-Nr. No. Numéro Número	Ersatzteilnummer Manufacturer part number Numéro d'article du fabricant Número de pieza del fabricante							DE Bezeichnung	EN Designation	FR Désignation	ES Designación
	Anzahl quantity quantité número										
	MU-H 120	MU-H 140	MU-H 150	MU-H 160	MU-H 180	MU-H 200	MU-H 220				
1	2	2	2	2	2	2	2	Verschleißkufe	wear runner	Patin d'usure	Cuchilla de desgaste
2	4	4	4	4	4	4	4	Schraube	bolt	Vis	Tornillo
3	4	4	4	4	4	4	4	Scheibe	washer	Disque	Arandela
4	4	4	4	4	4	4	4	Mutter	nut	Écrou	Tuerca

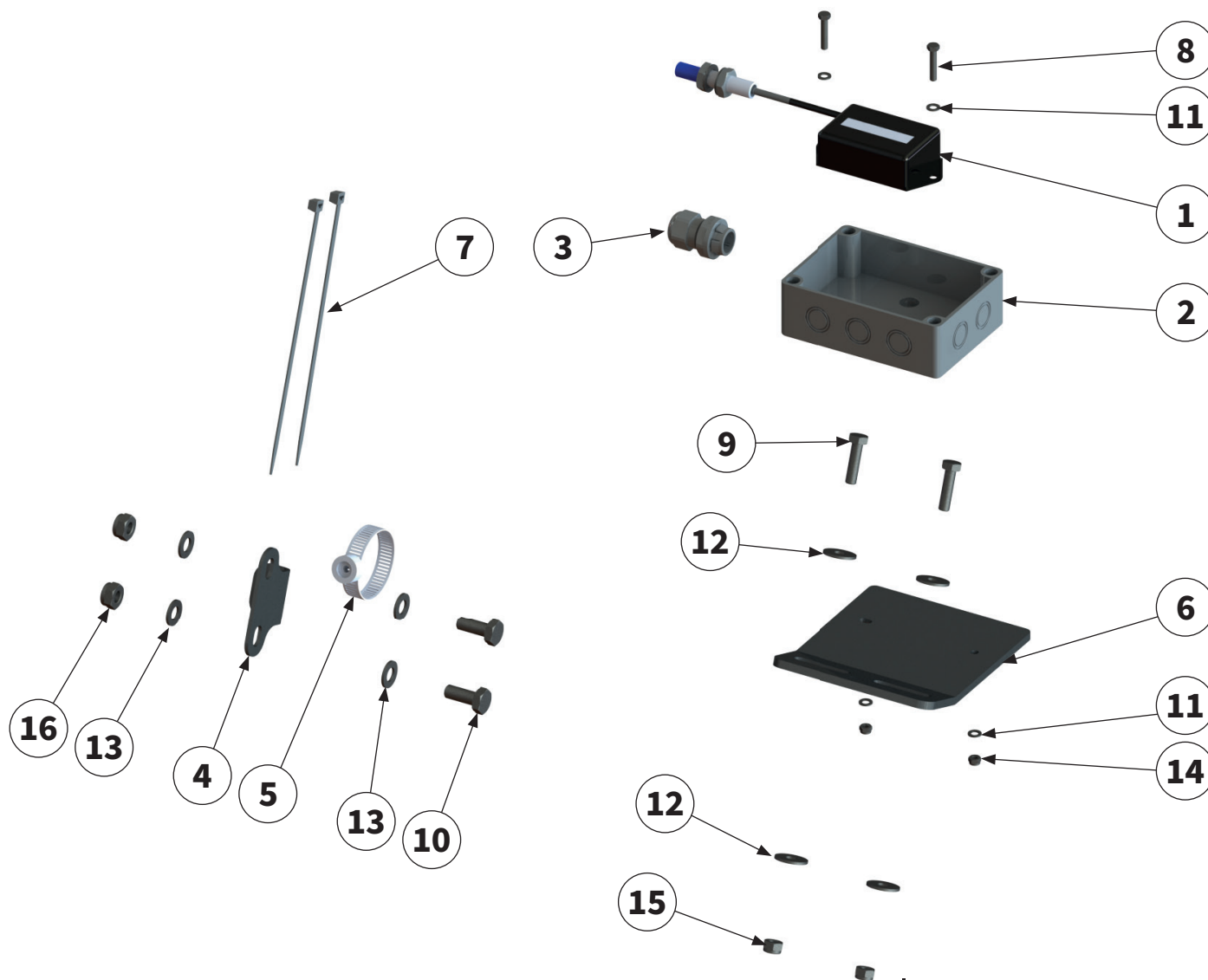

Pos.-Nr. No. Numéro Número	Ersatzteilnummer Manufacturer part number Numéro d'article du fabricant Número de pieza del fabricante							DE Bezeichnung	EN Designation	FR Désignation	ES Designación	
	Anzahl quantity quantité número											
	MU-H 120	MU-H 140	MU-H 150	MU-H 160	MU-H 180	MU-H 200	MU-H 220					
1	1	1	1	00015048 1	1	1	1	1	Betriebsstun- denzähler	Operating hours counter	Compteur horaire	Contador de horas de servicio
2	1	1	1	00010187 1	1	1	1	1	Verteiler- kasten	distribution box	Boîte de distribution	Caja de distribución
3	1	1	1	00008094 1	1	1	1	1	Einrastver- schraubung	srew connection	Connexion à vis	Conexión por tornillo
4	1	1	1	00015050 1	1	1	1	1	Sensor- halterung	holder	Support	Soporte
5	1	1	1	00017319 1	1	1	1	1	Drehzahl- gebermagnet	engine speed sensor magnet	Régulateur de vitesse Aimant	Transmisor del número de revo- luciones Imán
6	1	1	1	00015049 1	1	1	1	1	Halter	holder	Support	Soporte
7	2	2	2	00044494 2	2	2	2	2	Kabelbinder	cable tie	Attache-câbles	Agavillador de cables
8	2	2	2	00043687 2	2	2	2	2	Schraube	bolt	Vis	Tornillo
9	2	2	2	00043710 2	2	2	2	2	Schraube	bolt	Vis	Tornillo
10	2	2	2	00043601 2	2	2	2	2	Schraube	bolt	Vis	Tornillo
11	4	4	4	00043247 4	4	4	4	4	Scheibe	washer	Disque	Arandela
12	4	4	4	00043286 4	4	4	4	4	Scheibe	washer	Disque	Arandela
13	4	4	4	00043232 4	4	4	4	4	Scheibe	washer	Disque	Arandela
14	2	2	2	00043189 2	2	2	2	2	Mutter	nut	Écrou	Tuerca
15	2	2	2	00043191 2	2	2	2	2	Mutter	nut	Écrou	Tuerca
16	2	2	2	00043177 2	2	2	2	2	Mutter	nut	Écrou	Tuerca

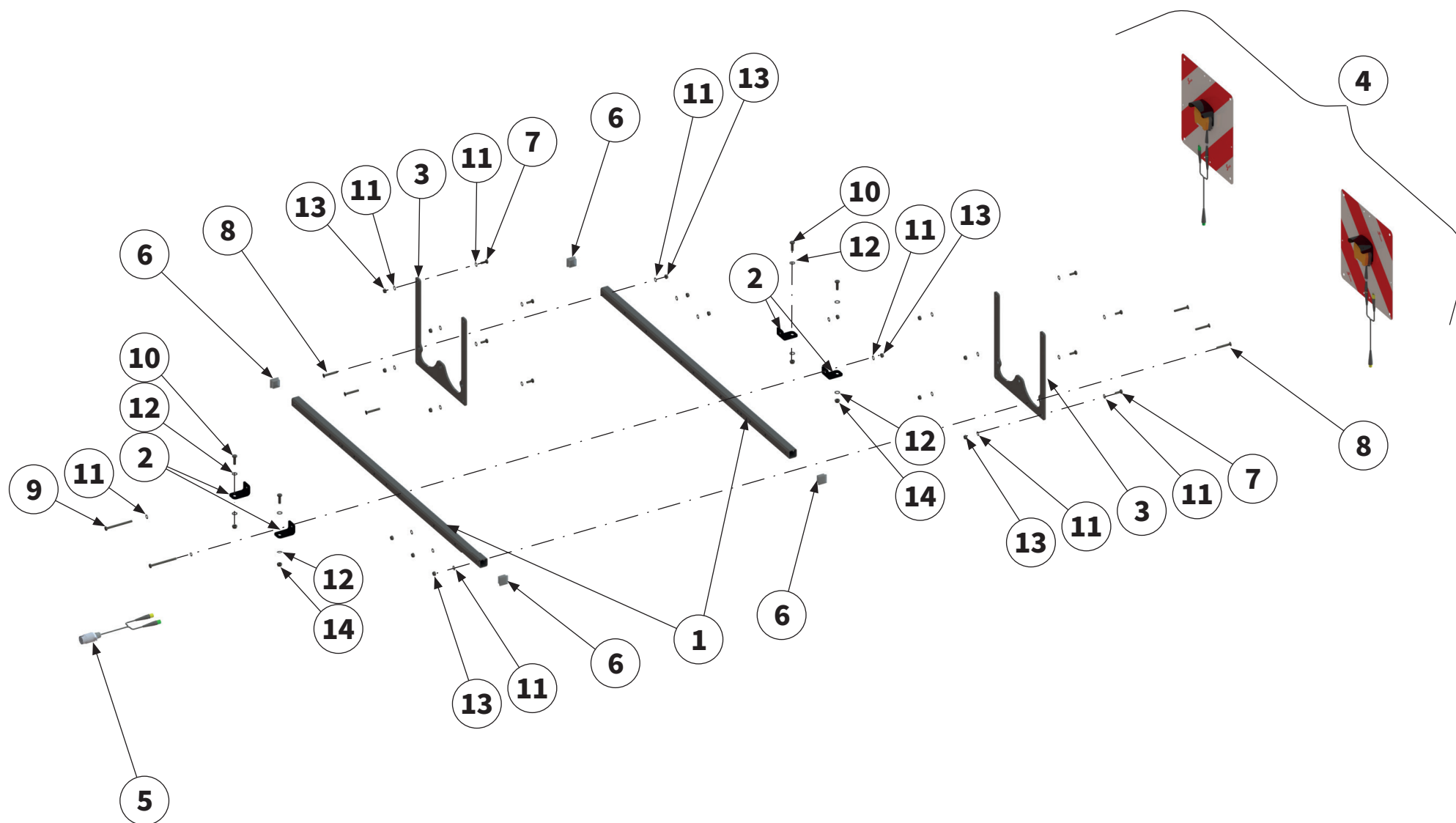

Pos.-Nr. No. Número	Ersatzteilnummer Manufacturer part number Numéro d'article du fabricant Número de pieza del fabricante							DE Bezeichnung	EN Designation	FR Désignation	ES designación
	Anzahl quantity quantité número										
	MU-H 120	MU-H 140	MU-H 150	MU-H 160	MU-H 180	MU-H 200	MU-H 220				
1	-	2	2	2	2	2	2	Rechteckrohr	rectangular pipe	Racleur	Tubo de sección rectangular
2	-	4	4	4	4	4	4	Halter	holder	Support	Soporte
3	-	2	2	2	2	2	2	Warntafelhalter	warning sign holder	Support de panneau de signalisation	Soporte del panel de aviso
4	-	1	1	1	1	1	1	Warntafel mit Beleuchtungseinrichtung	warning sign with lighting equipment	Panneau de signalisation avec système d'éclairage	Panel de aviso con dispositivo de iluminación
5	-	1	1	1	1	1	1	Kabelbaum	wiring harness	Faisceau de câblage	Arnés de cableado
6	-	4	4	4	4	4	4	Verschlussstopfen	sealing plug	Bouchon de fermeture	Tapón de cierre
7	-	8	8	8	8	8	8	Schraube	bolt	Vis	Tornillo
8	-	6	6	6	6	6	6	Schraube	bolt	Vis	Tornillo
9	-	2	2	2	2	2	2	Schraube	bolt	Vis	Tornillo
10	-	4	4	4	4	4	4	Schraube	bolt	Vis	Tornillo
11	-	24	24	24	24	24	24	Scheibe	washer	Disque	Arandela
12	-	8	8	8	8	8	8	Scheibe	washer	Disque	Arandela
13	-	16	16	16	16	16	16	Mutter	nut	Écrou	Tuerca
14	-	4	4	4	4	4	4	Mutter	nut	Écrou	Tuerca

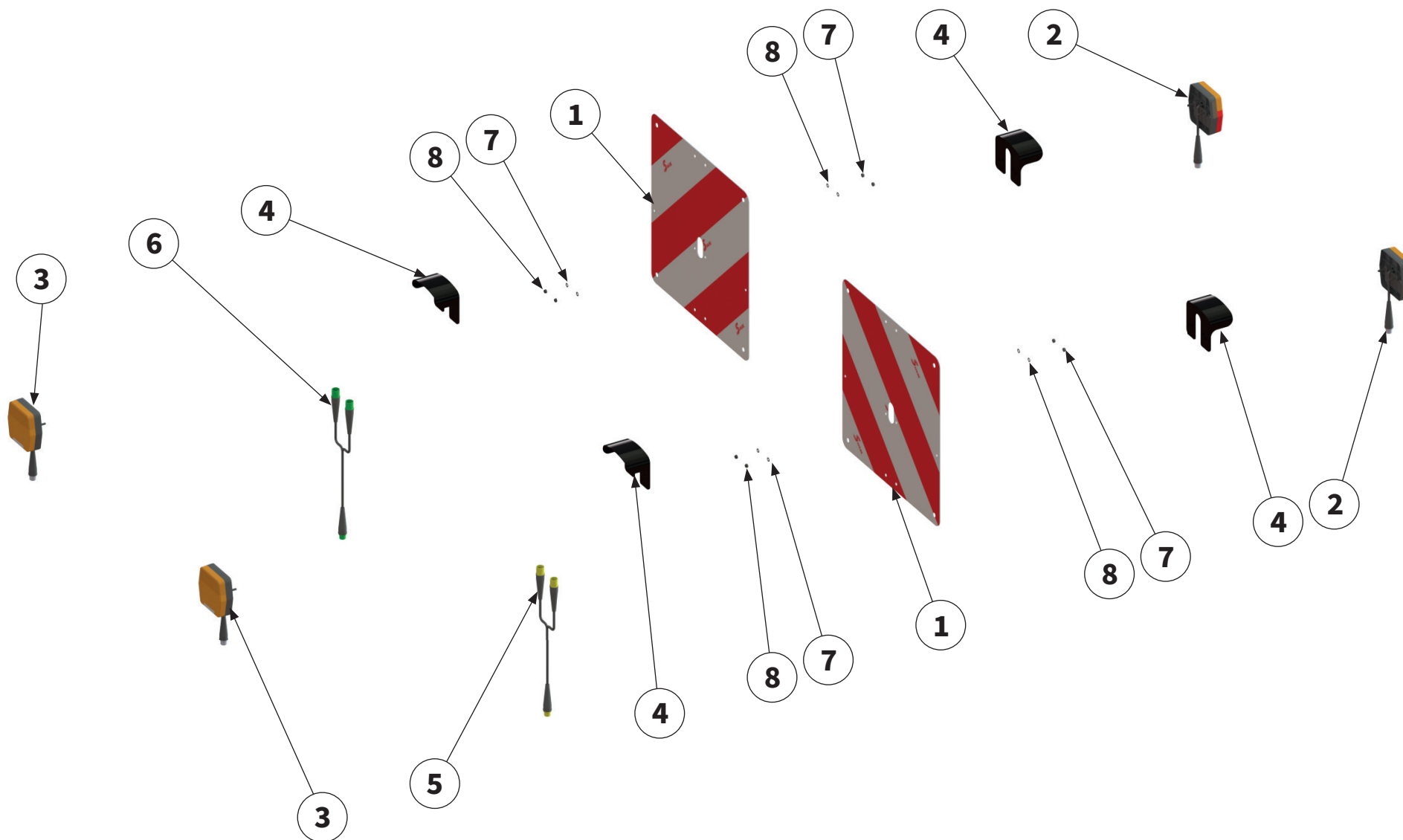

Pos.-Nr. No. numéro número	Ersatzteilnummer Manufacturer part number Numéro d'article du fabricant Número de pieza del fabricante							DE Bezeichnung	EN designation	FR désignation	ES designación	
	Anzahl quantity quantité número											
	MU-H 120	MU-H 140	MU-H 150	MU-H 160	MU-H 180	MU-H 200	MU-H 220					
1	-	2	2	2	2	2	2	Warntafel	warning sign	Panneau de signalisation	Panel de aviso	
		40012689										
2	-	2	2	2	2	2	2	LED Blinkerleuchte	LED Direction indicator	LED- luminaire fclignotant	LED-lámpara intermitente	
		90158070										
3	-	2	2	2	2	2	2	LED Positionsleuchte	LED position light	LED position clignotant	LED Pilotos delanteros de posición	
		90315801										
4	-	1	1	1	1	1	1	Kabelbaum gelb	wiring harness yellow	Faisceau de câblage jaune	Arnés de cableado amarillo	
		00035255										
5	-	1	1	1	1	1	1	Kabelbaum grün	wiring harness green	Faisceau de câblage vert	Arnés de cableado verde	
		00035256										
6	-	4	4	4	4	4	4	Schutzabdeckung	protection cover	Recouvrement de protection	Cubierta protectora	
		00034127										
7	-	8	8	8	8	8	8	Scheibe	washer	Disque	Arandela	
		00043233										
8	-	16	16	16	16	16	16	Mutter	nut	Écrou	Tuerca	
		00043177										



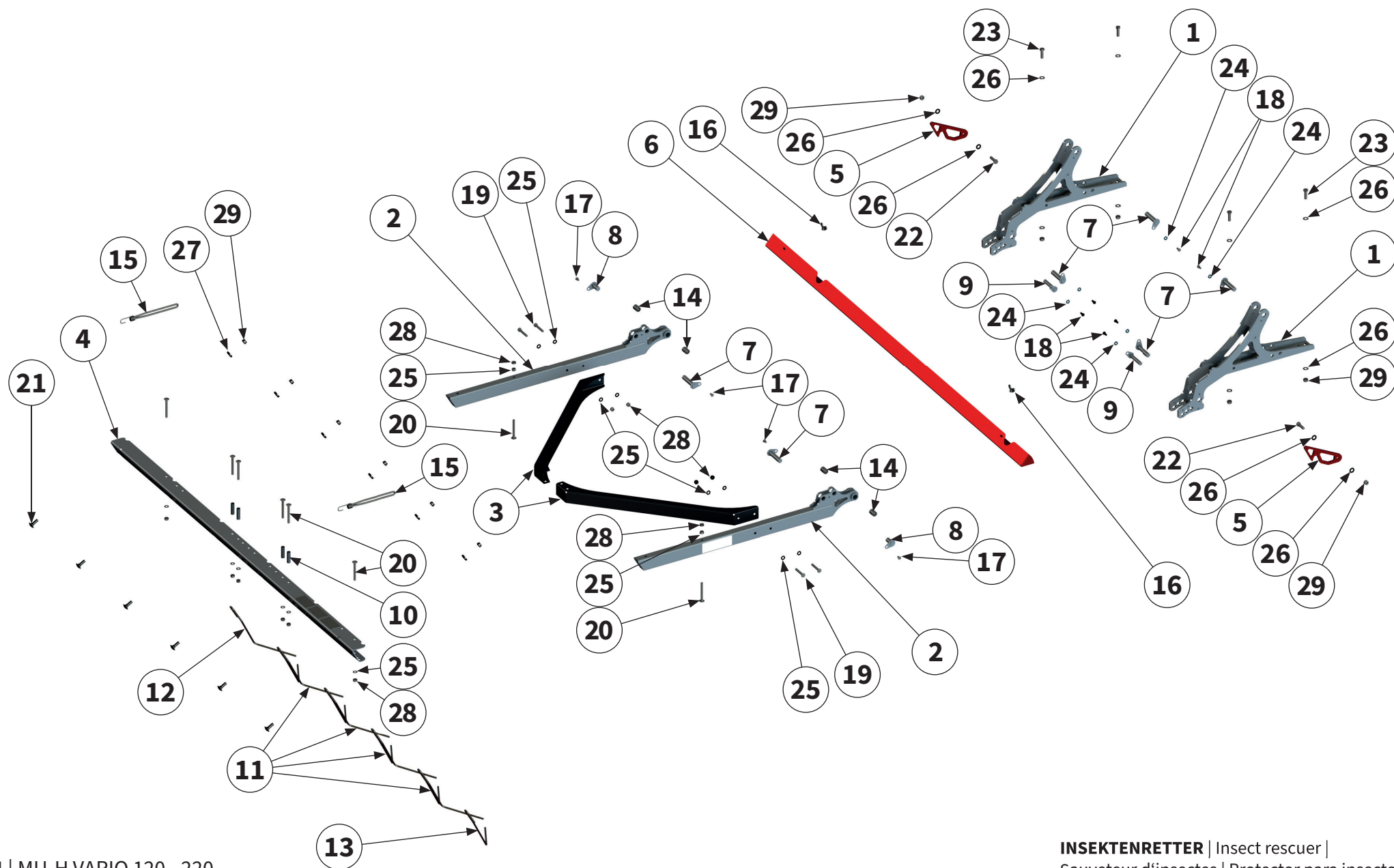

Pos.-Nr. No. Número Número	Ersatzteilnummer Manufacturer part number Numéro d'article du fabricant Número de pieza del fabricante							DE Bezeichnung	EN Designation	FR Désignation	ES Designación	
	Anzahl quantity quantité número											
	MU-H 120	MU-H 140	MU-H 150	MU-H 160	MU-H 180	MU-H 200	MU-H 220					
1	-	-	-	2	2	2	2	00042579	Aufnahme	holder	Support	Alojamiento
2	-	-	-	2	2	2	2	00042583	Tragarm	support arm	Bras porteur	Brazo portante
3	-	-	-	2	2	2	2	00042420	Versteifungs- strebe	Reinforcing strut	Tirant de renforcement	Tirante
4	-	-	-	1	1	1	1	00042595	Aufnahme	holder	Support	Alojamiento
5	-	-	-	2	2	2	2	00042580	Sicherungs- haken	securing hook	Crochet de sécurité	Gancho de retención
6	-	-	-	00045867 1	00045870 1	00045859 1	00045855 1	00045855	Schutz- vorrichtung	safety device	Protection	Dispositivo de protección
7	-	-	-	6	6	6	6	00044879	Bolzen	pin	Axe	Perno
8	-	-	-	2	2	2	2	00044885	Bolzen	pin	Axe	Perno
9	-	-	-	2	2	2	2	00044890	Bolzen	pin	Axe	Perno
10	-	-	-	4	4	4	4	00044831	Rundrohr	circular pipe	Tuyau rond	Tubo redondo
11	-	-	-	5	4	5	6	00037091	Zinken	tines	Dents	Dientes
12	-	-	-	-	1	1	-	00041929	Zinken	tines	Dents	Dientes
13	-	-	-	-	1	-	-	00041930	Zinken	tines	Dents	Dientes
14	-	-	-	4	4	4	4	00044878	Gleitlager	sleeve bearing	Palier lisse	Cojinete de deslizamiento
15	-	-	-	2	2	2	2	00047270	Spanngummi	Bungee cord	Cordon élastique	Cuerda elástica
16	-	-	-	2	2	2	2	00045843	Flügelmutter	Wing nut	Écrou papillon	Tuerca de mari- posa

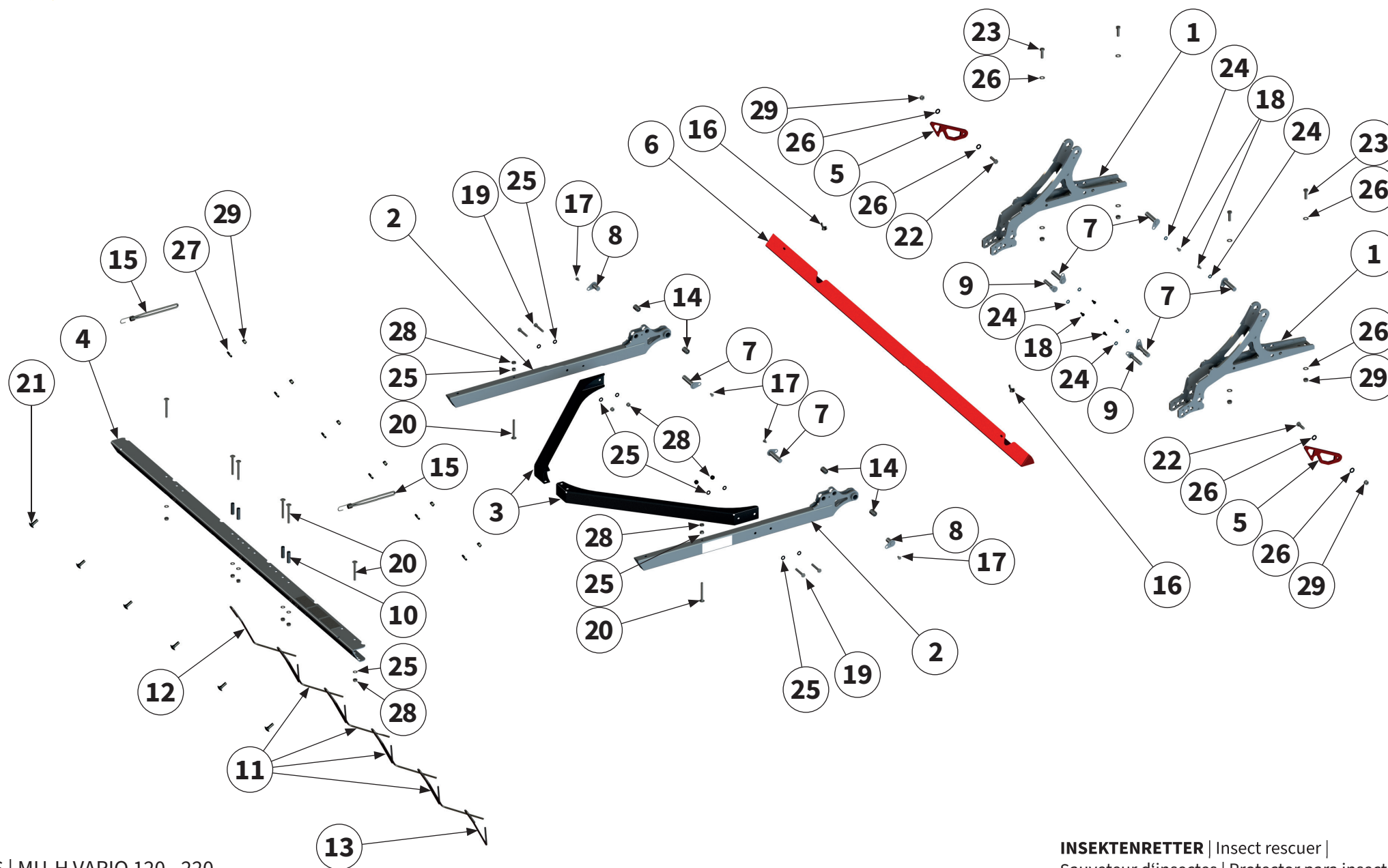

Pos.-Nr. No. Número Número	Ersatzteilnummer Manufacturer part number Numéro d'article du fabricant Número de pieza del fabricante							DE Bezeichnung	EN Designation	FR Désignation	ES Designación
	Anzahl quantity quantité número										
	MU-H 120	MU-H 140	MU-H 150	MU-H 160	MU-H 180	MU-H 200	MU-H 220				
17	-	-	-	4	4	4	4	Schraube	bolt	Vis	Tornillo
						00043704					
18	-	-	-	6	6	6	6	Schraube	bolt	Vis	Tornillo
						00043707					
19	-	-	-	4	4	4	4	Schraube	bolt	Vis	Tornillo
						00043479					
20	-	-	-	8	8	8	8	Schraube	bolt	Vis	Tornillo
						00043330					
21	-	-	-	5	6	6	6	Schraube	bolt	Vis	Tornillo
						00043333					
22	-	-	-	2	2	2	2	Schraube	bolt	Vis	Tornillo
						00043495					
23	-	-	-	4	4	4	4	Schraube	bolt	Vis	Tornillo
						00043622					
24	-	-	-	6	6	6	6	Scheibe	washer	Disque	Arandela
						00043771					
25	-	-	-	18	18	18	18	Scheibe	washer	Disque	Arandela
						00043232					
26	-	-	-	12	12	12	12	Scheibe	washer	Disque	Arandela
						00043233					
27	-	-	-	5	6	6	6	Scheibe	washer	Disque	Arandela
						00043263					
28	-	-	-	12	12	12	12	Mutter	nut	Écrou	Tuerca
						00043177					
29	-	-	-	11	11	11	11	Mutter	nut	Écrou	Tuerca
						00043178					

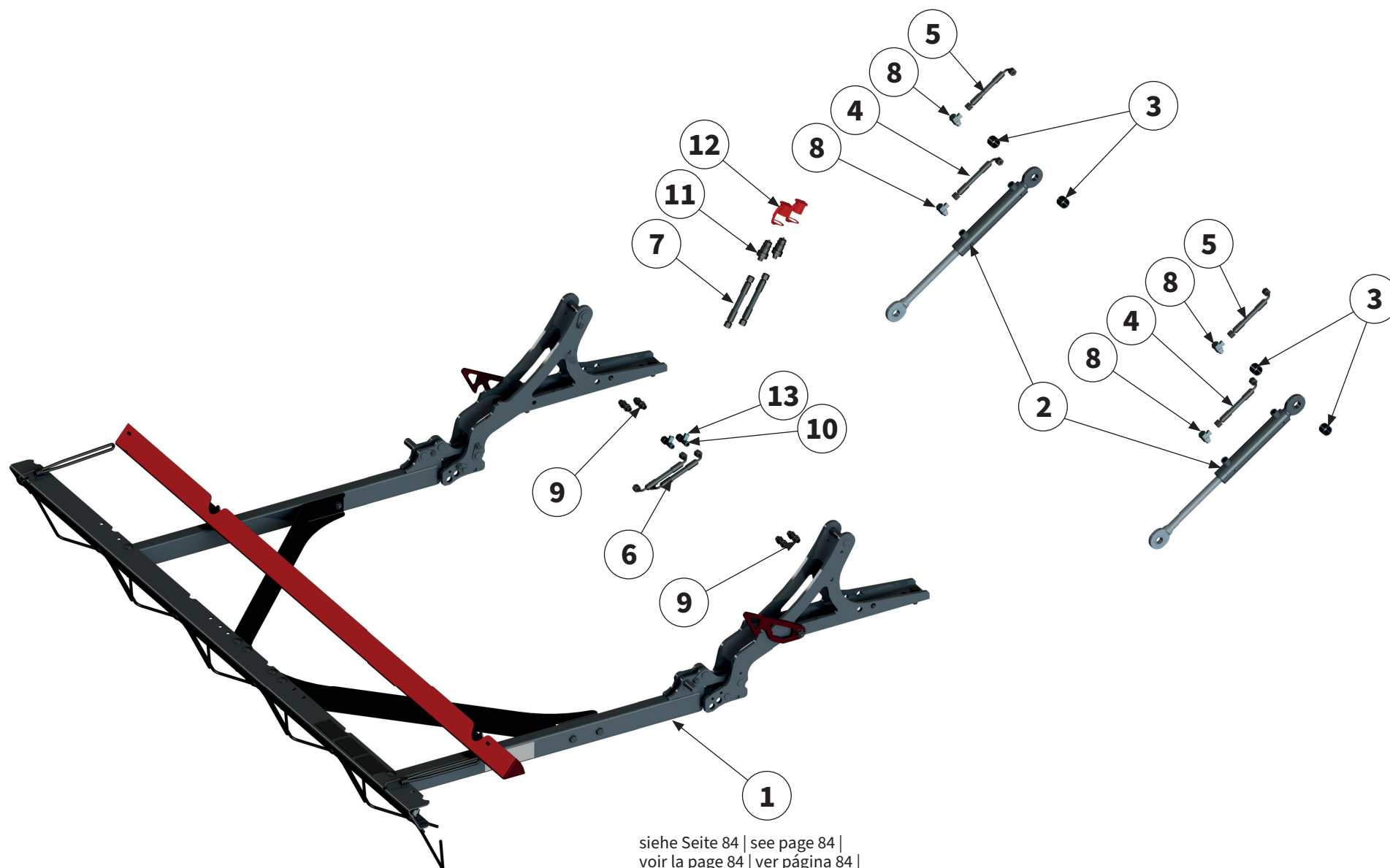

siehe Seite 84 | see page 84 |
voir la page 84 | ver página 84 |

Pos.-Nr. No. Número Número	Ersatzteilnummer Manufacturer part number Numéro d'article du fabricant Número de pieza del fabricante							DE Bezeichnung	EN Designation	FR Désignation	ES Designación
	Anzahl quantity quantité número										
	MU-H 120	MU-H 140	MU-H 150	MU-H 160	MU-H 180	MU-H 200	MU-H 220				
1	-	-	-	00047000 1 siehe Seite 84 see page 84 voir la page 84 ver página 84	00047001 1	00046808 1	00046806 1	Insektenretter	Insect rescuer	Sauveteur d'insectes	Protector para insectos
2	-	-	-	2	2	2	2	Hydraulikzylinder	hydraulic cylinder	Vérin hydraulique	Cilindro hidráulico
3	-	-	-	4	4	4	4	Rundrohr	circular pipe	Tuyau rond	Tube redondo
4	-	-	-	2	2	2	2	Hydraulikschlauch	hydraulic hose	Tuyau hydraulique	Tube flexible hidráulico
5	-	-	-	2	2	2	2	Hydraulikschlauch	hydraulic hose	Tuyau hydraulique	Tube flexible hidráulico
6	-	-	-	2	2	2	2	Hydraulikschlauch	hydraulic hose	Tuyau hydraulique	Tube flexible hidráulico
7	-	-	-	2	2	2	2	Hydraulikschlauch	hydraulic hose	Tuyau hydraulique	Tube flexible hidráulico
8	-	-	-	4	4	4	4	Verschraubung	threaded connection	Raccord à vis	Unión atornillada
9	-	-	-	4	4	4	4	Verschraubung	threaded connection	Raccord à vis	Unión atornillada
10	-	-	-	2	2	2	2	Verschraubung	threaded connection	Raccord à vis	Unión atornillada
11	-	-	-	2	2	2	2	Hydraulikstecker	hydraulic connector	Raccord hydraulique	Conector hidráulico
12	-	-	-	2	2	2	2	Staubschutzkappe	dust cap	Couvercle anti-poussière	Caperuza guardapolvo
13	-	-	-	2	2	2	2	Scheibe	washer	Disque	Arandela



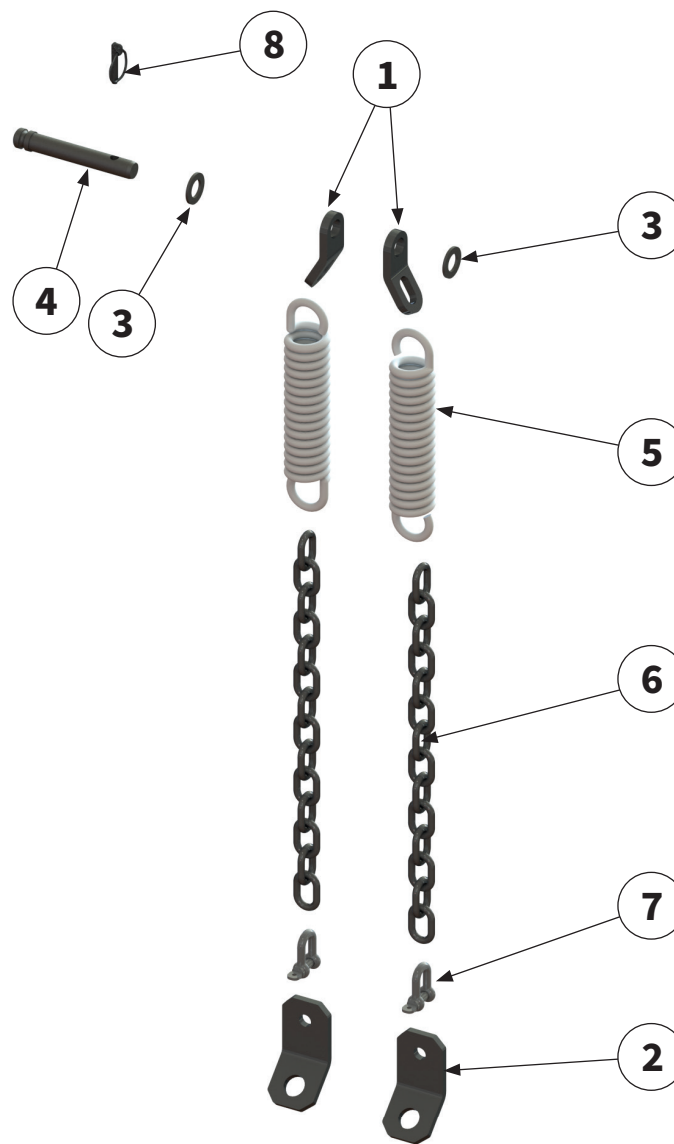

Pos.-Nr. No. Numéro Número	Ersatzteilnummer Manufacturer part number Numéro d'article du fabricant Número de pieza del fabricante							DE Bezeichnung	EN Designation	FR Désignation	ES Designación
	Anzahl quantity quantité número										
	MU-H 120	MU-H 140	MU-H 150	MU-H 160	MU-H 180	MU-H 200	MU-H 220				
1	00039173							Blech	sheet metal	Tôle	Chapa
	2	2	2	2	2	2	2				
2	00001400							Blech	sheet metal	Tôle	Chapa
	2	2	2	2	2	2	2				
3	00043239							Scheibe	washer	Disque	Arandela
	2	2	2	2	2	2	2				
4	00044082							Bolzen	pin	Axe	Perno
	1	1	1	1	1	1	1				
5	00049041							Feder	spring	Ressort	Resorte
	2	2	2	2	2	2	2				
6	00049044							Kette	chain	Chaîne	Cadena
	2	2	2	2	2	2	2				
7	00006273							Schäkel	shackle	Manille	Grillete
	2	2	2	2	2	2	2				
8	00047863							Klappstecker	lynch pin	Esse d'essieu	Pasador abatible
	1	1	1	1	1	1	1				



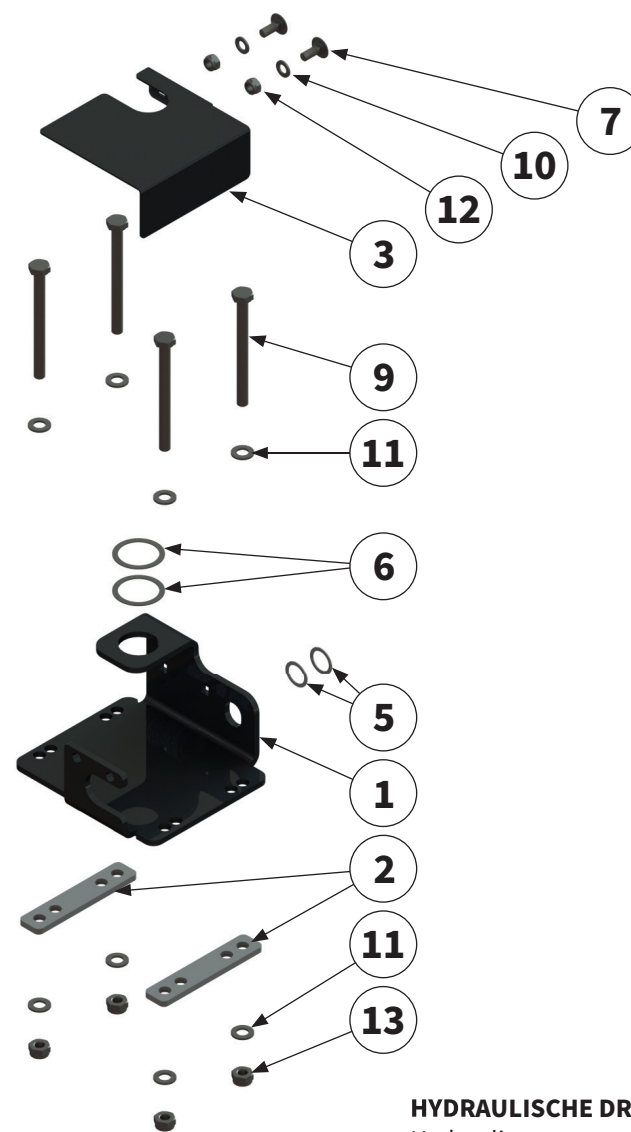
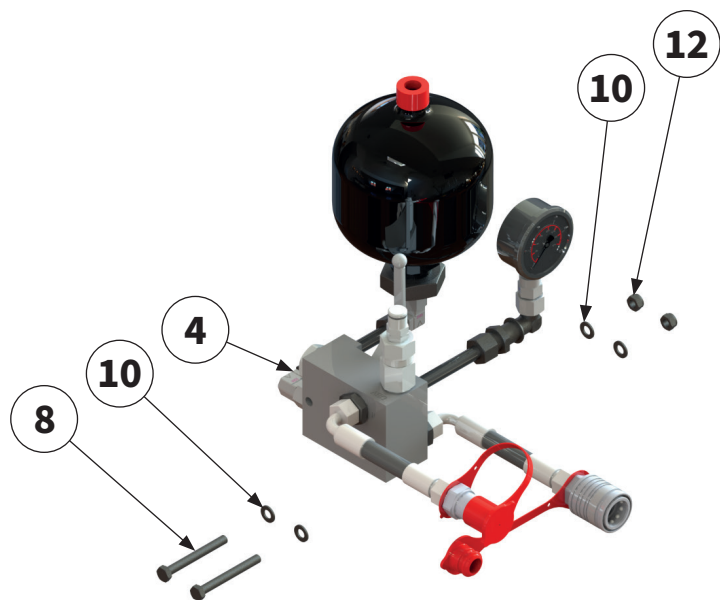

Pos.-Nr. No. Número Número	Ersatzteilnummer Manufacturer part number Numéro d'article du fabricant Número de pieza del fabricante							DE Bezeichnung	EN Designation	FR Désignation	ES Designación
	Anzahl quantity quantité número										
	MU-H 120	MU-H 140	MU-H 150	MU-H 160	MU-H 180	MU-H 200	MU-H 220				
1	1	1	1	1	1	1	1	Blech	sheet metal	Tôle	Chapa
2	2	2	2	2	2	2	2	Blech	sheet metal	Tôle	Chapa
3	1	1	1	1	1	1	1	Blech	sheet metal	Tôle	Chapa
4	1	1	1	1	1	1	1	Hydraulikbau- gruppe	hydraulic as- sembly	Assemblage hydraulique	Ensamble hidráulico
siehe Seite 94 see page 94 voir page 94 ver página94											
5	2	2	2	2	2	2	2	Passscheibe	shim	Rondelle d'ajustage	Arandela de ajuste
6	2	2	2	2	2	2	2	Passscheibe	shim	Rondelle d'ajustage	Arandela de ajuste
7	2	2	2	2	2	2	2	Schraube	bolt	Vis	Tornillo
8	2	2	2	2	2	2	2	Schraube	bolt	Vis	Tornillo
9	4	4	4	4	4	4	4	Schraube	bolt	Vis	Tornillo
10	6	6	6	6	6	6	6	Scheibe	washer	Disque	Arandela
11	8	8	8	8	8	8	8	Scheibe	washer	Disque	Arandela
12	4	4	4	4	4	4	4	Mutter	nut	Écrou	Tuerca
13	4	4	4	4	4	4	4	Mutter	nut	Écrou	Tuerca



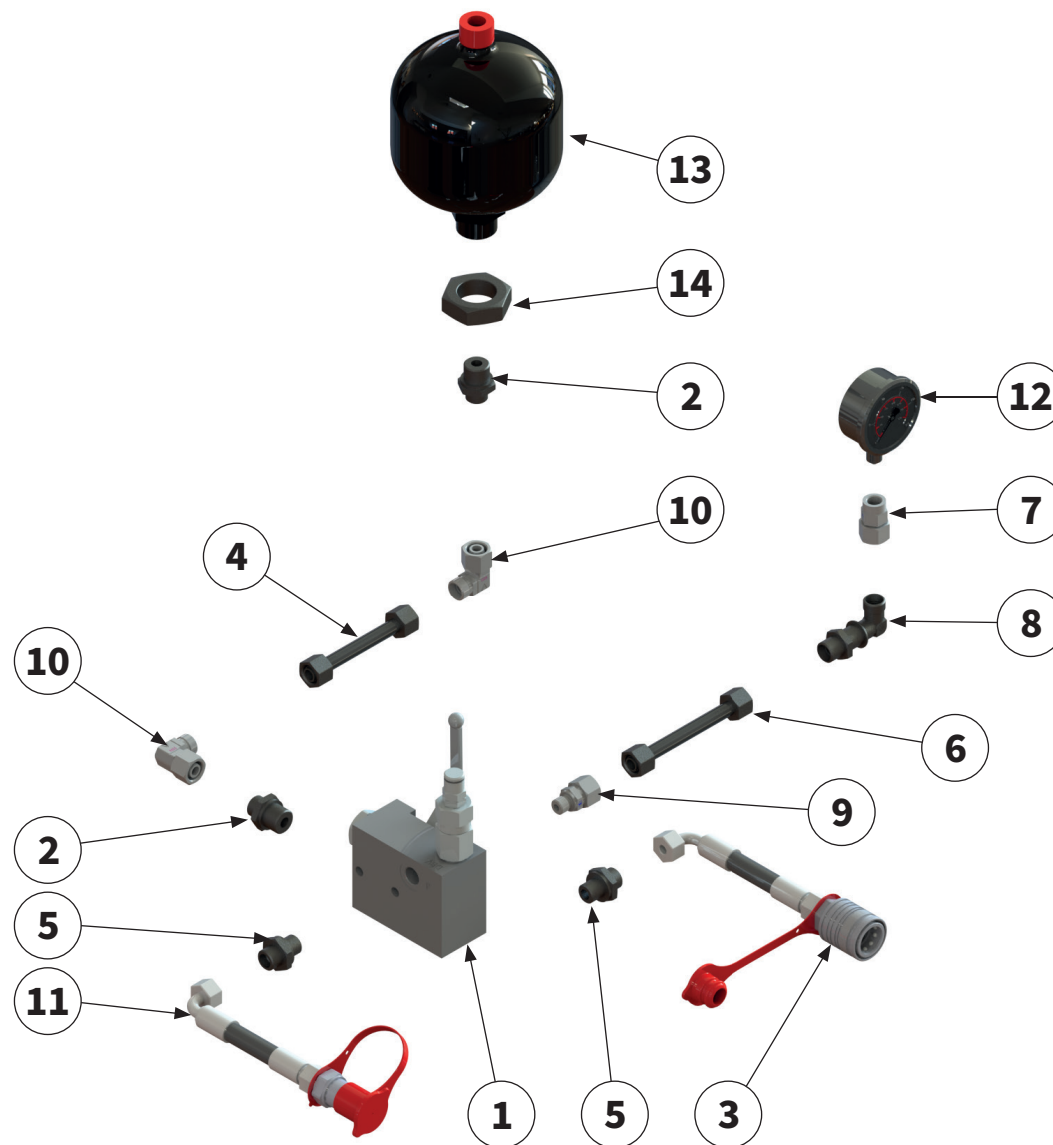

HYDRAULIKBAUGRUPPE MU-SOFA MOBIL |
 Hydraulic assembly MU-SOFA mobile |
 Assemblage hydraulique MU-SOFA mobil |
 Ensamble hidráulico MU-SOFA móvil |

Pos.-Nr. No. Número	Ersatzteilnummer Manufacturer part number Numéro d'article du fabricant Número de pieza del fabricante							DE Bezeichnung	EN Designation	FR Désignation	ES Designación	
	Anzahl quantity quantité número											
	MU-H 120	MU-H 140	MU-H 150	MU-H 160	MU-H 180	MU-H 200	MU-H 220					
1	1	1	1	00049325	1	1	1	1	Stromregelventil	flow control valve	Soupape de régulation de débit	Válvula reguladora de flujo
2	2	2	2	00044462	2	2	2	2	Verschraubung	Screwed connection	Raccord à vis	Atornillamiento
3	1	1	1	00048967	1	1	1	1	Hydraulikschlauch	hydraulic hose	Tuyau hydraulique	Tubo flexible hidráulico
4	1	1	1	00046413	1	1	1	1	Hydraulikrohr	hydraulic pipe	tuyau hydraulique	tubería hidráulica
5	2	2	2	00044463	2	2	2	2	Verschraubung	Screwed connection	Raccord à vis	Atornillamiento
6	1	1	1	00048966	1	1	1	1	Hydraulikrohr	hydraulic pipe	tuyau hydraulique	tubería hidráulica
7	1	1	1	00045073	1	1	1	1	Verschraubung	Screwed connection	Raccord à vis	Atornillamiento
8	1	1	1	00044420	1	1	1	1	Verschraubung	Screwed connection	Raccord à vis	Atornillamiento
9	1	1	1	00046373	1	1	1	1	Verschraubung	Screwed connection	Raccord à vis	Atornillamiento
10	2	2	2	00044448	2	2	2	2	Verschraubung	Screwed connection	Raccord à vis	Atornillamiento
11	1	1	1	00042403	1	1	1	1	Hydraulikschlauch	hydraulic hose	Tuyau hydraulique	Tubo flexible hidráulico
12	1	1	1	00013537	1	1	1	1	Manometer	Pressure gauge	Manomètre	Manómetro
13	1	1	1	00009702	1	1	1	1	Stickstoffblase	nitrogen accumulator	Poche d'azote	Burbuja de nitrógeno
14	1	1	1	00001159	1	1	1	1	Mutter	nut	Ecrou	Tuerca



Bei weiteren Fragen zu Technik und Einsatz Ihres
Gerätes stehen Ihnen unsere Mitarbeiter oder unsere
Vertriebspartner (siehe www.muething.com) gerne zur
Verfügung.

Our employees or sales partners (see www.muething.com)
are happy to help should you have any further questions on
the technical aspects and use of your implement.

Nos collaborateurs ou nos partenaires commerciaux
(voir www.muething.com) sont à votre entière disposition
pour toutes questions complémentaires relatives aux
caractéristiques techniques ou à l'utilisation de votre engin.

Tanto nuestros empleados como los socios comerciales de la
marca (ver www.muething.com) estamos a su disposición
para atender cualquier consulta técnica o sobre piezas que
pueda tener respecto a su equipo.

The logo for Muething, featuring the word "Muething" in a bold, black, sans-serif font. The letter "u" is stylized with a red semi-circle above it, resembling a drop or a gear tooth.

Muething GmbH & Co. KG Soest
Am Silberberg 23
59494 Soest

Tel +49 (0) 2921 96510
Fax +49 (0) 2921 73080

soest@muething.com

Muething GmbH & Co. KG Uffenheim
Am Brünlein 2
97215 Uffenheim

Tel +49 (0) 9842 98660
Fax +49 (0) 9842 98667

uffenheim@muething.com

WWW.MUETHING.COM